



HYDRAULIC HOSES 2026

T4000 RYCO SLIDER™ T4006S 3/8" -06 DN10

H6000 RYCO DIEHARD™ H6000

RYCO DRILLER

RYCO SHOCKWAVE SW16008 1/2" -08 DN10

RYCO ISOLATOR TWIN TP86TN 3/8 -06 DN10 MAX WP

RYCO BIOTRANS BT112 3/4" -12 DN19 MAX WP 50 BAR / 725 PSI

T3000 RYCO DIEHARD™ T3008D

H6000 RYCO SLIDER™ H6016S 1" -16 DN25 MAX WP

H5000 RYCO DIEHARD™ H5020D

T4000 RYCO SLIDER™ T4006S 3/8" -06 DN10 MAX WP 280 BAR / 4100 PSI MSHA ABRASION RESISTANT

RYCO DIEHARD™ T28D 1/2" -08 DN12 MAX WP 350 BAR

“At Ryco we design, manufacture, and supply premium quality and cutting-edge fluid transfer products, and solutions for a large range of industries around the world.”



Our experienced Research & Development team take 2D drawings to 3D models to real life products.



Our world-class hoses, fittings and assembly equipment are manufactured in-house to the highest standards.



We test and validate our products to meet and exceed technical industry standards.



We provide the complete solution: hoses, fittings, crimping parameters and assembly equipment for a fully integrated system.



We supply fluid conveyance solutions directly to our customers whenever and wherever they are.

Ryco Hydraulics started manufacturing hoses and fittings in 1946. As the hydraulics industry evolved, the company expanded its range, and the main product line soon became high-pressure hydraulic hose and fittings. Today, Ryco Hydraulics is known for its engineering excellence, customer-focus, and highest quality products which continue to attract new customers, from varied industries right across the world.

With a comprehensive range of hydraulic hoses, hydraulic couplings, industrial hoses, and assembly equipment, Ryco is a global leader in designing, manufacturing, and distributing fluid transfer solutions.

Ryco Hydraulics' products not only meet but exceed industry standards, ensuring maximum performance and reliability. From open-pit and underground mining, to construction, agriculture, marine, forestry and oil & gas industries, our hose assemblies are trusted by clients worldwide.

Whether it's our hoses, fittings, or assembly machines, at Ryco Hydraulics we do more than simply supply a product; we understand our success is dependent on our clients' success, safety, and quality.

With a global presence and a focus on local service, we are dedicated to empowering various industries with reliable, high-performance fluid products and systems tailored to our customer's unique needs.



INTRODUCTION

HOSES

TECHNICAL

Ryco manufactures high quality, abrasion resistant and accredited hydraulic hoses covering a broad range of international standards. Ryco hydraulic hoses provide unparalleled performance, safety, and longevity.

Ryco hoses are designed and engineered for maximum safety, leak-free performance and exceptional productivity and reliability.

We offer many different hose types and pressure ranges to suit a wide variety of applications.

No matter your pressure system's needs, Ryco has you covered.

GSX – GENERAL | SELECT | XTREME

In order to make hose selection easier, we categorize our hoses according to the GSX system, which is made up of three complementary hose categories, helping users identify which type of hose is most suitable for their requirements.

GENERAL HOSES

General hoses are designed to meet the requirements of international norms, offering high-quality and reliability in most standard hydraulic applications.

SELECT HOSES

Select hoses are designed to meet and exceed the requirements of international norms; these are high-performance products ideal for demanding applications.

XTREME HOSES

Xtreme hoses are a superior range of products designed for the highest level of performance in specific applications thanks to their advanced properties. These hoses are developed to be some of the most advanced products on the market today, allowing them to surpass expectations and requirements in specific environmental challenges.

INTRODUCTION

RYCO QUALITY ACCREDITATION

Ryco Hydraulics is committed to the objective of zero defects. As a manufacturer of quality hydraulic hose and fittings, Ryco Hydraulics ensures that our products are accredited by independent third party organisations.



ABS

American Bureau of Shipping



DNV-GL

DNV GL Group



LR

Lloyd's Register



MED

Marine Equipment Directive



USCG

US Coast Guard



DOT

Dept. of Transport (USA)



GOST-R

GOST-R



BUREAU VERITAS

Bureau Veritas



RINA

Registro Italiano Navale



KR

Korean Register



CLASSNK

Nippon Kaiji Kyokai



MDG 41

Mining Design Guide



SAFETY GUIDE: DON'T MIX & MATCH

Ryco hose and fitting products must be assembled in strict accordance with Ryco instructions and limitations. Don't mix and match: always use Ryco original hoses and fittings. Ryco hose, fittings, and assembling machines are tested as an effective and reliable system. The use of different products and machines will affect and nullify any representation and/or warranty on products, their features and/or performance that may have been provided, and may cause premature hose failures, property damage, serious injury or death for which Ryco does not assume any responsibility and/or liability at any title whatsoever. Inside our Digital Crimp Tools, you can find the only official technical crimping parameters relating to our products and/or services. Therefore, please be sure to use the latest version of our Crimp App and Web Tool.

RYCO MAKES NO REPRESENTATIONS AND/OR WARRANTIES, EXPRESS OR IMPLIED, AND ASSUMES NO RESPONSIBILITY AND/OR LIABILITY FOR ANY LOSS OR DAMAGE, WHETHER DIRECT, INDIRECT, CONSEQUENTIAL OR INCIDENTAL WHICH MIGHT ARISE OUT FROM, OR IN CONNECTION WITH, IMPROPER AND/OR INCORRECT USE OF ITS PRODUCTS AND/OR ASSEMBLY EQUIPMENT OR FROM ANY USE OF CRIMPED HOSE ASSEMBLIES NOT PRODUCED FROM GENUINE RYCO HOSE FITTINGS, HOSE AND EQUIPMENT, AND, IN GENERAL, NOT IN ACCORDANCE WITH OUR PROCESS SPECIFICATIONS FOR EACH SPECIFIC PRODUCT AND/OR ASSEMBLY EQUIPMENT.

DISCLAIMER

We reserve the right to modify our products and/or related services and/or discontinue the manufacture and/or supply of any of the products and/or related services, without notice. No product is warranted as being fit for a particular purpose and we do not assume any liability in connection with the use of our products other than those technically approved in writing by us, or specified in the relevant official technical specifications released by us, for specific products. This document supersedes all previous versions and previously issued documentation. The only official source of technical crimping parameters regarding our products is our Digital Crimp Tools. Printed copies are uncontrolled therefore, please be sure to use the latest versions of our [Ryco Crimp App](#) or visit our [Crimp Web Tool](#). For more information, please visit our dedicated 'Contact' page on the [Ryco's website](#).

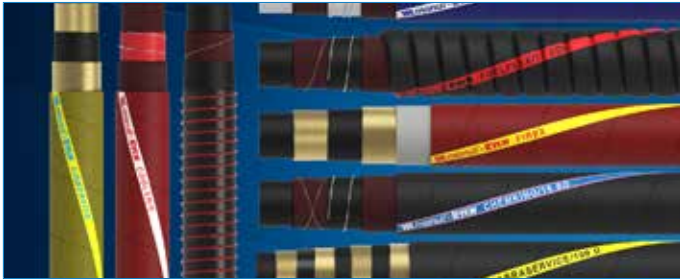

HOSES



TECHNICAL

INTRODUCTION

HOSES

TECHNICAL

PICTORIAL INDEX

ISOBARIC BRAID 1
 BRAID 2
 SPIRAL 4
 SPECIALTY & HIGH TEMPERATURE 4
 HIGH PRESSURE WATERBLAST 5
 PRESSURE WASHER 5
 SUCTION AND RETURN 6
 TEFLON® 6
 TEXTILE BRAID 6
 THERMOPLASTIC 6
 GREASING AND LUBRICATION 7
 HOSE SERIES 8
 HOSE PROTECTION 8

HOSE APPROVALS

HOSE TYPE APPROVALS 9
 HOSE COVERS 17

SPECIFICATIONS

SPECIFICATIONS SUMMARY 20

HOSE DATA SHEETS

ISOBARIC BRAID 24
 BRAID 46
 SPIRAL 67
 SPECIALTY AND HIGH TEMPERATURE 70
 VERY HIGH PRESSURE WATERBLAST 82
 PRESSURE WASHER 83
 SUCTION & RETURN 87
 TEFLON® 89
 TEXTILE BRAID 90
 THERMOPLASTIC 95
 GREASING AND LUBRICATION 104
 HOSE PROTECTION - FS1072 FIRE SLEEVE 107
 HOSE TRACKING - RHYT HOSE TAG 120
 HOW TO ORDER RYCO HYDRAULIC HOSE 121

TECHNICAL INFORMATION

TECHNICAL 122
 HOSE SIZE SELECTION NOMOGRAPH 123
 HOW TO ORDER HOSE ASSEMBLIES 124
 HOSE SELECTION 126
 SAFETY GUIDE 128
 SAFETY GUIDE - MAXIMUM TEMPERATURE LIMITS 131
 CHARACTERISTICS OF HOSE ELASTOMERS 133
 CHEMICAL COMPATIBILITY FOR HOSE 134
 FIELD ATTACHABLE NON-SKIVE HOSE ASSEMBLY 135
 NON-SKIVE HOSE ASSEMBLY 137
 SKIVE HOSE ASSEMBLY 138
 ASSEMBLY INSTRUCTIONS - RTH1 HOSES 139
 ASSEMBLY INSTRUCTIONS - SRX/HT & SRF/P HOSES 140
 PUSH-ON HOSE ASSEMBLY 141
 ASSEMBLY INSTRUCTIONS - TP7T, TP7TN, TP8T AND TP8TN TWIN HOSE 142
 TUBE FLARING DIMENSIONS - 37° JIC AND 45° SAE 143
 ASSEMBLY INSTRUCTIONS - TUBE BITE HOSE COUPLINGS (END STYLE 850) 145
 ASSEMBLY INSTRUCTIONS - S134 J-LOK FLARELESS TUBE FITTINGS 147
 HOSE ASSEMBLY - INSTALLATION GUIDE 149
 FACTOR OF SAFETY - HOSE ASSEMBLIES 152
 GUIDE TO THREAD AND CONNECTOR WORKING PRESSURES 153
 IMPORTANT NOTE REGARDING THREAD DASH SIZE/TUBE DASH SIZE 158
 THREAD AND CONNECTOR IDENTIFICATION 159
 TORQUE ASSEMBLY VALUES 172

ABBREVIATIONS

ABBREVIATIONS 174

INDEX

INDEX 175

HOSES

PICTORIAL INDEX



HOSE SERIES		INSIDE DIAMETER	RECOMMENDED	CONSTRUCTION	PERFORMANCE SPECIFICATIONS MET OR EXCEEDED	COUPLING SERIES
ISOBARIC BRAID						
24	T3000D DIEHARD™		-04 to -16 1/4" to 1"	High pressure hydraulic oil lines.	Oil resistant synthetic rubber tube. One or two braids of high tensile steel wire reinforcement. Oil and extra abrasion resistant synthetic rubber cover.	ISO 18752-BC SAE 100R17 T2000
25	T3000S SLIDER		-04 to -16 1/4" to 1"	High pressure hydraulic oil lines.	Oil resistant synthetic rubber tube. One or two braids of high tensile steel wire reinforcement. Synthetic rubber cover sheathed with a layer of extremely abrasion resistant polyethylene cover.	ISO 18752-BC SAE 100R17 T2000
26	T3600C ICEBREAKER		-04 to -16 1/4" to 1"	High pressure hydraulic oil lines in applications where low temperature environmental conditions exist.	Oil resistant synthetic rubber tube. One braid of high tensile steel wire reinforcement. Oil and extra abrasion resistant synthetic rubber cover.	ISO 18752-BC T2000
27	T3600D DIEHARD™		-04 to -16 1/4" to 1"	High pressure hydraulic oil lines.	Oil resistant synthetic rubber tube. One or two braids of high tensile steel wire reinforcement. Oil and extra abrasion resistant synthetic rubber cover.	ISO 18752-BC T2000
28	T3600S SLIDER		-04 to -16 1/4" to 1"	High pressure hydraulic oil lines.	Oil resistant synthetic rubber. One or two braids of high tensile steel wire reinforcement. Oil and abrasion resistant synthetic rubber sheathed with a layer of extremely abrasion resistant polyethylene cover.	ISO 18752-BC T2000
29	T4000D DIEHARD™		-04 to -12 1/4" to 3/4"	High pressure hydraulic oil lines.	Oil resistant synthetic rubber tube. One or two braids of high tensile steel wire reinforcement. Oil and extra abrasion resistant synthetic rubber cover.	ISO 18752-BC SAE 100R19 T2000
30	T4000S SLIDER		-04 to -12 1/4" to 3/4"	High pressure hydraulic oil lines.	Oil resistant synthetic rubber tube. One or two braids of high tensile steel wire reinforcement. Synthetic rubber cover sheathed with a layer of extremely abrasion resistant polyethylene.	ISO 18752-BC SAE 100R19 T2000
31	T5000D DIEHARD™		-04 to -08 1/4" to 1/2"	Very high pressure hydraulic oil lines.	Oil resistant synthetic rubber tube. Two braids of high tensile steel wire reinforcement. Oil and extra abrasion resistant synthetic rubber cover.	ISO 18752-BC T2000
32	T5000S SLIDER		-04 to -08 1/4" to 1/2"	Very high pressure hydraulic oil lines.	Oil resistant synthetic rubber tube. Two braids of high tensile steel wire reinforcement. Synthetic rubber cover sheathed with a layer of extremely abrasion resistant polyethylene.	ISO 18752-BC T2000
33	T6000D DIEHARD™		-04 to -06 1/4" to 3/8"	Extremely high pressure hydraulic oil lines.	Oil resistant synthetic rubber tube. Two braids of high tensile steel wire reinforcement. Oil and extra abrasion resistant synthetic rubber cover.	ISO 18752-BC T2000
34	T6000S SLIDER		-04 to -06 1/4" to 3/8"	Extremely high pressure hydraulic oil lines.	Oil resistant synthetic rubber tube. Two braids of high tensile steel wire reinforcement. Synthetic rubber cover sheathed with a layer of extremely abrasion resistant polyethylene.	ISO 18752-BC T2000
ISOBARIC SPIRAL						
35	H3000D DIEHARD™		-20 to -32 1.1/4" to 2"	High pressure hydraulic oil lines.	Oil resistant synthetic rubber tube. Four alternating layers of spiralled high tensile steel wire reinforcement. Oil and extra abrasion resistant synthetic rubber cover.	EN 856 Type R12 EN 856 Type 4SP ISO 18752-DC SAE 100R12 T7000
36	H3000S SLIDER		-20 to -32 1.1/4" to 2"	High pressure hydraulic oil lines.	Oil resistant synthetic rubber tube. Four alternating layers of spiralled high tensile steel wire reinforcement. Synthetic rubber cover sheathed with a layer of extremely abrasion resistant polyethylene.	EN 856 Type R12 EN 856 Type 4SP ISO 18752-DC SAE 100R12 T7000

HOSE SERIES	INSIDE DIAMETER	RECOMMENDED	CONSTRUCTION	PERFORMANCE SPECIFICATIONS MET OR EXCEEDED	COUPLING SERIES
-------------	-----------------	-------------	--------------	--	-----------------

ISOBARIC SPIRAL (CONT)

37	H4000D DIEHARD™		-06 to -32 3/8" to 2"	High pressure hydraulic oil lines.	Oil resistant synthetic rubber tube. Four or six alternating layers of spiralled high tensile steel wire reinforcement. Oil and extra abrasion resistant synthetic rubber cover.	EN 856 Type R12 EN 856 Type 45P (size DN25, -16) ISO 18752-DC SAE 100R12	T7000
38	H4000S SLIDER		-06 to -32 3/8" to 2"	High pressure hydraulic oil lines.	Oil resistant synthetic rubber tube. Four or six alternating layers of spiralled high tensile steel wire reinforcement. Synthetic rubber cover sheathed with a layer of extremely abrasion resistant polyethylene.	EN 856 Type R12 EN 856 Type 45P (size DN25, -16) ISO 18752-DC SAE 100R12	T7000
39	H5000C ICEBREAKER		-12 to -20 3/4" to 1 1/4"	Very high pressure hydraulic oil lines in applications where low temperature environmental conditions exist.	Very high pressure hydraulic oil lines in applications where low temperature environmental conditions exist. Small bend radius is an advantage in installations.	EN 856 Type R13 ISO 18752-CC SAE100R13	T7000
40	H5000D DIEHARD™		-06 to -32 3/8" to 2"	Very high pressure hydraulic oil lines.	Oil resistant synthetic rubber tube. Four or six alternating layers of spiralled high tensile steel wire reinforcement. Oil and extra abrasion resistant synthetic rubber cover.	EN 856 Type R13 ISO 18752-CC SAE100R13	T6000 T7000
41	H5000S SLIDER		-06 to -32 3/8" to 2"	Very high pressure hydraulic oil lines.	Oil resistant synthetic rubber tube. Four or six alternating layers of spiralled high tensile steel wire reinforcement. Synthetic rubber cover sheathed with a layer of extremely abrasion resistant polyethylene.	EN 856 Type R13 ISO 18752-CC SAE 100R13	T6000 T7000
42	H6000D DIEHARD™		-06 to -32 3/8" to 2"	Extremely high pressure hydraulic oil lines.	Oil resistant synthetic rubber tube. Four, six or eight alternating layers of spiralled high tensile steel wire reinforcement. Oil and extra abrasion resistant synthetic rubber cover.	EN 856 Type R15 ISO 18752-CC SAE 100R15	T6000 T7000
43	H6000S SLIDER		-06 to -32 3/8" to 2"	Extremely high pressure hydraulic oil lines.	Oil resistant synthetic rubber tube. Four, six or eight alternating layers of spiralled high tensile steel wire reinforcement. Synthetic rubber cover sheathed with a layer of extremely abrasion resistant polyethylene.	ISO 3862 Type R15 ISO 18752-CC SAE 100R15	T6000 T7000
44	C6000D DIEHARD™		-12 to -16 3/4" to 1"	Ultra flexible, extremely high pressure hydraulic oil lines.	Oil resistant synthetic rubber tube. Four alternating layers of spiralled high tensile steel wire reinforcement. Oil and extra abrasion resistant synthetic rubber cover.	ISO 18752-CC SAE100R15	T7000
45	C6000S SLIDER		-12 to -16 3/4" to 1"	Ultra flexible, extremely high pressure hydraulic oil lines.	Synthetic rubber cover sheathed with a layer of extremely abrasion resistant polyethylene. Oil and extra abrasion resistant synthetic rubber cover.	ISO 18752-CC SAE100R15	T7000

BRAID

46	DF1D DIEHARD™		-04 to -16 1/4 to 1"	High pressure hydraulic oil lines.	Oil resistant synthetic rubber tube. One braid of high tensile steel wire reinforcement. Oil and extra abrasion resistant synthetic rubber cover.	EN 857 Type 15C ISO 11237 Type 15C	T2000
47	DF2D DIEHARD™		-04 to -20 1/4 to 1.1/4"	High pressure hydraulic oil lines.	Oil resistant synthetic rubber tube. Two braids of high tensile steel wire reinforcement. Oil and extra abrasion resistant synthetic rubber cover.	EN 857 Type 25C ISO 11237 Type 25C SAE 100R16	T2000
48	DK1D DIEHARD™		-04 to -20 1/4 to 1.1/4"	Extra abrasion resistant high pressure hydraulic oil lines.	Oil resistant synthetic rubber tube. One braid of high tensile steel wire reinforcement. Oil and extra abrasion resistant synthetic rubber cover.	EN 857 Type 15C ISO 11237 Type 15C	T2000
49	DK1E ENERGY		-04 to -16 1/4" to 1"	High pressure hydraulic oil lines.	Oil resistant synthetic rubber tube. One braid of high tensile steel wire reinforcement. Oil resistant synthetic rubber cover.	EN 857 Type 15C ISO 11237 Type 15C	T2000





HOSES

PICTORIAL INDEX



HOSE SERIES		INSIDE DIAMETER	RECOMMENDED	CONSTRUCTION	PERFORMANCE SPECIFICATIONS MET OR EXCEEDED	COUPLING SERIES
BRAID (CONT)						
50	DK1S SLIDER		-04 to -20 1/4 to 1.1/4"	Extra abrasion resistant high pressure hydraulic oil lines.	Synthetic rubber cover sheathed with a layer of extremely abrasion resistant polyethylene. Oil and extra abrasion resistant synthetic rubber cover.	EN 857 Type 1SC ISO 11237 Type 1SC T2000
51	DK2D DIEHARD™		-04 to -20 1/4 to 1.1/4"	Extra abrasion resistant high pressure hydraulic oil lines.	Oil resistant synthetic rubber tube. Two braids of high tensile steel wire reinforcement. Oil and extra abrasion resistant synthetic rubber cover.	EN 857 Type 2SC ISO 6805 Type 1 & Type 2 ISO 6805 Type 4 T2000
52	DK2E ENERGY		-04 to -16 1/4" to 1"	High pressure hydraulic oil lines.	Oil resistant synthetic rubber tube. Two braids of high tensile steel wire reinforcement. Oil resistant synthetic rubber cover.	EN 857 Type 2SC ISO 6805 Type 1 & Type 2 ISO 6805 Type 4 T2000
53	DK2S SLIDER		-04 to -16 1/4" to 1"	High pressure hydraulic oil lines.	Synthetic rubber cover sheathed with a layer of extremely abrasion resistant polyethylene. Oil and extra abrasion resistant synthetic rubber cover.	EN 857 Type 2SC ISO 6805 Type 1 & Type 2 ISO 6805 Type 4 T2000
55	EC1 ENERGY		-04 to -16 1/4" to 1"	High pressure hydraulic oil lines. Compact outside diameter and smaller bend radius.	Oil resistant synthetic rubber tube. One braid of high tensile steel wire reinforcement. Oil resistant synthetic rubber cover.	EN 857 Type 1SC ISO 11237 Type 1SC T2000
56	EC2 ENERGY		-04 to -16 1/4" to 1"	High pressure hydraulic oil lines. Compact outside diameter and smaller bend radius.	Oil resistant synthetic rubber tube. Two braids of high tensile steel wire reinforcement. Oil resistant synthetic rubber cover.	EN 857 Type 2SC ISO 11237 Type 2SC SAE 100R16 T2000
57	ECP1 ENERGY		-03 to -08 3/16" to 1/2"	High pressure hydraulic oil pilot lines. Compact outside diameter and smaller bend radius.	Oil resistant synthetic rubber tube. One braid of high tensile steel wire reinforcement. Oil resistant synthetic rubber cover.	T2000
58	E1 ENERGY		-04 to -16 1/4" to 1"	High pressure hydraulic oil lines.	Oil resistant synthetic rubber tube. One braid of high tensile steel wire reinforcement. Oil resistant synthetic rubber cover.	AS 3791 100R1AT DIN 20022-1SN EN 853 Type 1SN ISO 1436 Types R1AT & 1SN SAE 100R1AT T2000 6000 (K000)
59	E2 ENERGY		-04 to -16 1/4" to 1"	High pressure hydraulic oil lines.	Oil resistant synthetic rubber tube. Two braids of high tensile steel wire reinforcement. Oil resistant synthetic rubber cover.	AS 3791 100R2AT DIN 20022 - 2SN EN 853 Type 2SN ISO 1436 Types R2AT & 2SN SAE 100R2AT T2000 T7000 6000 (L000)
60	T1D DIEHARD™		-03 to -32 3/16" to 2"	High pressure hydraulic oil lines.	Oil resistant synthetic rubber tube. One braid of high tensile steel wire reinforcement. Oil and extra abrasion resistant synthetic rubber cover.	AS 3791 100R1AT DIN 20022-1SN EN 853 Type 1SN ISO 1436 Types R1AT & 1SN SAE 100R1AT T2000 6000 (K000)
61	T1S SLIDER		-03 to -32 3/16" to 2"	High pressure hydraulic oil lines.	Oil resistant synthetic rubber tube. One braid of high tensile steel wire reinforcement. Synthetic rubber cover sheathed with a layer of extremely abrasion resistant polyethylene.	AS 3791 100R1AT DIN 20022-1SN EN 853 Type 1SN ISO 1436 Types R1AT & 1SN SAE 100R1AT T2000
62	T1F FIRE SUPPRESSION		-03 to -16 3/16" to 1"	Fire Suppression Systems of off-road vehicles, mining equipment, stationary engines, etc.	Oil resistant synthetic rubber tube. One braid of high tensile steel wire reinforcement. Red, heat resistant, abrasion resistant and oil resistant rubber cover.	AS 3791 100R1AT DIN 20022-1SN EN 853 Type 1SN ISO 1436 Types R1AT & 1SN SAE 100R1AT T2000 6000 (K000)

HOSE SERIES		INSIDE DIAMETER	RECOMMENDED	CONSTRUCTION	PERFORMANCE SPECIFICATIONS MET OR EXCEEDED	COUPLING SERIES
-------------	--	-----------------	-------------	--------------	--	-----------------



BRAID (CONT)

63	T2D DIEHARD™		-04 to -48 1/4" to 3"	High pressure hydraulic oil lines.	Oil resistant synthetic rubber tube. Two braids of high tensile steel wire reinforcement. Oil and extra abrasion resistant synthetic rubber cover.	AS 3791 100R2AT DIN 20022 - 2SN EN 853 Type 2SN ISO 1436 Types R2AT & 2SN SAE 100R2AT	T2000 T7000 6000 (L000)
64	T2S SLIDER		-04 to -32 1/4" to 2"	High pressure hydraulic oil lines.	Oil resistant synthetic rubber tube. Two braids of high tensile steel wire reinforcement. Synthetic rubber cover sheathed with a layer of extremely abrasion resistant polyethylene.	AS 3791 100R2AT DIN 20022-2SN EN 853 Type 2SN ISO 1436 Types R2AT & 2SN SAE 100R2AT	T2000 T7000
65	T2C ICEBREAKER		-04 to -32 1/4" to 2"	High pressure hydraulic oil lines in applications where low temperature environmental conditions exist.	Specially formulated oil resistant synthetic rubber tube. Two braids of high tensile steel wire reinforcement. Oil resistant and abrasion resistant synthetic rubber cover.	AS 3791 100R2AT DIN 20022-2SN EN 853 Type 2SN ISO 1436 Types R2AT & 2SN SAE 100R2AT	T2000
66	TXA2D DIEHARD™		-08 to -16 1/2" to 1"	Extra high pressure hydraulic oil lines where pressure exceeds 100R2 by at least 30%.	Oil resistant synthetic rubber tube. Two braids of high tensile steel wire reinforcement. Oil and extra abrasion resistant synthetic rubber cover.	AS 3791 100R2AT BCS 174 DIN 20022-2SN EN 853 Type 2SN ISO 1436 Types R2AT & 2SN SAE 100R2AT	T2000 T7000 6000 (L000)

SPIRAL

67	H12D DIEHARD™		-06 to -40 3/8" to 2.1/2"	Very high pressure hydraulic oil lines.	Oil resistant synthetic rubber tube. Four alternating layers of spiralled high tensile steel wire reinforcement. Oil and extra abrasion resistant synthetic rubber cover.	AS 3791 100R12 EN 856 Type R12 EN 856 Type 4SP (-12 and above) ISO 3862 Type R12 SAE 100R12	T7000
68	H12S SLIDER		-06 to -32 3/8" to 3"	Very high pressure hydraulic oil lines.	Oil resistant synthetic rubber tube. Four alternating layers of spiralled high tensile steel wire reinforcement. Synthetic rubber cover sheathed with a layer of extremely abrasion resistant polyethylene.	AS 3791 100R12 EN 856 Type R12 EN 856 Type 4SP (-12 and above) ISO 3862 Type R12 SAE 100R12	T7000

SPECIALTY & HIGH TEMPERATURE

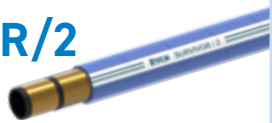
70	TJ2D DIEHARD™ JACK		-04 to -06 1/4" & 3/8"	Hydraulic Jack applications requiring a light weight, small outside diameter hose.	Oil resistant synthetic rubber tube. Two braids of high tensile steel wire reinforcement. Oil and extra abrasion resistant synthetic rubber cover.	Materials Handling Institute specification IJ 100 (July 1979)	T2000
72	D4000D DRIFTER		-08 to -16 1/2" to 1"	High pressure hydraulic oil lines and Jumbo drill rig drifter (rock drill) units.	Black, oil and extra abrasion resistant synthetic rubber. Flame Resistant, Anti-Static (FRAS) & MSHA compliant.	AS 2660 and Methods of Test AS 1180.10B and 13A	T7000
73	SURVIVOR/1 SURVIVOR™		-04 to -16 1/4" to 1"	High pressure hydraulic oil applications.	Synthetic rubber tube, compounded for temperature resistance and multi fluid resistance. One braid of high tensile steel wire reinforcement. Oil resistant and abrasion resistant synthetic rubber cover.	AS 3791 100R1AT DIN 20022-1SN EN 853 Type 1SN ISO 1436 Types R1AT & 1SN SAE 100R1AT	T2000 6000 (K000)
74	SURVIVOR/2 SURVIVOR™		-04 to -32 1/4" to 2"	High pressure hydraulic oil applications.	Synthetic rubber tube. Two braids of high tensile steel wire reinforcement. Oil resistant and abrasion resistant synthetic rubber cover.	AS 3791 100R2AT DIN 20022-2SN EN 853 Type 2SN ISO 1436 Types R2AT & 2SN SAE 100R2AT	T2000 T7000 6000 (L000)
75	SURVIVOR/R5 SURVIVOR™		-04 to -32 1/4" to 2"	Medium to high pressure hydraulic oil applications.	Oil resistant synthetic rubber tube. Polyester inner braid covered with one braid of high tensile steel wire reinforcement. Polyester braid cover.	AS 3791 100R5 SAE 100R5 SAE J1402 Type All (up to -12 size)	T4000 V000
76	D2B DRILLER		-20 to -32 1.1/4" to 2"	Hydraulic oil or air lines. Drill rigs - high pressure, large bore air hose.	Oil resistant synthetic rubber tube. Two braids of high tensile steel wire reinforcement. Oil and abrasion resistant synthetic rubber cover.		T2000 T7000

HOSES





PICTORIAL INDEX

HOSE SERIES		INSIDE DIAMETER	RECOMMENDED	CONSTRUCTION	PERFORMANCE SPECIFICATIONS MET OR EXCEEDED	COUPLING SERIES	
SPECIALTY & HIGH TEMPERATURE (CONT)							
77	T5 TRUCKER		-04 to -32 1/4" to 2"	Medium to high pressure hydraulic oil applications.	Oil resistant synthetic rubber tube. Polyester inner braid covered with one braid of high tensile steel wire reinforcement. Polyester braid cover.	AS 3791 100R5 SAE 100R5 SAE J1402 Type All (up to -12 size)	T4000 V000
78	MS1000 MINESPRAY		-08 to -32 1/2" to 2"	Water and air spray suited for dust control in all industrial and mining applications.	Oil resistant synthetic rubber tube. One braid of high tensile steel wire reinforcement. Oil resistant and abrasion resistant synthetic rubber cover.		T2000
79	CS1000 COALSPRAY		-08 to -32 1/2" to 2"	Water and air spray suited for dust control in all industrial and mining applications.	Oil resistant synthetic rubber tube. One braid of high tensile steel wire reinforcement. Oil resistant and abrasion resistant synthetic rubber cover.		T2000
81	BT1 BIOTRANS		-04 to -16 1/4" to 1"	Transportation, marine fuel and engine hose applications.	Oil resistant synthetic rubber tube. One braid of high tensile steel wire reinforcement.	SAE J1527 Type Class I SAE J30R2 (non-marine) USCG SAE J1942	T2000 6000 (K000)
HIGH PRESSURE WATERBLAST							
82	SW SHOCKWAVE		-06 to -16 3/8" to 1"	Cleaning and preparation of marine surfaces, runway and swimming pool cleaning, and paint removal.	Oil and water resistant synthetic rubber tube. Four high tensile steel spirals reinforcement. Oil, water and ozone resistant synthetic rubber cover.	AS/NZS 4233.2 EN 1829-2 ISO 7751	TW4000
PRESSURE WASHER							
83	JS4000 JS4000G JETSTORM		-04 to -08 1/4" to 1/2"	Cleaning and preparation of marine surfaces, runway and swimming pool cleaning, and paint removal. JS4000G is Animal Fat Resistant (AFR).	Oil and water resistant synthetic rubber tube. One braid of high tensile steel spiral reinforcement. Oil, water and ozone resistant synthetic rubber cover.	EN 1829-2	T2000
84	JS4000BX JS4000GX JETSTORM		-04 to -08 1/4" to 1/2"	Cleaning and preparation of marine surfaces, runway and swimming pool cleaning, and paint removal.	Oil and water resistant synthetic rubber tube. One braid of high tensile steel spiral reinforcement. Oil, water and ozone resistant synthetic rubber cover.	EN 1829-2	T2000
85	JS6000 JS6000G JETSTORM		-04 to -08 1/4" to 1/2"	Cleaning & preparation of marine surfaces, runway and swimming pool cleaning, and paint removal. JS6000G is Animal Fat Resistant (AFR).	Oil and water resistant synthetic rubber tube. Two braids of high tensile steel spiral reinforcement. Oil, water and ozone resistant synthetic rubber cover.	EN 1829-2	T2000
86	JS6000BX JS6000GX JETSTORM		-04 to -08 1/4" to 1/2"	Cleaning and preparation of marine surfaces, runway and swimming pool cleaning, and paint removal.	Oil and water resistant synthetic rubber tube. Two braids of high tensile steel spiral reinforcement. Oil, water and ozone resistant synthetic rubber cover.	EN 1829-2	T2000
SUCTION AND RETURN							
87	SRF/P COMPACT SUCTION		-12 to -64 3/4" to 4"	Petroleum and water base hydraulic fluids in suction lines or in low pressure return lines.	Oil resistant synthetic rubber tube. Textile reinforcement with spiral wire to prevent collapsing. Oil resistant and abrasion resistant synthetic rubber cover.	AS 3791 100R4 SAE 100R4	33000 T4000
88	SRX/HT COMPACT SUCTION		-12 to -64 3/4" to 4"	Petroleum and water base hydraulic fluids in suction lines or in low pressure return lines where extreme flexibility is required.	Oil resistant synthetic rubber tube. Textile reinforcement with spiral wire to prevent collapsing. Oil resistant and abrasion resistant synthetic rubber cover. Extremely flexible.	AS 3791 100R4 SAE 100R4	33000 T4000

HOSE SERIES		INSIDE DIAMETER	RECOMMENDED	CONSTRUCTION	PERFORMANCE SPECIFICATIONS MET OR EXCEEDED	COUPLING SERIES	
TEFLON®							
89	RTH1 TEFLON®		-04 to -16 1/4" to 1"	High pressure hydraulic oils. Fluids at extremes of pressure and temperature.	PTFE tube (TEFLON®). One braid of high tensile Grade 304 stainless steel wire reinforcement. *DuPont Reg. TM	SAE 100R14. RTH112 meets ID and OD requirements of SAE 100R14. Other sizes have ID and OD different to SAE 100R14	TT000
TEXTILE BRAID							
90	PL1D DIEHARD™		-04 to -12 1/4" to 3/4"	Petroleum base hydraulic oils, glycol antifreeze solutions, water, diesel fuels, and air.	Oil resistant synthetic rubber tube. One textile braid reinforcement. Oil and abrasion resistant synthetic rubber cover.	AS 3791 100R6 DIN 20021-1TE ISO 4079 Type R6 SAE 100R6	T4000 8000
91	PL1PV PUSH ON		-04 to -12 1/4" to 3/4"	Petroleum base hydraulic oils, glycol antifreeze solutions, water, diesel fuels, and air.	Oil resistant synthetic rubber tube. One textile braid reinforcement. Oil and abrasion resistant synthetic rubber cover	AS 3791 100R6 ISO 4079 Type 1 SAE 100R6	T4000 8000
92	MP1 MULTI-PURPOSE		-04 to -20 1/4" to 1.1/4"	Air, water, petroleum oils, kerosene and fuel oils.	Oil resistant synthetic rubber tube. One textile braid reinforcement. Oil resistant and abrasion resistant synthetic rubber cover.	RMA Class A (tube) RMA Class B (cover)	T4000
THERMOPLASTIC							
95	TP7 SPIDERLINE R7		-03 to -16 3/16" to 1"	High pressure hydraulic oil lines; pilot lines; greasing and lubrication lines; and some pneumatic and water lines.	Oil resistant seamless thermoplastic tube. One or two braids of synthetic fibre reinforcement. Oil and abrasion resistant thermoplastic perforated cover.	AS 3791 100R7 EN 855 TYPE R7 ISO 3949 TYPE R7 SAE 100R7	TP000
96	TP7N ISOLATOR R7		-04 to -16 1/4" to 1"	Hydraulic oil lines where electrical non-conductivity is required.	Oil resistant seamless thermoplastic tube. One or two braids of synthetic fibre reinforcement. Oil and abrasion resistant thermoplastic cover.	AS 3791 100R7 EN 855 TYPE R7 ISO 3949 TYPE R7 SAE 100R7	TP000
97	TP7T SPIDERLINE TWIN R7		-04 to -08 1/4" to 1/2"	Payout and return reels on forklifts and cranes, dispensing equipment and other applications requiring two hoses.	Oil resistant seamless thermoplastic tube. One or two braids of synthetic fibre reinforcement. Oil and abrasion resistant thermoplastic perforated cover.	AS 3791 100R7 EN 855 TYPE R7 ISO 3949 TYPE R7 SAE 100R7	TP000
98	TP7TN ISOLATOR TWIN R7		-04 to -08 1/4" to 1/2"	Payout and return reels on forklifts and cranes, hydraulic powered hand tools and other applications requiring two hoses.	Oil resistant seamless thermoplastic tube. One or two braids of synthetic fibre reinforcement. Oil and abrasion resistant thermoplastic cover.	AS 3791 100R7 EN 855 TYPE R7 ISO 3949 TYPE R7 SAE 100R7	TP000
99	TP8 SPIDERLINE R8		-04 to -08 1/4" to 1/2"	High pressure hydraulic oil lines; pilot lines; greasing and lubrication lines; and some pneumatic and water lines.	Oil resistant seamless thermoplastic tube. One or two braids of aramid fibre reinforcement. Oil and abrasion resistant thermoplastic perforated cover.	AS 3791 100R8 EN 855 TYPE R8 ISO 3949 TYPE R8 SAE 100R8	TP000
100	TP8N ISOLATOR R8		-04 to -08 1/4" to 1/2"	Hydraulic oil lines where electrical non-conductivity is required.	Oil resistant seamless thermoplastic tube. One or two braids of aramid fibre reinforcement. Oil and abrasion resistant thermoplastic cover.	AS 3791 100R8 EN 855 TYPE R8 ISO 3949 TYPE R8 SAE 100R8	TP000
101	TP8T SPIDERLINE TWIN R8		-04 to -08 1/4" to 1/2"	Payout and return reels on forklifts and cranes, dispensing equipment and other applications requiring two hoses.	Oil resistant seamless thermoplastic tube. One or two braids of aramid fibre reinforcement. Oil and abrasion resistant thermoplastic perforated cover.	AS 3791 100R8 EN 855 TYPE R8 ISO 3949 TYPE R8 SAE 100R8	TP000

HOSES

PICTORIAL INDEX

HOSE SERIES		INSIDE DIAMETER	RECOMMENDED	CONSTRUCTION	PERFORMANCE SPECIFICATIONS MET OR EXCEEDED	COUPLING SERIES
THERMOPLASTIC (CONT)						
102	TP8TN ISOLATOR TWIN R8		-04 to -08 1/4" to 1/2"	Payout and return reels on forklifts and cranes, hydraulic powered hand tools and other applications requiring two hoses.	Oil resistant seamless thermoplastic tube. One or two braids of aramid fibre reinforcement. Oil and abrasion resistant thermoplastic cover.	AS 3791 100R8 EN 855 Type R8 ISO 3949 TYPE R8 SAE 100R8 TP000
103	TP3000 SPIDERLINE R18		-04 to -08 1/4" to 1/2"	Medium pressure hose suitable for petroleum or synthetic based hydraulic fluids in forklift systems.	Polyester elastomer tube. One or two braids of synthetic fibre reinforcement. Special polyester, black with white ink-jet branding. Cover is perforated (pin-pricked).	SAE 100 R18 TP000
GREASING AND LUBRICATION						
104	TPGL GREASE LINE		-02 1/8"	High pressure greasing and lubrication systems.	Oil resistant seamless thermoplastic tube. One or two braids of synthetic fibre reinforcement. Oil and abrasion resistant thermoplastic perforated cover.	TG000 6000 (P000)
105	R4100N		-03 3/16"	Flexible Grease Gun extension for high pressure greasing and lubrication systems.	Oil resistant synthetic rubber tube. One braid of high tensile steel wire reinforcement. Oil and abrasion resistant synthetic rubber cover.	

HOSE SERIES		INSIDE DIAMETER	RECOMMENDED	CONSTRUCTION	PERFORMANCE SPECIFICATIONS MET OR EXCEEDED
HOSE PROTECTION					
107	FS FIRE SLEEVE 	-08 to -104 1/2" to 6.1/2"	Protection of hoses from heat and molten metal splashes.	Braided glass fibre tubing coated with silicon rubber.	SAE Aerospace Standard AS 1072
110	RCS CROCSLEEVE 	23 to 129 mm 7/8" to 5"	Burst and pinhole protection. Protection of hoses from abrasion. Bundling hoses together.	Woven polyamide. RCSB - Black. RCSR - Red.	MSHA approved FRAS
113	RH RAWHIDE 	23 to 93 mm 7/8" to 3.5/8"	Protection of hoses from severe abrasion. Bundling hoses together.	Woven nylon tubing.	MSHA approved
114	RSG SPIRAL GUARD 	16 to 110 mm (OD) 5/8" to 4.1/2"	Protection of hoses from abrasion and impact. Bundling hoses together.	Polyethylene plastic spiral. Black.	
114	RSGF SPIRAL GUARD FRAS 	16 to 110 mm (OD) 5/8" to 4.1/2"	Protection of hoses from abrasion and impact. Bundling hoses together.	Polyethylene plastic spiral. Dark Grey.	MSHA approved FRAS
114	RSGY SPIRAL GUARD 	16 to 110 mm (OD) 5/8" to 4.1/2"	Protection of hoses from abrasion and impact. Bundling hoses together.	Polyethylene plastic spiral. Yellow	
116	RWA PUSH ON 	12 to 75 mm 1/2" to 3"	Protection of hose cover from abrasion and gouges.	Spring Steel Wire, galvanised.	
118	RHYS PACKAGING SLEEVE 	48 & 79 mm 1.9" and 3.1"	Packaging and protection of hose assemblies during transport and storage.	Heavy duty, low density polyethylene sleeve.	
119	750/760 SPRING GUARD 	Suits some -04 (1/4") & -06 (3/8") hoses	Control bend radius at end of hose assemblies.	Spring Steel Wire, galvanised.	
120	RHYT RHYT-10, -32 	Suits sizes -04 to -10 & -12 to -32	Permanent identification of hose assemblies.	High performance plastic.	
120	RHWT RHWT-10, -32 	Suits sizes -04 to -10 & -12 to -32	Permanent identification of hose assemblies.	High performance plastic.	

HOSES

HOSE TYPE APPROVALS

The tables following on pages 44 to 48 list the approvals Ryco Hydraulics hold with various third parties for hoses used in Ryco Matched Hose Assemblies. For each Certification Body/Organisation referenced in the table, listed is; the Matched Ryco Coupling Series approved for the hoses listed.

EXAMPLE:

A Hose Assembly using **T3600D** needs to meet **Marine Equipment Directive (MED)** approval; the table shows: The **Matched Couplings** approved for use with **T3600D** hose: **T2000** Series Crimp Couplings. Refer to **the latest Ryco Digital Crimp Tools** for crimping parameters.

RYCO HOSE TYPE APPROVALS																
HOSE SERIES	DIEHARD	SLIDER	SURVIVOR	ENERGY	ICEBREAKER	ABS	DNV-GL	LR	MED	USCG	CLASSNK	GOST-R	BV	RINA	KR	MA-KA
T3000	D	S	S ^v	E	I											
T3004	•					T2000	T2000	T2000	T2000	T2000	T2000	T2000	T2000	T2000	T2000	T2000
T3005	•					T2000	T2000	T2000	T2000	T2000	T2000	T2000	T2000	T2000	T2000	T2000
T3006	•					T2000	T2000	T2000	T2000	T2000	T2000	T2000	T2000	T2000	T2000	T2000
T3008	•					T2000	T2000	T2000	T2000	T2000	T2000	T2000	T2000	T2000	T2000	T2000
T3010	•					T2000	T2000	T2000	T2000	T2000	T2000	T2000	T2000	T2000	T2000	T2000
T3012	•					T2000	T2000	T2000	T2000	T2000	T2000	T2000	T2000	T2000	T2000	T2000
T3016	•					T2000	T2000	T2000	T2000	T2000	T2000	T2000	T2000	T2000	T2000	T2000
T3600	D	S	S ^v	E	I											
T3604	•	•			•	T2000	T2000	T2000	T2000	T2000		T2000	T2000	T2000	T2000	T2000
T3605	•	•			•	T2000	T2000	T2000	T2000	T2000		T2000	T2000	T2000	T2000	T2000
T3606	•	•			•	T2000	T2000	T2000	T2000	T2000		T2000	T2000	T2000	T2000	T2000
T3608	•	•			•	T2000	T2000	T2000	T2000	T2000		T2000	T2000	T2000	T2000	T2000
T3610	•	•			•	T2000	T2000	T2000	T2000	T2000		T2000	T2000	T2000	T2000	T2000
T3612	•	•			•	T2000	T2000	T2000	T2000	T2000		T2000	T2000	T2000	T2000	T2000
T3616	•	•			•	T2000	T2000	T2000	T2000	T2000		T2000	T2000	T2000	T2000	T2000
T4000	D	S	S ^v	E	I											
T4004	•	•				T2000	T2000	T2000	T2000	T2000		T2000	T2000	T2000	T2000	T2000
T4005	•	•				T2000	T2000	T2000	T2000	T2000		T2000	T2000	T2000	T2000	T2000
T4006	•	•				T2000	T2000	T2000	T2000	T2000		T2000	T2000	T2000	T2000	T2000
T4008	•	•				T2000	T2000	T2000	T2000	T2000		T2000	T2000	T2000	T2000	T2000
T4010	•	•				T2000	T2000	T2000	T2000	T2000		T2000	T2000	T2000	T2000	T2000
T4012	•	•				T2000	T2000	T2000	T2000	T2000		T2000	T2000	T2000	T2000	T2000
T5000	D	S	S ^v	E	I											
T5004	•	•				T2000	T2000	T2000	T2000	T2000		T2000	T2000	T2000	T2000	T2000
T5005	•	•				T2000	T2000	T2000	T2000	T2000		T2000	T2000	T2000	T2000	T2000
T5006	•	•				T2000	T2000	T2000	T2000	T2000		T2000	T2000	T2000	T2000	T2000
T5008	•	•				T2000	T2000	T2000	T2000	T2000		T2000	T2000	T2000	T2000	T2000

Refer to **the latest Ryco Digital Crimp Tools** for crimping parameters.

RYCO HOSE TYPE APPROVALS																
HOSE SERIES	DIEHARD	SLIDER	SURVIVOR	ENERGY	ICEBREAKER	ABS	DNV-GL	LR	MED	USCG	DOT	GOST-R	BV	RINA	KR	MA-KA
T6000	D	S	S ^v	E	I											
T6004	•	•				T2000	T2000	T2000	T2000	T2000		T2000	T2000	T2000	T2000	
T6005	•	•				T2000	T2000	T2000	T2000	T2000		T2000	T2000	T2000	T2000	
T6006	•	•				T2000	T2000	T2000	T2000	T2000		T2000	T2000	T2000	T2000	
H3000	D	S	S ^v	E	I											
H3020	•	•				T7000	T7000	T7000	T7000	T7000		T7000	T7000	T7000	T7000	
H3024	•	•				T7000	T7000	T7000	T7000	T7000		T7000	T7000	T7000	T7000	
H3032	•	•				T7000	T7000	T7000	T7000	T7000		T7000	T7000	T7000	T7000	
H4000	D	S	S ^v	E	I											
H4006	•	•				T7000	T7000	T7000	T7000	T7000		T7000	T7000	T7000	T7000	
H4008	•	•				T7000	T7000	T7000	T7000	T7000		T7000	T7000	T7000	T7000	
H4010	•	•				T7000	T7000	T7000	T7000	T7000		T7000	T7000	T7000	T7000	
H4012	•	•				T7000	T7000	T7000	T7000	T7000		T7000	T7000	T7000	T7000	
H4016	•	•				T7000	T7000	T7000	T7000	T7000		T7000	T7000	T7000	T7000	
H4020	•	•				T7000	T7000	T7000	T7000	T7000		T7000	T7000	T7000	T7000	
H4024	•	•				T7000	T7000	T7000	T7000	T7000		T7000	T7000	T7000	T7000	
H4032	•	•				T7000	T7000	T7000	T7000	T7000		T7000	T7000	T7000	T7000	
H5000	D	S	S ^v	E	I											
H5006	•	•				T7000	T7000	T7000	T7000	T7000		T7000	T7000	T7000	T7000	
H5008	•	•				T7000	T7000	T7000	T7000	T7000		T7000	T7000	T7000	T7000	
H5010	•	•				T7000	T7000	T7000	T7000	T7000		T7000	T7000	T7000	T7000	
H5012	•	•			•	T7000	T7000	T7000	T7000	T7000		T7000	T7000	T7000	T7000	
H5016	•	•			•	T7000	T7000	T7000	T7000	T7000		T7000	T7000	T7000	T7000	
H5020	•	•			•	T7000	T7000	T7000	T7000	T7000		T7000	T7000	T7000	T7000	
H5024	•	•			•	T6000 & T7000	T6000 & T7000	T6000 & T7000	T6000 & T7000	T6000 & T7000		T6000 & T7000	T6000 & T7000	T6000 & T7000	T6000 & T7000	
H5032	•	•				T6000	T6000	T6000	T6000	T6000		T6000	T6000	T6000	T6000	
H6000	D	S	S ^v	E	I											
H6006	•	•				T7000	T7000	T7000	T7000	T7000		T7000	T7000	T7000	T7000	
H6008	•	•				T7000	T7000	T7000	T7000	T7000		T7000	T7000	T7000	T7000	
H6010	•	•				T7000	T7000	T7000	T7000	T7000		T7000	T7000	T7000	T7000	
H6012	•	•				T6000 & T7000	T6000 & T7000	T6000 & T7000	T6000 & T7000	T6000 & T7000		T6000 & T7000	T6000 & T7000	T6000 & T7000	T6000 & T7000	
H6016	•	•				T6000 & T7000	T6000 & T7000	T6000 & T7000	T6000 & T7000	T6000 & T7000		T6000 & T7000	T6000 & T7000	T6000 & T7000	T6000 & T7000	
H6020	•	•				T6000 & T7000	T6000 & T7000	T6000 & T7000	T6000 & T7000	T6000 & T7000		T6000 & T7000	T6000 & T7000	T6000 & T7000	T6000 & T7000	
H6024	•	•				T6000	T6000	T6000	T6000	T6000		T6000	T6000	T6000	T6000	
H6032	•	•				T6000	T6000	T6000	T6000	T6000		T6000	T6000	T6000	T6000	

Refer to **the latest Ryco Digital Crimp Tools** for crimping parameters.

INTRODUCTION

HOSES

TECHNICAL

HOSES

HOSE TYPE APPROVALS

HOSE SERIES	RYCO HOSE TYPE APPROVALS														
	DIEHARD	SLIDER	SURVIVOR	ENERGY	ICEBREAKER	ABS	DNV-GL	LR	MED	USCG	DOT	GOST-R	BV	RINA	KR

DF1	D	S	S'	E	I											
DF14	•					T2000	T2000	T2000	T2000	T2000		T2000	T2000	T2000	T2000	
DF15	•					T2000	T2000	T2000	T2000	T2000		T2000	T2000	T2000	T2000	
DF16	•					T2000	T2000	T2000	T2000	T2000		T2000	T2000	T2000	T2000	
DF18	•					T2000	T2000	T2000	T2000	T2000		T2000	T2000	T2000	T2000	
DF110	•					T2000	T2000	T2000	T2000	T2000		T2000	T2000	T2000	T2000	
DF112	•					T2000	T2000	T2000	T2000	T2000		T2000	T2000	T2000	T2000	
DF116	•					T2000	T2000	T2000	T2000	T2000		T2000	T2000	T2000	T2000	

DF2	D	S	S'	E	I											
DF24	•					T2000	T2000	T2000	T2000	T2000		T2000	T2000	T2000	T2000	
DF25	•					T2000	T2000	T2000	T2000	T2000		T2000	T2000	T2000	T2000	
DF26	•					T2000	T2000	T2000	T2000	T2000		T2000	T2000	T2000	T2000	
DF28	•					T2000	T2000	T2000	T2000	T2000		T2000	T2000	T2000	T2000	
DF210	•					T2000	T2000	T2000	T2000	T2000		T2000	T2000	T2000	T2000	
DF212	•					T2000	T2000	T2000	T2000	T2000		T2000	T2000	T2000	T2000	
DF216	•					T2000	T2000	T2000	T2000	T2000		T2000	T2000	T2000	T2000	
DF220	•					T2000				T2000		T2000			T2000	

T1	D	S	S'	E	I											
T13	•	•				T2000	T2000	T2000	T2000	T2000		T2000	T2000	T2000	T2000	T2000
T14	•	•				T2000	T2000	T2000	T2000	T2000		T2000	T2000	T2000	T2000	T2000
T15	•	•				T2000	T2000	T2000	T2000	T2000		T2000	T2000	T2000	T2000	T2000
T16	•	•				T2000	T2000	T2000	T2000	T2000		T2000	T2000	T2000	T2000	T2000
T18	•	•				T2000	T2000	T2000	T2000	T2000		T2000	T2000	T2000	T2000	T2000
T110	•	•				T2000	T2000	T2000	T2000	T2000		T2000	T2000	T2000	T2000	T2000
T112	•	•				T2000	T2000	T2000	T2000	T2000		T2000	T2000	T2000	T2000	T2000
T116	•	•				T2000	T2000	T2000	T2000	T2000		T2000	T2000	T2000	T2000	T2000
T120	•	•				T2000	T2000	T2000	T2000	T2000		T2000	T2000	T2000	T2000	T2000
T124	•	•				T2000	T2000	T2000	T2000	T2000		T2000	T2000	T2000	T2000	T2000
T132	•	•				T2000	T2000	T2000	T2000	T2000		T2000	T2000	T2000	T2000	T2000

T1F	D	S	S'	E	I											
T13F						T2000	T2000	T2000	T2000	T2000		T2000	T2000	T2000	T2000	
T14F						T2000	T2000	T2000	T2000	T2000		T2000	T2000	T2000	T2000	
T16F						T2000	T2000	T2000	T2000	T2000		T2000	T2000	T2000	T2000	
T18F						T2000	T2000	T2000	T2000	T2000		T2000	T2000	T2000	T2000	
T112F						T2000	T2000	T2000	T2000	T2000		T2000	T2000	T2000	T2000	

T2	D	S	S'	E	I											
T24	•	•			•	T2000	T2000	T2000	T2000	T2000		T2000	T2000	T2000	T2000	T2000
T25	•	•			•	T2000	T2000	T2000	T2000	T2000		T2000	T2000	T2000	T2000	T2000
T26	•	•			•	T2000 & T7000	T2000 & T7000	T2000 & T7000	T2000 & T7000	T2000 & T7000		T2000 & T7000	T2000 & T7000	T2000 & T7000	T2000 & T7000	T2000 & T7000
T28	•	•			•	T2000 & T7000	T2000 & T7000	T2000 & T7000	T2000 & T7000	T2000 & T7000		T2000 & T7000	T2000 & T7000	T2000 & T7000	T2000 & T7000	T2000 & T7000
T210	•	•			•	T2000 & T7000	T2000 & T7000	T2000 & T7000	T2000 & T7000	T2000		T2000 & T7000	T2000 & T7000	T2000 & T7000	T2000 & T7000	T2000 & T7000
T212	•	•			•	T2000 & T7000	T2000 & T7000	T2000 & T7000	T2000 & T7000	T2000 & T7000		T2000 & T7000	T2000 & T7000	T2000 & T7000	T2000 & T7000	T2000 & T7000
T216	•	•			•	T2000 & T7000	T2000 & T7000	T2000 & T7000	T2000 & T7000	T7000		T2000 & T7000	T2000 & T7000	T2000 & T7000	T2000 & T7000	T2000 & T7000
T220	•	•			•	T2000 & T7000	T2000 & T7000	T2000 & T7000	T2000 & T7000	T7000		T2000 & T7000	T2000 & T7000	T2000 & T7000	T2000 & T7000	T2000 & T7000
T224	•	•			•	T7000	T7000	T7000	T7000	T7000		T7000	T7000	T7000	T7000	T7000
T232	•	•			•	T7000	T7000	T7000	T7000	T7000		T7000	T7000	T7000	T7000	T7000

RYCO HOSE TYPE APPROVALS																
HOSE SERIES	DIEHARD	SLIDER	SURVIVOR	ENERGY	ICEBREAKER	ABS	DNV-GL	LR	MED	USCG	DOT	GOST-R	BV	RINA	KR	MA-KA
TXA2D	D	S	S ^v	E	I											
TXA28D	•					T2000	T2000	T2000	T2000	T2000		T2000	T2000	T2000	T2000	
TXA210D	•					T2000	T2000	T2000	T2000	T2000		T2000	T2000	T2000	T2000	
TXA212D	•					T2000	T2000	T2000	T2000	T2000		T2000	T2000	T2000	T2000	
TXA216D	•					T2000	T2000	T2000	T2000	T2000		T2000	T2000	T2000	T2000	
H12	D	S	S ^v	E	I											
H1206	•	•				T7000	T7000	T7000	T7000	T7000		T7000	T7000	T7000	T7000	
H1208	•	•				T7000	T7000	T7000	T7000	T7000		T7000	T7000	T7000	T7000	
H1210	•	•				T7000	T7000	T7000	T7000	T7000		T7000	T7000	T7000	T7000	
H1212	•	•				T7000	T7000	T7000	T7000	T7000		T7000	T7000	T7000	T7000	
H1216	•	•				T7000	T7000	T7000	T7000	T7000		T7000	T7000	T7000	T7000	
H1220	•	•				T7000	T7000	T7000	T7000	T7000		T7000	T7000	T7000	T7000	
H1224	•	•				T7000	T7000	T7000	T7000	T7000		T7000	T7000	T7000	T7000	
H1232	•	•				T7000	T7000	T7000	T7000	T7000		T7000	T7000	T7000	T7000	
4SP	D	S	S ^v	E	I											
4SP06	•					T7000	T7000	T7000	T7000	T7000		T7000	T7000	T7000	T7000	T7000
4SP08	•					T7000	T7000	T7000	T7000	T7000		T7000	T7000	T7000	T7000	T7000
4SP08	•					T7000	T7000	T7000	T7000	T7000		T7000	T7000	T7000	T7000	T7000
4SP10						T7000	T7000	T7000	T7000	T7000		T7000	T7000	T7000	T7000	T7000
4SP12	•					T7000	T7000	T7000	T7000	T7000		T7000	T7000	T7000	T7000	T7000
4SP16	•					T7000	T7000	T7000	T7000	T7000		T7000	T7000	T7000	T7000	T7000
4SH	D	S	S ^v	E	I											
4SH12	•					T7000	T7000	T7000	T7000	T7000		T7000	T7000	T7000	T7000	T7000
4SH16	•					T6000	T6000	T6000	T6000	T6000		T6000	T6000	T6000	T6000	T6000
4SH20	•					T7000	T7000	T7000	T7000	T7000		T7000	T7000	T7000	T7000	T7000
4SH24	•					T7000	T7000	T7000	T7000	T7000		T7000	T7000	T7000	T7000	T7000
4SH32	•					T7000	T7000	T7000	T7000	T7000		T7000	T7000	T7000	T7000	T7000
SURVIVOR/1	D	S	S ^v	E	I											
SVR14			•			T2000	T2000	T2000	T2000	T2000		T2000	T2000	T2000	T2000	
SVR15			•			T2000	T2000	T2000	T2000	T2000		T2000	T2000	T2000	T2000	
SVR16			•			T2000	T2000	T2000	T2000	T2000		T2000	T2000	T2000	T2000	
SVR18			•			T2000	T2000	T2000	T2000	T2000		T2000	T2000	T2000	T2000	
SVR110			•			T2000	T2000	T2000	T2000	T2000		T2000	T2000	T2000	T2000	
SVR112			•			T2000	T2000	T2000	T2000	T2000		T2000	T2000	T2000	T2000	
SVR116			•			T2000	T2000	T2000	T2000	T2000		T2000	T2000	T2000	T2000	

Refer to **the latest Ryco Digital Crimp Tools** for crimping parameters.



INTRODUCTION

HOSES

TECHNICAL

HOSES

HOSE TYPE APPROVALS

RYCO HOSE TYPE APPROVALS																	
HOSE SERIES	DIEHARD	SLIDER	SURVIVOR	ENERGY	ICEBREAKER												
SURVIVOR/2	D	S	S^v	E	I												
SVR24			•			T2000	T2000	T2000	T2000	T2000		T2000	T2000	T2000	T2000		
SVR25			•			T2000	T2000	T2000	T2000	T2000		T2000	T2000	T2000	T2000		
SVR26			•			T2000 & T7000	T2000 & T7000	T2000 & T7000	T2000 & T7000	T2000 & T7000		T2000 & T7000	T2000 & T7000	T2000 & T7000	T2000 & T7000		
SVR28			•			T2000 & T7000	T2000 & T7000	T2000 & T7000	T2000 & T7000	T2000 & T7000		T2000 & T7000	T2000 & T7000	T2000 & T7000	T2000 & T7000		
SVR210			•			T2000 & T7000	T2000 & T7000	T2000 & T7000	T2000 & T7000	T2000 & T7000		T2000 & T7000	T2000 & T7000	T2000 & T7000	T2000 & T7000		
SVR212			•			T2000 & T7000	T2000 & T7000	T2000 & T7000	T2000 & T7000	T2000 & T7000		T2000 & T7000	T2000 & T7000	T2000 & T7000	T2000 & T7000		
SVR216			•			T2000 & T7000	T2000 & T7000	T2000 & T7000	T2000 & T7000	T2000 & T7000		T2000 & T7000	T2000 & T7000	T2000 & T7000	T2000 & T7000		
SVR220			•			T2000 & T7000	T2000 & T7000	T2000 & T7000	T2000 & T7000	T7000		T7000	T2000 & T7000	T2000 & T7000	T2000 & T7000		
SVR224			•			T7000	T7000	T7000	T7000	T7000		T7000	T7000	T7000	T7000		
*SURVIVOR/R5	D	S	S^v	E	I												
SVR56						T4000	T4000	T4000	T4000	T4000	T4000	T4000	T4000	T4000	T4000		
SVR58						T4000	T4000	T4000	T4000	T4000	T4000	T4000	T4000	T4000	T4000		
SVR510						T4000	T4000	T4000	T4000	T4000	T4000	T4000	T4000	T4000	T4000		
SVR512						T4000	T4000	T4000	T4000	T4000	T4000	T4000	T4000	T4000	T4000		
D2B	D	S	S^v	E	I												
D220B			•			T7000	T7000	T7000	T7000	T7000		T7000	T7000	T7000	T7000		
D224B			•			T7000 & T2000	T7000 & T2000	T7000 & T2000	T7000 & T2000	T7000 & T2000		T7000 & T2000	T7000 & T2000	T7000 & T2000	T7000 & T2000		
D232B			•			T7000 & T2000	T7000 & T2000	T7000 & T2000	T7000 & T2000	T7000 & T2000		T7000 & T2000	T7000 & T2000	T7000 & T2000	T7000 & T2000		
*T5	D	S	S^v	E	I												
T54						T4000	T4000	T4000	T4000	T4000	T4000	T4000	T4000	T4000	T4000		
T55						T4000	T4000	T4000	T4000	T4000	T4000	T4000	T4000	T4000	T4000		
T56						T4000	T4000	T4000	T4000	T4000	T4000	T4000	T4000	T4000	T4000		
T58						T4000	T4000	T4000	T4000	T4000	T4000	T4000	T4000	T4000	T4000		
T510						T4000	T4000	T4000	T4000	T4000	T4000	T4000	T4000	T4000	T4000		
T512						T4000	T4000	T4000	T4000	T4000	T4000	T4000	T4000	T4000	T4000		
T516						T4000	T4000	T4000	T4000	T4000	T4000	T4000	T4000	T4000	T4000		
T520						T4000	T4000	T4000	T4000	T4000	T4000	T4000	T4000	T4000	T4000		
T524						V000	V000	V000	V000	V000	V000	V000	V000	V000	V000		
T532						V000	V000	V000	V000	V000	V000	V000	V000	V000	V000		

* NOTE: For marine application Type Approval compliance, FS1072 FIRESLEEVE and FSTAPE must be used with Ryco RTH1, SR, SRF/P, SRX/HT, T5 and SURVIVOR/R5 hose.

Refer to **the latest Ryco Digital** Crimp Tools for crimping parameters.

RYCO HOSE TYPE APPROVALS																
HOSE SERIES	DIEHARD	SLIDER	SURVIVOR	ENERGY	ICEBREAKER	ABS	DNV-GL	LR	MED	USCG	DOT	GOST-R	BV	RINA	KR	MA-KA
BT1	D	S	S ^v	E	I											
BT14			•			T2000	T2000	T2000	T2000	T2000		T2000	T2000	T2000	T2000	
BT15			•			T2000	T2000	T2000	T2000	T2000		T2000	T2000	T2000	T2000	
BT16			•			T2000	T2000	T2000	T2000	T2000		T2000	T2000	T2000	T2000	
BT18			•			T2000	T2000	T2000	T2000	T2000		T2000	T2000	T2000	T2000	
BT110			•			T2000	T2000	T2000	T2000	T2000		T2000	T2000	T2000	T2000	
BT112			•			T2000	T2000	T2000	T2000	T2000		T2000	T2000	T2000	T2000	
BT116			•			T2000	T2000	T2000	T2000	T2000		T2000	T2000	T2000	T2000	
*SRF/P	D	S	S ^v	E	I											
SRFP12						T4000	T4000	T4000	T4000	T4000		T4000	T4000	T4000	T4000	
SRFP16						T4000	T4000	T4000	T4000	T4000		T4000	T4000	T4000	T4000	
SRFP20						T4000	T4000	T4000	T4000	T4000		T4000	T4000	T4000	T4000	
SRFP24						T4000	T4000	T4000	T4000	T4000		T4000	T4000	T4000	T4000	
SRFP32						T4000	T4000	T4000	T4000	T4000		T4000	T4000	T4000	T4000	
*RTH1	D	S	S ^v	E	I											
RTH14						TT000	TT000	TT000	TT000	TT000		TT000	TT000	TT000	TT000	
RTH16						TT000	TT000	TT000	TT000	TT000		TT000	TT000	TT000	TT000	
RTH18						TT000	TT000	TT000	TT000	TT000		TT000	TT000	TT000	TT000	
RTH110						TT000	TT000	TT000	TT000	TT000		TT000	TT000	TT000	TT000	
RTH112						TT000	TT000	TT000	TT000	TT000		TT000	TT000	TT000	TT000	
RTH116						TT000	TT000	TT000	TT000	TT000		TT000	TT000	TT000	TT000	

* NOTE: For marine application Type Approval compliance, FS1072 FIRESLEEVE and FSTAPE must be used with Ryco RTH1, SRF/P, SRX/HT, T5 and SURVIVOR/R5 hose.

Refer to **the latest Ryco Digital Crimp Tools** for crimping parameters.

INTRODUCTION

HOSES

TECHNICAL



DIEHARD

HOSE THAT WONT SAY DIE

EXTRA ABRASION RESISTANT

FRAS-FLAME RESISTANT ANTI STATIC

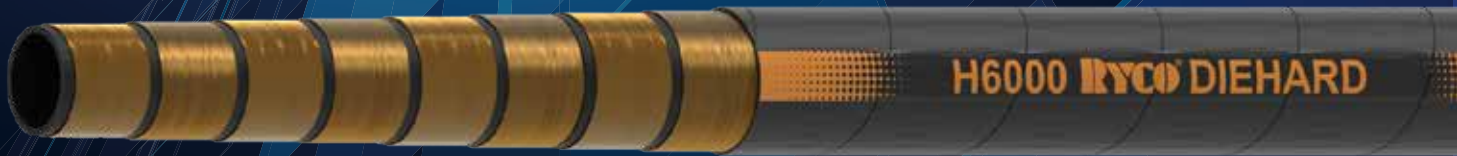

RYCO QUALITY

HIGHLY FLEXIBLE



SURVIVOR

THE HEAT IS ON

HIGH TEMPERATURE RESISTANCE

MSHA - FLAME RESISTANT

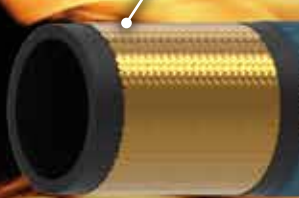

RYCO SURVIVOR / R5

RYCO QUALITY

MULTI FLUID

HOSE COVERS



RYCO ENERGY

ENERGY AND PERFORMANCE

- **ABRASION RESISTANT**
- **OZONE RESISTANT**
- **STANDARD AND COMPACT HOSE TYPES**

Ryco **ENERGY COMPACT** will ensure the hydraulic system will meet the endurance required to get the job done.

Constructed with two braids of high tensile steel wire, the specially formulated black synthetic cover is oil resistant, and ideally suited for the agricultural market.

Ryco **ENERGY COMPACT** is available in sizes ranging from 1/4" (-04) to 1" (-16) and meets or exceeds the performance requirements of SAE 100R16. Ryco **ENERGY COMPACT** has been designed and manufactured to match with Ryco's T2000 series coupling range.

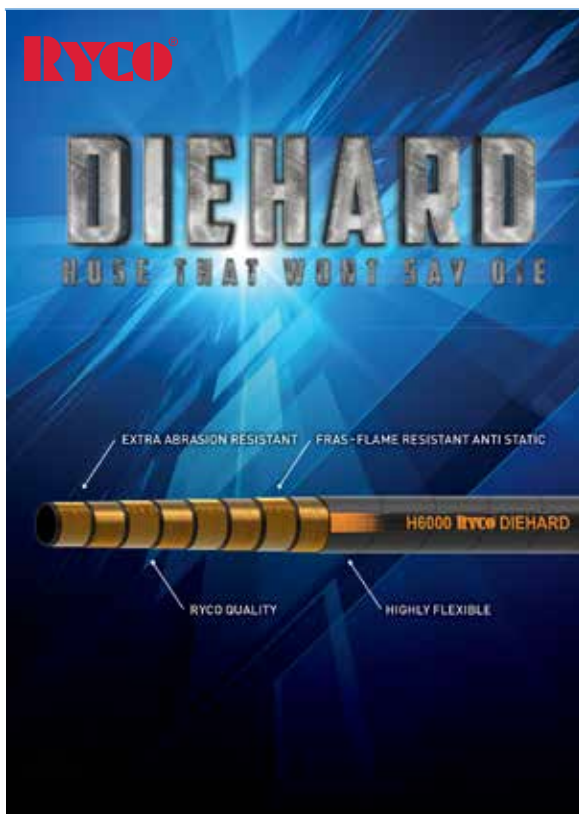

RYCO DIEHARD™

HOSE THAT WON'T SAY DIE

- **EXTRA ABRASION RESISTANT**
- **MSHA FLAME RESISTANT**
- **FRAS FLAME RESISTANT & ANTI-STATIC**

DIEHARD™ has a synthetic rubber cover that is extra resistant to abrasion and complies with Flame Resistant and Anti-Static (FRAS) requirements of AS 2660 methods of test AS 1180.10B and AS 1180.13A, also meeting USA MSHA requirements. **DIEHARD™** complies with ISO 6945 method of test for abrasion resistance being less than 10% of the maximum weight loss allowed by EN 853, EN 856 and EN 857.

HYDRAULIC HOSE COVERS TO SUIT YOUR NEEDS

Ryco Hose styles cover a broad range of hydraulic applications. Different applications require different performance criteria. Ryco ENERGY, DIEHARD™, SLIDER and SURVIVOR™ tube and cover compounds offer a perfect choice and are available across a range of our Hose Styles.

RYCO SLIDER

GIVE ABRASION THE SLIP

- EXTREMELY ABRASION RESISTANT
- MSHA FLAME RESISTANT

SLIDER has an additional layer of polyethylene protection over the rubber cover of the hose. The result is an extremely abrasion resistant cover that complies with Flame Resistant requirement of AS 2660 method of test AS1180.10B, meeting USA MSHA requirements. SLIDER complies with ISO 6945 method of test for abrasion resistance being less than 0.2% of that allowed by EN 853, EN 856 and EN 857.

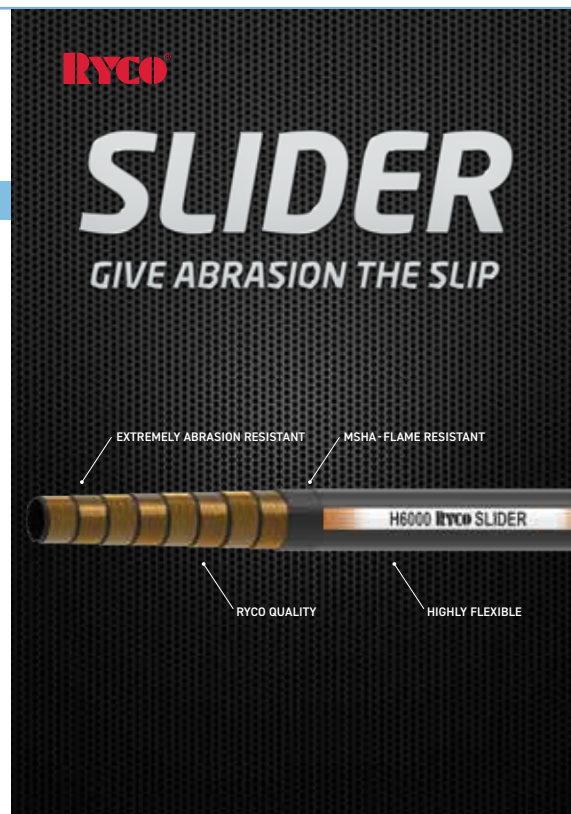

RYCO SURVIVOR™

THE HEAT IS ON

- HIGH TEMPERATURE (150°C/302°F)
- MSHA FLAME RESISTANT

Designed for high temperature applications and suitable for use with a variety of fluids.





SLIDER

GIVE ABRASION THE SLIP

EXTREMELY ABRASION RESISTANT

MSHA-FLAME RESISTANT

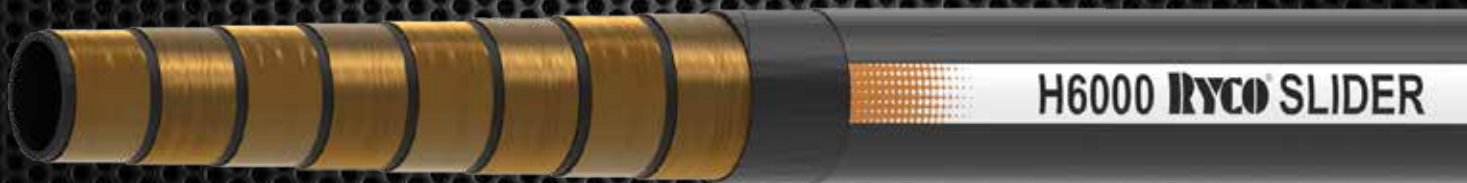

RYCO QUALITY

HIGHLY FLEXIBLE

MAXIMUM WORKING PRESSURES

Maximum Working Pressures shown below (except for **Ryco PL1D, PL1PV**) are Dynamic Working Pressures for use with hydraulic fluid in systems with pressure surges or variable loads and are based on 4:1 safety factor (minimum burst to maximum working pressure).

Ryco PL1D, PL1PV and hoses are recommended for use with **Ryco 8000 Series** Push-On Fittings in systems with Static Working Pressures only, and are not recommended for vibration or pressure surge applications. The Maximum Working Pressures for **PL1D** , and **PL1PV** shown below are Static Working Pressures.

Hose subjected to both maximum temperature and maximum working pressure will have a shortened lifetime.

HOSE SIZE			T3000D/S	T3600C/D/S	T4000D/S	T5000D/S	T6000D/S	H3000D/S	H4000D/S	H5000C/D/S	H6000D/S	C6000D/S	DF1D	DF2D	DK1D/E/S	DK2E/S	EC1	EC2	E1	E2	T1D/S	T1F	T2D/S	T2C	TXA2D	H12D/S
DN	INCH	DASH	BAR																							
3	1/8	-02																								
5	3/16	-03																				250	250			
6	1/4	-04	215	250	280	350	420						225	420	295	450	225	400	225	400	225	225	420	420		
8	5/16	-05	215	250	280	350	420						215	350	250	420	215	350	215	350	215	215	350	350		
10	3/8	-06	215	250	280	350	420		280	350	420		180	350	230	385	180	330	180	330	180	180	350	350		350
12	1/2	-08	215	250	280	350			280	350	420		160	295	200	345	160	275	160	275	160	160	350	350	375	350
16	5/8	-10	215	250	280				280	350	420		130	250	150	290	130	250	130	250	130	130	250	250	350	350
19	3/4	-12	215	250	280				280	350	420	420	105	215	125	280	105	215	105	215	105	105	215	215	315	350
25	1	-16	215	250					280	350	420	420	90	170	110	200	90	165	90	165	90	90	175	175	225	350
31	1.1/4	-20							215	280	350	420		140	100	175					65		140	140		275
38	1.1/2	-24							215	280	350	420									50		100	100		255
51	2	-32							215	280	350	420									40		90	90		210
63	2.1/2	-40																					105			140
76	3	-48																					80			

HOSE SIZE			TJ2D	D4000D	SURVIVOR/1	SURVIVOR/2	SURVIVOR/R5	D2B	T5	MS1000	CS1000	BT1	SW	JS4000/g/GX/BX	JS6000/g/GX/BX	SRF/P	SRX/HT	RTH1	PL1D	PL1PV
DN	INCH	DASH																		
3	1/8	-02																		
5	3/16	-03																		
6	1/4	-04	700		225	400	210		210			50		280	420			170	30	30
8	5/16	-05			215	350	210		210			50		280	420				30	30
10	3/8	-06	700		180	350	157		157			50	1250	280	420			165	30	30
12	1/2	-08		280	160	300	140		140	70	70	50	1100	280	420			120	30	30
16	5/8	-10			130	250			122	70	70	50	1000					105	26	26
19	3/4	-12		280	105	215			105	70	70	50	700			21	25	85	22	22
25	1	-16		280	90	167			56	70	70	50	700			17	25	55		
31	1.1/4	-20			65	150		140	43	70	70					14	17			
38	1.1/2	-24			50	100		100	35	70	70					11	17			
51	2	-32			40	90		90	24	70	70					7	10			
63	2.1/2	-40			35											4	10			
76	3	-48			35											4	7			
89	3.1/2	-56														3	5			
102	4	-64														3	5			

INTRODUCTION

HOSES

TECHNICAL

HOSES

SPECIFICATIONS SUMMARY

MAXIMUM WORKING PRESSURES (CONT)

HOSE SIZE			MP1	TP7, TP7N	TP7T, TP7TN	TP8, TP8N	TP8T, TP8TN	TP3000	TPGL
DN	INCH	DASH							
3	1/8	-02							250
5	3/16	-03		210					
6	1/4	-04	13,8	210	210	350	350	210	
8	5/16	-05		190	190				
10	3/8	-06	13,8	160	160	280	280	210	
12	1/2	-08	13,8	140	140	245	245	210	
16	5/8	-10	13,8						
19	3/4	-12	13,8	90					
25	1	-16	13,8	70					
31	1.1/4	-20	13,8						
38	1.1/2	-24							
51	2	-32							
63	2.1/2	-40							
76	3	-48							

PRESSURE CONVERSION CHART																
1 BAR = 14.5 PSI 1 MPA = 10 BAR																
bar	4	7	10	12	14	17	20	24	28	39	55	69	80	90	120	130
psi	58	100	145	175	200	250	300	350	400	565	800	1000	1160	1300	1740	1890
bar	160	180	200	215	225	250	300	337	350	375	400	420	435	500	585	690
psi	2300	2600	2900	3100	3250	3600	4350	4900	5100	5440	5800	6080	6310	7250	8480	10000

The Working Pressure of each Hose Coupling End Termination Style is shown in the Technical section. In most cases, the Working Pressure of the Hose Coupling End Termination Style that can be chosen for a particular hose exceeds the Maximum Working Pressure of the Hose.

It is possible however, to select a Hose Coupling with End Termination with lower Working Pressure than the Hose. In this case, as noted in SAE J516 and SAE J517, the rated Working Pressure of the Hose Assembly must not exceed the lower of the respective Working Pressure rated values.

EXAMPLE 1.

T28D Hose Assembly with T2030-0812 coupling one end and T2090-0808 coupling other end.

From above table or from page 101, Maximum Working Pressure of T28D is 350 bar.

From page 203 and the technical section pages 496 to 500 the Maximum Working Pressure of T2030-0812 is 690 bar.

From page 199, and the technical section pages 496 to 500 the Maximum Working Pressure of T2090-0808 is 690 bar.

The Maximum Working Pressure of the Hose Assembly is therefore 350 bar, the lowest of the respective Working Pressure rated values (in this case, the hose).

EXAMPLE 2.

H5016D Hose Assembly with T7130-1620 coupling one end and T7030-1621 coupling other end.

From above table or from page 78, Maximum Working Pressure of H5016D is 350 bar.

From page 292 and the technical section pages 496 to 500 the Maximum Working Pressure of T7130-1620 is 280 bar.

From page 280 and the technical section pages 496 to 500 the Maximum Working Pressure of T7030-1621 is 420 bar.

The Maximum Working Pressure of the Hose Assembly is therefore 280 bar, the lowest of the respective Working Pressure rated values (in this case, the T7130-1620).

See page 188 for more information.

IMPULSE LIFE

Although two or more hoses manufactured to different industry standard specifications may have identical Maximum Working Pressures, their suitability for the application must be considered. An important factor to consider is the magnitude and frequency of the pressure impulses that the hose assembly will experience.

FLAME RESISTANCE

All Ryco Hoses (except **Ryco JS, T3600C, H5000C, MP1, PW2, TW1, TP7, TP7N, TP7T, TP7TN, TP8, TP8N, TP8T, TP8TN, TP3000, SURVIVOR/R5, SRX/HT, SRF/P, T5, RTH1 & PL1** Series) meet Flame Resistant Designation "U.S. MSHA" of the U.S. Department of Labor, Mine Safety and Health Administration and also comply with Flame Resistant requirements of Australian Standard AS 2660 and Method of Test AS 1180.10B. Contact Ryco Technical Department for more information.

MINIMUM BEND RADIUS

Minimum Bend Radius figures published are the radius to the cover of the Hose at the inside of the bend.

Ryco Hose Assemblies exceed the required impulse test requirements when bent to the published Minimum Bend Radius. Hose assemblies bent to smaller than the Minimum Bend Radius will have shortened lifetime.

ANTI-STATIC

"Anti-Static" refers to Hoses or Hose Assemblies being sufficiently electrically conductive to drain off static electricity. According to the requirements of AS 2660 Clause 2.2, the Hose or Hose assembly shall have an electrical resistance (measured from inside surface to outside surface) of less than 1 megohm per metre, when tested according to Method of Test AS 1180.13A. For applications requiring Anti-Static Hydraulic Hose Assemblies including, but not limited to, underground coal mines, where there is danger of ignition from static electricity discharge, only special Anti-Static Hose can be used.

Ryco DIEHARD™ Hoses and COALSPRAY comply with the requirements of AS 2660 and Method of Test AS 1180.13A.

NON CONDUCTIVE

Certain applications require that a Hose, or Hose Assembly, be Non-Conductive to prevent electrical current flow. For applications that require a Hose to be electrically Non-Conductive including, but not limited to, applications near high voltage electric lines, only special Non-Conductive Hoses can be used.

SKIVE/NON-SKIVE

Skiving refers to removing the cover at the ends of the Hose where the Hose Couplings are to be attached*. Most Ryco combinations of Hose and Couplings are Non-Skive.

In a Non-Skive application, Ryco couplings bite down through the cover and grip the wire reinforcement. Some combinations of Ryco Hose and Couplings require skiving. If skiving is required, it is clearly stated in both the Hose Section and the Couplings Section.

OUTSIDE DIAMETERS

See page 153 for reference chart of outside diameters.

SAFETY GUIDE – MAXIMUM TEMPERATURE LIMITS

Some Ryco Hose Series are not listed on page 58: **T1F, TJ2D, RTH1, MP1**.

These Hoses are specific purpose Hoses, and their temperature limits are specified in the Hose Section of this Product Technical Manual. Contact Ryco Technical Department for any further queries.

Other Ryco Hose Series are listed on page 58. The Maximum Working Temperatures for these hoses, as listed in the Hose Section of this Product Technical Manual are for use with general purpose, mineral (petroleum) oil based hydraulic fluids, except where otherwise stated. Temperature limits for other hydraulic fluids, and some other common applications, are listed on page 58.

CAUTION:

Life expectancy of hoses is shortened at high temperatures. Detrimental effects increase when temperature is elevated, and also when; operating pressure, flow velocity, duration and frequency of exposure, and level of impurities in the media are high. Actual service life at temperatures approaching the recommended limits will depend on the particular application and the fluid being used.

Maximum Working Temperatures refer to the temperature of the media in the hose; not the environmental temperature around the outside of the hose. Please contact Ryco Technical Department for environmental temperatures in excess of 80°C (176°F), except **SURVIVOR/1, SURVIVOR/2, SURVIVOR/R5** and where environmental temperature is the same as media temperature.

Maximum Working Temperatures shown are for continuous temperatures. Slightly higher intermittent temperatures (up to 10% of time) may be acceptable with some hoses and some fluids, if reduced service life is acceptable. Please contact Ryco Technical Department for more information.

DO NOT expose Hose to Maximum Temperature and Maximum Working Pressure at the same time.

The fluid manufacturer's recommended maximum operating temperature for the fluid must not be exceeded. If different to the temperatures listed in the following table, the lower limit must take precedence. We recommend keeping the hose filled with the pressure medium at all times. Further information available on request.

ISOBARIC HOSE

1/2 BEND RADIUS

MILLION CYCLE

PERFORMANCE AT A GLANCE:

H SERIES ISOBARIC SPIRAL HOSE

- Half SAE minimum bend radius.
- Highly flexible for easier routing and installation.
- Isobaric pressure from 215 bar/3100 psi (H3000) to 420 bar/6100 psi (H6000).
- Lighter weight means your hydraulic system is more compact and economical.
- 81 products in the H series Spiral range.
- Includes "World First" H6032 2" (DN51) hose.

T SERIES ISOBARIC BRAID HOSE

- Half SAE minimum bend radius.
- Highly flexible for easier routing and installation.
- Isobaric pressure from 215 bar/3100 psi (T3000) to 420 bar/6100 psi (T6000).
- Lighter weight means your hydraulic system is more compact and economical.
- 81 products in the T series Braid hose range.
- T3000 Braid is proven to impulse test of one million cycles in all sizes.
- Meets and exceeds the performance requirements of ISO 18752 (all series).

T3000D

**EXTRA ABRASION RESISTANT
FRAS
COMPACT ISOBARIC HOSE
215 BAR / 3100 PSI
MILLION CYCLE**

RECOMMENDED FOR:

High pressure hydraulic oil lines. Constant pressure (isobaric) 215 bar / 3100 psi in all sizes. Small bend radius and compact dimensions are advantages in installations.

PERFORMANCE:

Meets or Exceeds the Performance Requirements of: ISO 18752-BC, SAE 100R17.

TUBE:

Black, oil resistant synthetic rubber.

REINFORCEMENT:

One braid (-04 to -08 size) or two braids (-10 to -16 size) of high tensile steel wire.

COVER:

DIEHARD™ Black, oil and extra abrasion resistant synthetic rubber. Flame Resistant, Anti-Static (FRAS) & MSHA compliant. Highly visible layline branding for easy and permanent identification. No skiving required with T2000 Series Crimp Couplings.

FEATURES:

Tested to **1 million impulse cycles**.

Constant pressure 215 bar / 3100 psi in all sizes for easy system design and hose selection. Small bend radius and compact dimensions are advantages in installations.

FRAS - FLAME RESISTANCE AND ANTI-STATIC:

DIEHARD™ complies with Flame Resistant and Electrical Resistance (Anti-Static) requirements of Australian Standard AS 2660 and Methods of Test AS 1180.10B and 13A. Meets Flame Resistant Designation "U.S. MSHA" of the US Department of Labor, Mine Safety and Health Administration.

TEMPERATURE RANGE:

-40°C to +100°C (-40°F to +212°F).

For water, emulsions etc. see page 58.

WORKING PRESSURE:

Maximum working pressures are based on 4:1 safety factor (maximum working pressure to minimum burst pressure).

THIRD PARTY APPROVALS:

ABS, DNV-GL, LR, MED, USCG, CLASSNK, GOST-R, BV, RINA and KR.

COUPLINGS:
NON-SKIVE ONE-PIECE CRIMP

T2000 Series (sizes -04 to -16).

Assembly Instructions pages 146.

T3000D - DIEHARD															
PART NO	HOSE SIZE	NOMINAL HOSE ID		NOMINAL HOSE OD		MAXIMUM WORKING PRESSURE		MINIMUM BURST PRESSURE		MINIMUM BEND RADIUS		AVERAGE WEIGHT		COUPLING SERIES ONE PIECE	
Hose	DN	Dash	mm	inch	mm	inch	bar	psi	bar	psi	mm	inch	kg/m	lb/ft	NON-SKIVE
T3004D	6	-04	6,6	1/4	11,8	0.46	245	3500	980	14000	38	1.5	0,16	0.11	T2000
T3005D	8	-05	8,2	5/16	14,4	0.57	245	3500	980	14000	40	1.6	0,23	0.15	T2000
T3006D	10	-06	9,8	3/8	15,6	0.61	215	3100	860	12400	65	2.6	0,26	0.18	T2000
T3008D	12	-08	13,0	1/2	18,7	0.74	215	3100	860	12400	90	3.6	0,36	0.24	T2000
T3010D	16	-10	16,2	5/8	23,4	0.92	215	3100	860	12400	100	3.9	0,56	0.38	T2000
T3012D	19	-12	19,1	3/4	27,6	1.09	215	3100	860	12400	120	4.7	0,78	0.52	T2000
T3016D	25	-16	25,4	1	34,8	1.37	215	3100	860	12400	150	5.9	1,14	0.77	T2000

Refer to the latest Ryco Digital Crimp Tools for crimping parameters.

HOSES

ISOBARIC BRAID

T3000S

EXTREMELY ABRASION RESISTANT
MSHA
COMPACT ISOBARIC HOSE
215 BAR / 3100 PSI
MILLION CYCLE



RECOMMENDED FOR:

High pressure hydraulic oil lines. Constant pressure (Isobaric) 215 bar / 3100 psi in all sizes. Small bend radius and compact dimensions are advantages in installations.

PERFORMANCE:

Meets or Exceeds the Performance Requirements of: ISO 18752-BC, SAE 100R17.

TUBE:

Black, oil resistant synthetic rubber.

REINFORCEMENT:

One braid (-04 to -08 size) or two braids (-10 to -16 size) of high tensile steel wire.

COVER:

SLIDER Black, oil and extremely abrasion resistant synthetic rubber sheathed with a layer of extremely abrasion resistant polyethylene. Flame Resistant, MSHA compliant. Highly visible layline branding for easy and permanent identification. No skiving required with T2000 Series Crimp Couplings.

FEATURES:

Tested to **1 million impulse cycles**.

Constant pressure 215 bar / 3100 psi in all sizes for easy system design and hose selection. Small bend radius and compact dimensions are advantages in installations.

MSHA - FLAME RESISTANCE:

SLIDER complies with Flame Resistant requirements of Australian Standard AS 2660 and Methods of Test AS 1180.10B. Meets Flame Resistant Designation "U.S. MSHA" of the US Department of Labor, Mine Safety and Health Administration.

TEMPERATURE RANGE:

-40°C to +100°C (-40°F to +212°F).
 For water, emulsions etc. see page 58.

WORKING PRESSURE:

Maximum working pressures are based on 4:1 safety factor (maximum working pressure to minimum burst pressure).

THIRD PARTY APPROVALS:

ABS, DNV-GL, LR, MED, USCG, GOST-R, BV, RINA and KR.

COUPLINGS:

NON-SKIVE ONE-PIECE CRIMP

T2000 Series (sizes -04 to -16).
 Assembly Instructions pages 146.

T3000S - SLIDER															
PART NO	HOSE SIZE	NOMINAL HOSE ID		NOMINAL HOSE OD		MAXIMUM WORKING PRESSURE		MINIMUM BURST PRESSURE		MINIMUM BEND RADIUS		AVERAGE WEIGHT		COUPLING SERIES ONE PIECE	
Hose	DN	Dash	mm	inch	mm	inch	bar	psi	bar	psi	mm	inch	kg/m	lb/ft	NON-SKIVE
T3004S	6	-04	6,6	1/4	11,8	0.46	245	3500	980	14000	38	1.5	0,16	0.11	T2000
T3005S	8	-05	8,2	5/16	14,4	0.57	245	3500	980	14000	40	1.6	0,23	0.15	T2000
T3006S	10	-06	9,8	3/8	15,6	0.61	215	3100	860	12400	65	2.6	0,26	0.18	T2000
T3008S	12	-08	13,0	1/2	18,7	0.74	215	3100	860	12400	90	3.6	0,36	0.24	T2000
T3010S	16	-10	16,2	5/8	23,4	0.92	215	3100	860	12400	100	3.9	0,56	0.38	T2000
T3012S	19	-12	19,1	3/4	27,6	1.09	215	3100	860	12400	120	4.7	0,78	0.52	T2000
T3016S	25	-16	25,4	1	34,8	1.37	215	3100	860	12400	150	5.9	1,14	0.77	T2000

Refer to the latest Ryco Digital Crimp Tools for crimping parameters.

T3600C

**LOW TEMPERATURE
COMPACT ISOBARIC HOSE
250 BAR / 3625 PSI**

RECOMMENDED FOR:

High pressure hydraulic oil lines in applications where low temperature environmental conditions exist.

PERFORMANCE:

Meets or Exceeds the Performance Requirements of: ISO 18752-BC.

TUBE:

Black, specially formulated oil resistant synthetic rubber.

REINFORCEMENT:

One braid (-04 to -06 size) or two braids (-08 to -16 size) of high tensile wire.

COVER:

Black, oil resistant and abrasion resistant synthetic rubber. No skiving required with T2000 Series Crimp Couplings.

FEATURES:

Extremely Flexible. Minimum Bend Radius 25% less than published SAE 100R17 Minimum Bend Radius. Tested to 500,000 cycles. Constant pressure 250 bar / 3625 psi in all sizes for easy system design and hose selection. Small bend radius and compact dimensions are advantages in installations.

TEMPERATURE RANGE:

From -60°C to +100°C (-76°F to +212°F).

For water, emulsions etc. see page 58.

WORKING PRESSURE:

Maximum working pressures are based on 4:1 safety factor (maximum working pressure to minimum burst pressure).

THIRD PARTY APPROVALS:

ABS, DNV-GL, LR, MED, USCG, GOST-R, BV, RINA and KR.

COUPLINGS:
NON-SKIVE ONE-PIECE CRIMP

T2000 Series (sizes -04 to -16).

Assembly Instructions pages 146.

T3600C- DIEHARD															
PART NO	HOSE SIZE	NOMINAL HOSE ID		NOMINAL HOSE OD		MAXIMUM WORKING PRESSURE		MINIMUM BURST PRESSURE		MINIMUM BEND RADIUS		AVERAGE WEIGHT		COUPLING SERIES ONE PIECE	
Hose	DN	Dash	mm	inch	mm	inch	bar	psi	bar	psi	mm	inch	kg/m	lb/ft	NON-SKIVE
T3604C	6	-04	6,6	1/4	11,8	0.46	250	3625	1000	14500	38	1.5	0,16	0.11	T2000
T3605C	8	-05	8,2	5/16	14,4	0.57	250	3625	1000	14500	40	1.6	0,23	0.15	T2000
T3606C	10	-06	9,8	3/8	15,6	0.61	250	3625	1000	14500	49	1.9	0,27	0.18	T2000
T3608C	12	-08	13,0	1/2	19,9	0.78	250	3625	1000	14500	68	2.7	0,45	0.30	T2000
T3610C	16	-10	16,2	5/8	23,4	0.92	250	3625	1000	14500	75	3.0	0,61	0.41	T2000
T3612C	19	-12	19,1	3/4	27,6	1.09	250	3625	1000	14500	90	3.6	0,78	0.52	T2000
T3616C	25	-16	25,4	1	35,2	1.39	250	3625	1000	14500	115	4.5	1,30	0.87	T2000

Refer to the latest Ryco Digital Crimp Tools for crimping parameters.

HOSES

ISOBARIC BRAID

T3600D

EXTRA ABRASION RESISTANT
FRAS
COMPACT ISOBARIC HOSE
250 BAR / 3625 PSI



RECOMMENDED FOR:

High pressure hydraulic oil lines. Constant pressure (Isobaric) 250 bar / 3625 psi in all sizes. Small bend radius and compact dimensions are advantages in installations.

PERFORMANCE:

Meets or Exceeds the Performance Requirements of: ISO 18752-BC.

TUBE:

Black, oil resistant synthetic rubber.

REINFORCEMENT:

One braid (-04 to -06 size) or two braids (-08 to -16 size) of high tensile wire.

COVER:

DIEHARD™ Black, oil and extra abrasion resistant synthetic rubber. Flame Resistant, Anti-Static (FRAS) & MSHA compliant. Highly visible layline branding for easy and permanent identification. No skiving required with T2000 Series Crimp Couplings.

FEATURES:

Extremely Flexible. Minimum Bend Radius 25% less than published SAE 100R17 Minimum Bend Radius. Tested to 500,000 impulse cycles. Constant pressure 250 bar / 3625 psi in all sizes for easy system design and hose selection. Small bend radius and compact dimensions are advantages in installations.

FRAS - FLAME RESISTANCE AND ANTI-STATIC:

DIEHARD™ complies with Flame Resistant and Electrical Resistance (Anti-Static) requirements of Australian Standard AS 2660 and Methods of Test AS 1180.10B and 13A. Meets Flame Resistant Designation "U.S. MSHA" of the US Department of Labor, Mine Safety and Health Administration.

TEMPERATURE RANGE:

-40°C to +100°C (-40°F to +212°F).
For water, emulsions etc. see page 58.

WORKING PRESSURE:

Maximum working pressures are based on 4:1 safety factor (maximum working pressure to minimum burst pressure).

THIRD PARTY APPROVALS:

ABS, DNV-GL, LR, MED, USCG, GOST-R, BV, RINA and KR.

COUPLINGS:

NON-SKIVE ONE-PIECE CRIMP

T2000 Series (sizes -04 to -16).
Assembly Instructions pages 146.

T3600D - DIEHARD															
PART NO	HOSE SIZE	NOMINAL HOSE ID		NOMINAL HOSE OD		MAXIMUM WORKING PRESSURE		MINIMUM BURST PRESSURE		MINIMUM BEND RADIUS		AVERAGE WEIGHT		COUPLING SERIES ONE PIECE	
Hose	DN	Dash	mm	inch	mm	inch	bar	psi	bar	psi	mm	inch	kg/m	lb/ft	NON-SKIVE
T3604D	6	-04	6,6	1/4	11,8	0.46	250	3625	1000	14500	38	1.5	0,16	0.11	T2000
T3605D	8	-05	8,2	5/16	14,4	0.57	250	3625	1000	14500	40	1.6	0,23	0.15	T2000
T3606D	10	-06	9,8	3/8	15,6	0.61	250	3625	1000	14500	49	1.9	0,27	0.18	T2000
T3608D	12	-08	13,0	1/2	19,9	0.78	250	3625	1000	14500	68	2.7	0,45	0.30	T2000
T3610D	16	-10	16,2	5/8	23,4	0.92	250	3625	1000	14500	75	3.0	0,61	0.41	T2000
T3612D	19	-12	19,1	3/4	27,6	1.09	250	3625	1000	14500	90	3.6	0,78	0.52	T2000
T3616D	25	-16	25,4	1	35,2	1.39	250	3625	1000	14500	115	4.5	1,30	0.87	T2000

Refer to the latest Ryco Digital Crimp Tools for crimping parameters.

T3600S

**EXTREMELY ABRASION RESISTANT
COMPACT ISOBARIC HOSE
250 BAR / 3625 PSI**











RECOMMENDED FOR:

High pressure hydraulic oil lines. Constant pressure (isobaric) 250 bar / 3625 psi in all sizes. Small bend radius and compact dimensions are advantages in installations.

PERFORMANCE:

Meets or Exceeds the Performance Requirements of: ISO 18752-BC.

TUBE:

Black, oil resistant synthetic rubber.

REINFORCEMENT:

One braid (-04 to -06 size) or two braids (-08 to -16 size) of high tensile wire.

COVER:

SLIDER Black, oil and extremely abrasion resistant synthetic rubber sheathed with a layer of extremely abrasion resistant polyethylene. Flame Resistant, MSHA compliant. Highly visible layline branding for easy and permanent identification. No skiving required with T2000 Series Crimp Couplings.

FEATURES:

Extremely Flexible. Minimum Bend Radius 25% less than published SAE 100R17 Minimum Bend Radius. Tested to 500,000 impulse cycles. Constant pressure 250 bar / 3625 psi in all sizes for easy system design and hose selection. Small bend radius and compact dimensions are advantages in installations.

MSHA - FLAME RESISTANCE:

SLIDER complies with Flame Resistant requirements of Australian Standard AS 2660 and Methods of Test AS 1180.10B. Meets Flame Resistant Designation "U.S. MSHA" of the US Department of Labor, Mine Safety and Health Administration.

TEMPERATURE RANGE:

-40°C to +100°C (-40°F to +212°F).
For water, emulsions etc. see page 58.

WORKING PRESSURE:







Maximum working pressures are based on 4:1 safety factor (maximum working pressure to minimum burst pressure).

THIRD PARTY APPROVALS:

ABS, DNV-GL, LR, MED, USCG, GOST-R, BV, RINA and KR.

COUPLINGS:

NON-SKIVE ONE-PIECE CRIMP T2000 Series (sizes -04 to -16).
Assembly Instructions pages 146.

T3600S - SLIDER															
PART NO	HOSE SIZE	NOMINAL HOSE ID		NOMINAL HOSE OD		MAXIMUM WORKING PRESSURE		MINIMUM BURST PRESSURE		MINIMUM BEND RADIUS		AVERAGE WEIGHT		COUPLING SERIES ONE PIECE	
Hose	DN	Dash	mm	inch	mm	inch	bar	psi	bar	psi	mm	inch	kg/m	lb/ft	NON-SKIVE
T3604S	6	-04	6,6	1/4	11,8	0.46	250	3625	1000	14500	38	1.5	0,16	0.11	T2000
T3605S	8	-05	8,2	5/16	14,4	0.57	250	3625	1000	14500	40	1.6	0,23	0.15	T2000
T3606S	10	-06	9,8	3/8	15,6	0.61	250	3625	1000	14500	49	1.9	0,27	0.18	T2000
T3608S	12	-08	13,0	1/2	19,9	0.78	250	3625	1000	14500	68	2.7	0,45	0.30	T2000
T3610S	16	-10	16,2	5/8	23,4	0.92	250	3625	1000	14500	75	3.0	0,61	0.41	T2000
T3612S	19	-12	19,1	3/4	27,6	1.09	250	3625	1000	14500	90	3.6	0,78	0.52	T2000
T3616S	25	-16	25,4	1	35,2	1.39	250	3625	1000	14500	115	4.5	1,30	0.87	T2000

Refer to the latest Ryco Digital Crimp Tools for crimping parameters.

HOSES

ISOBARIC BRAID

T4000D

EXTRA ABRASION RESISTANT
FRAS
COMPACT ISOBARIC HOSE
280 BAR / 4100 PSI



RECOMMENDED FOR:

High pressure hydraulic oil lines. Constant pressure (Isobaric) 280 bar / 4100 psi in all sizes. Small bend radius and compact dimensions are advantages in installations.

PERFORMANCE:

Meets or Exceeds the Performance Requirements of: ISO 18752-BC, SAE 100R19.

TUBE:

Black, oil resistant synthetic rubber.

REINFORCEMENT:

One braid (-04 size) or two braids (-05 to -12 size) of high tensile wire.

COVER:

DIEHARD™ Black, oil and extra abrasion resistant synthetic rubber. Flame Resistant, Anti-Static (FRAS) & MSHA compliant. Highly visible layline branding for easy and permanent identification.

FEATURES:

Constant pressure 280 bar / 4100 psi in all sizes for easy system design and hose selection. Small bend radius and compact dimensions are advantages in installations.

FRAS - FLAME RESISTANCE AND ANTI-STATIC:

DIEHARD™ complies with Flame Resistant and Electrical Resistance (Anti-Static) requirements of Australian Standard AS 2660 and Methods of Test AS 1180.10B and 13A. Meets Flame Resistant Designation "U.S. MSHA" of the US Department of Labor, Mine Safety and Health Administration.

TEMPERATURE RANGE:

-40°C to +100°C (-40°F to +212°F).
For water, emulsions etc. see page 58.

WORKING PRESSURE:

Maximum working pressures are based on 4:1 safety factor (maximum working pressure to minimum burst pressure).

THIRD PARTY APPROVALS:

ABS, DNV-GL, LR, MED, USCG, GOST-R, BV, RINA and KR.

COUPLINGS:

NON-SKIVE ONE-PIECE CRIMP

T2000 Series (sizes -04 to -12).
Assembly Instructions pages 146.

T4000D - DIEHARD															
PART NO	HOSE SIZE	NOMINAL HOSE ID		NOMINAL HOSE OD		MAXIMUM WORKING PRESSURE		MINIMUM BURST PRESSURE		MINIMUM BEND RADIUS		AVERAGE WEIGHT		COUPLING SERIES ONE PIECE	
Hose	DN	Dash	mm	inch	mm	inch	bar	psi	bar	psi	mm	inch	kg/m	lb/ft	NON-SKIVE
T4004D	6	-04	6,6	1/4	11,8	0.46	280	4100	1120	16400	50	2.0	0,17	0.12	T2000
T4005D	8	-05	8,2	5/16	15,6	0.61	280	4100	1120	16400	55	2.2	0,34	0.23	T2000
T4006D	10	-06	9,8	3/8	16,6	0.65	280	4100	1120	16400	65	2.6	0,37	0.25	T2000
T4008D	12	-08	13,0	1/2	20,6	0.81	280	4100	1120	16400	90	3.6	0,51	0.34	T2000
T4010D	16	-10	16,2	5/8	23,4	0.92	280	4100	1120	16400	100	3.9	0,61	0.41	T2000
T4012D	19	-12	19,1	3/4	28,4	1.12	280	4100	1120	16400	120	4.7	0,92	0.62	T2000

Refer to the latest Ryco Digital Crimp Tools for crimping parameters.

T4000S

**EXTREMELY ABRASION RESISTANT
MSHA
COMPACT ISOBARIC HOSE
280 BAR / 4100 PSI**





RECOMMENDED FOR:

High pressure hydraulic oil lines. Constant pressure (Isobaric) 280 bar / 4100 psi in all sizes. Small bend radius and compact dimensions are advantages in installations.

PERFORMANCE:

Meets or Exceeds the Performance Requirements of: ISO 18752-BC, SAE 100R19.

TUBE:

Black, oil resistant synthetic rubber.

REINFORCEMENT:

One braid (-04 size) or two braids (-05 to -12 size) of high tensile wire.

COVER:

SLIDER Black, oil and extremely abrasion resistant synthetic rubber sheathed with a layer of extremely abrasion resistant polyethylene. Flame Resistant, MSHA compliant. Highly visible layline branding for easy and permanent identification.

FEATURES:

Constant pressure 280 bar / 4100 psi in all sizes for easy system design and hose selection. Small bend radius and compact dimensions are advantages in installations.

MSHA - FLAME RESISTANCE:

SLIDER complies with Flame Resistant requirements of Australian Standard AS 2660 and Methods of Test AS 1180.10B. Meets Flame Resistant Designation "U.S. MSHA" of the US Department of Labor, Mine Safety and Health Administration.

TEMPERATURE RANGE:

-40°C to +100°C (-40°F to +212°F).

WORKING PRESSURE:

Maximum working pressures are based on 4:1 safety factor (maximum working pressure to minimum burst pressure).







THIRD PARTY APPROVALS:

ABS, DNV-GL, LR, MED, USCG, GOST-R, BV, RINA and KR.

COUPLINGS:

NON-SKIVE ONE-PIECE CRIMP

T2000 Series (sizes -04 to -12).
Assembly Instructions pages 146.

T4000S - SLIDER															
PART NO	HOSE SIZE	NOMINAL HOSE ID		NOMINAL HOSE OD		MAXIMUM WORKING PRESSURE		MINIMUM BURST PRESSURE		MINIMUM BEND RADIUS		AVERAGE WEIGHT		COUPLING SERIES ONE PIECE	
Hose	DN	Dash	mm	inch	mm	inch	bar	psi	bar	psi	mm	inch	kg/m	lb/ft	NON-SKIVE
T4004S	6	-04	6,6	1/4	11,8	0.46	280	4100	1120	16400	50	2.0	0,17	0.12	T2000
T4005S	8	-05	8,2	5/16	15,6	0.61	280	4100	1120	16400	55	2.2	0,34	0.23	T2000
T4006S	10	-06	9,8	3/8	16,6	0.65	280	4100	1120	16400	65	2.6	0,37	0.25	T2000
T4008S	12	-08	13,0	1/2	20,6	0.81	280	4100	1120	16400	90	3.6	0,51	0.34	T2000
T4010S	16	-10	16,2	5/8	23,4	0.92	280	4100	1120	16400	100	3.9	0,61	0.41	T2000
T4012S	19	-12	19,1	3/4	28,4	1.12	280	4100	1120	16400	120	4.7	0,92	0.62	T2000

Refer to the latest Ryco Digital Crimp Tools for crimping parameters.

HOSES

ISOBARIC BRAID

T5000D

EXTRA ABRASION RESISTANT
FRAS
COMPACT ISOBARIC HOSE
350 BAR / 5100 PSI



RECOMMENDED FOR:

Very high pressure hydraulic oil lines. Constant pressure (Isobaric) 350 bar / 5100 psi in all sizes. Small bend radius and compact dimensions are advantages in installations.

PERFORMANCE:

Meets or Exceeds the Performance Requirements of: ISO 18752-BC.

TUBE:

Black, oil resistant synthetic rubber.

REINFORCEMENT:

Two braids of high tensile steel wire.

COVER:

DIEHARD™ Black, oil and extra abrasion resistant synthetic rubber. Flame Resistant, Anti-Static (FRAS) & MSHA compliant. Highly visible layline branding for easy and permanent identification. No skiving required with T2000 Series Crimp Couplings.

FEATURES:

Constant pressure 350 bar / 5100 psi in all sizes for easy system design and hose selection. Small bend radius and compact dimensions are advantages in installations.

FRAS - FLAME RESISTANCE AND ANTI-STATIC:

DIEHARD™ complies with Flame Resistant and Electrical Resistance (Anti-Static) requirements of Australian Standard AS 2660 and Methods of Test AS 1180.10B and 13A. Meets Flame Resistant Designation "U.S. MSHA" of the US Department of Labor, Mine Safety and Health Administration.

TEMPERATURE RANGE:

-40°C to +100°C (-40°F to +212°F).

For water, emulsions etc. see page 58.

WORKING PRESSURE:

Maximum working pressures are based on 4:1 safety factor (maximum working pressure to minimum burst pressure).

THIRD PARTY APPROVALS:

ABS, DNV-GL, LR, MED, USCG, GOST-R, BV, RINA and KR.

COUPLINGS:

NON-SKIVE ONE-PIECE CRIMP

T2000 Series (sizes -04 to -16).

Assembly Instructions pages 146.

T5000D - DIEHARD															
PART NO	HOSE SIZE	NOMINAL HOSE ID		NOMINAL HOSE OD		MAXIMUM WORKING PRESSURE		MINIMUM BURST PRESSURE		MINIMUM BEND RADIUS		AVERAGE WEIGHT		COUPLING SERIES ONE PIECE	
Hose	DN	Dash	mm	inch	mm	inch	bar	psi	bar	psi	mm	inch	kg/m	lb/ft	NON-SKIVE
T5004D	6	-04	6,6	1/4	13,2	0.52	350	5100	1400	20400	50	2.0	0,28	0.19	T2000
T5005D	8	-05	8,2	5/16	15,6	0.61	350	5100	1400	20400	55	2.2	0,34	0.23	T2000
T5006D	10	-06	9,8	3/8	17,1	0.67	350	5100	1400	20400	65	2.6	0,41	0.28	T2000
T5008D	12	-08	13,0	1/2	20,6	0.81	350	5100	1400	20400	90	3.6	0,57	0.38	T2000

Refer to the latest Ryco Digital Crimp Tools for crimping parameters.

T5000S

EXTREMELY ABRASION RESISTANT
MSHA
COMPACT ISOBARIC HOSE
350 BAR / 5100 PSI

RECOMMENDED FOR:

Very high pressure hydraulic oil lines. Constant pressure (isobaric) 350 bar / 5100 psi in all sizes. Small bend radius and compact dimensions are advantages in installations.

PERFORMANCE:

Meets or Exceeds the Performance Requirements of: ISO 18752-BC.

TUBE:

Black, oil resistant synthetic rubber.

REINFORCEMENT:

Two braids of high tensile steel wire.

COVER:

SLIDER Black, oil and extremely abrasion resistant synthetic rubber sheathed with a layer of extremely abrasion resistant polyethylene. Flame Resistant, MSHA compliant. Highly visible layline branding for easy and permanent identification. No skiving required with T2000 Series Crimp Couplings.

FEATURES:

Constant pressure 350 bar/5100 psi in all sizes for easy system design and hose selection. Small bend radius and compact dimensions are advantages in installations.

MSHA - FLAME RESISTANCE:

SLIDER complies with Flame Resistant requirements of Australian Standard AS 2660 and Methods of Test AS 1180.10B. Meets Flame Resistant Designation "U.S. MSHA" of the US Department of Labor, Mine Safety and Health Administration.

TEMPERATURE RANGE:

-40°C to +100°C (-40°F to +212°F).
For water, emulsions etc. see page 58.

WORKING PRESSURE:

Maximum working pressures are based on 4:1 safety factor (maximum working pressure to minimum burst pressure).

THIRD PARTY APPROVALS:

ABS, DNV-GL, LR, MED, USCG, GOST-R, BV, RINA and KR.

COUPLINGS:
NON-SKIVE ONE-PIECE CRIMP

T2000 Series (sizes -04 to -08).
Assembly Instructions pages 146.

T5000S - SLIDER															
PART NO	HOSE SIZE	NOMINAL HOSE ID		NOMINAL HOSE OD		MAXIMUM WORKING PRESSURE		MINIMUM BURST PRESSURE		MINIMUM BEND RADIUS		AVERAGE WEIGHT		COUPLING SERIES ONE PIECE	
Hose	DN	Dash	mm	inch	mm	inch	bar	psi	bar	psi	mm	inch	kg/m	lb/ft	NON-SKIVE
T5004S	6	-04	6,6	1/4	13,2	0.52	350	5100	1400	20400	50	2.0	0,28	0.19	T2000
T5005S	8	-05	8,2	5/16	15,6	0.61	350	5100	1400	20400	55	2.2	0,34	0.23	T2000
T5006S	10	-06	9,8	3/8	17,1	0.67	350	5100	1400	20400	65	2.6	0,41	0.28	T2000
T5008S	12	-08	13,0	1/2	20,6	0.81	350	5100	1400	20400	90	3.6	0,57	0.38	T2000

Refer to the latest Ryco Digital Crimp Tools for crimping parameters.

HOSES

ISOBARIC BRAID

T6000D

EXTRA ABRASION RESISTANT
FRAS
COMPACT ISOBARIC HOSE
420 BAR / 6100 PSI



RECOMMENDED FOR:

Extremely high pressure hydraulic oil lines. Constant pressure (Isobaric) 420 bar / 6100 psi in all sizes. Small bend radius and compact dimensions are advantages in installations.

PERFORMANCE:

Meets or Exceeds the Performance Requirements of: ISO 18752-BC.

TUBE:

Black, oil resistant synthetic rubber.

REINFORCEMENT:

Two braids of high tensile steel wire.

COVER:

DIEHARD™ Black, oil and extra abrasion resistant synthetic rubber. Flame Resistant, Anti-Static (FRAS) & MSHA compliant. Highly visible layline branding for easy and permanent identification. No skiving required with T2000 Series Crimp Couplings.

FEATURES:

Constant pressure 420 bar / 6100 psi in all sizes for easy system design and hose selection. Small bend radius and compact dimensions are advantages in installations.

FRAS - FLAME RESISTANCE AND ANTI-STATIC:

DIEHARD™ complies with Flame Resistant and Electrical Resistance (Anti-Static) requirements of Australian Standard AS 2660 and Methods of Test AS 1180.10B and 13A. Meets Flame Resistant Designation "U.S. MSHA" of the US Department of Labor, Mine Safety and Health Administration.

TEMPERATURE RANGE:

-40°C to +100°C (-40°F to +212°F).
For water, emulsions etc. see page 58.

WORKING PRESSURE:

Maximum working pressures are based on 4:1 safety factor (maximum working pressure to minimum burst pressure).

THIRD PARTY APPROVALS:

ABS, DNV-GL, LR, MED, USCG, GOST-R, BV, RINA and KR.

COUPLINGS:

NON-SKIVE ONE-PIECE CRIMP

T2000 Series (sizes -04 to -06).
Assembly Instructions pages 146.

T6000D - DIEHARD															
PART NO	HOSE SIZE	NOMINAL HOSE ID	NOMINAL HOSE OD	MAXIMUM WORKING PRESSURE		MINIMUM BURST PRESSURE		MINIMUM BEND RADIUS		AVERAGE WEIGHT		COUPLING SERIES ONE PIECE			
Hose	DN	Dash	mm	inch	mm	inch	bar	psi	bar	psi	mm	inch	kg/m	lb/ft	NON-SKIVE
T6004D	6	-04	6,6	1/4	13,2	0.52	420	6100	1680	24400	50	2.0	0,28	0.19	T2000
T6005D	8	-05	8,2	5/16	15,6	0.61	420	6100	1680	24400	55	2.2	0,35	0.24	T2000
T6006D	10	-06	9,8	3/8	17,6	0.69	420	6100	1680	24400	65	2.6	0,47	0.32	T2000

Refer to the latest Ryco Digital Crimp Tools for crimping parameters.

T6000S

**EXTREMELY ABRASION RESISTANT
MSHA
COMPACT ISOBARIC HOSE
420 BAR / 6100 PSI**

RECOMMENDED FOR:

Extremely high pressure hydraulic oil lines. Constant pressure (Isobaric) 420 bar / 6100 psi in all sizes. Small bend radius and compact dimensions are advantages in installations.

PERFORMANCE:

Meets or Exceeds the Performance Requirements of: ISO 18752-BC.

TUBE:

Black, oil resistant synthetic rubber.

REINFORCEMENT:

Two braids of high tensile steel wire.

COVER:

SLIDER Black, oil and extremely abrasion resistant synthetic rubber sheathed with a layer of extremely abrasion resistant polyethylene. Flame Resistant, MSHA compliant. Highly visible layline branding for easy and permanent identification. No skiving required with T2000 Series Crimp Couplings.

FEATURES:

Constant pressure 420 bar / 6100 psi in all sizes for easy system design and hose selection. Small bend radius and compact dimensions are advantages in installations.

MSHA - FLAME RESISTANCE:

SLIDER complies with Flame Resistant requirements of Australian Standard AS 2660 and Methods of Test AS 1180.10B. Meets Flame Resistant Designation "U.S. MSHA" of the US Department of Labor, Mine Safety and Health Administration.

TEMPERATURE RANGE:

-40°C to +100°C (-40°F to +212°F).
For water, emulsions etc. see page 58.

WORKING PRESSURE:

Maximum working pressures are based on 4:1 safety factor (maximum working pressure to minimum burst pressure).

THIRD PARTY APPROVALS:

ABS, DNV-GL, LR, MED, USCG, GOST-R, BV, RINA and KR.

COUPLINGS:
NON-SKIVE ONE-PIECE CRIMP

T2000 Series (sizes -04 to -06).
Assembly Instructions pages 146.

T6000S - SLIDER															
PART NO	HOSE SIZE	NOMINAL HOSE ID		NOMINAL HOSE OD		MAXIMUM WORKING PRESSURE		MINIMUM BURST PRESSURE		MINIMUM BEND RADIUS		AVERAGE WEIGHT		COUPLING SERIES ONE PIECE	
Hose	DN	Dash	mm	inch	mm	inch	bar	psi	bar	psi	mm	inch	kg/m	lb/ft	NON-SKIVE
T6004S	6	-04	6,6	1/4	13,2	0.52	420	6100	1680	24400	50	2.0	0,28	0.19	T2000
T6005S	8	-05	8,2	5/16	15,6	0.61	420	6100	1680	24400	55	2.2	0,35	0.24	T2000
T6006S	10	-06	9,8	3/8	17,6	0.69	420	6100	1680	24400	65	2.6	0,47	0.32	T2000

Refer to the latest Ryco Digital Crimp Tools for crimping parameters.

HOSES

ISOBARIC SPIRAL

H3000D

EXTRA ABRASION RESISTANT
FRAS

ISOBARIC SPIRAL HOSE

215 BAR / 3100 PSI

MILLION CYCLE



RECOMMENDED FOR:

High pressure hydraulic oil lines. Constant pressure (Isobaric) 215 bar / 3100 psi in all sizes. Small bend radius is an advantage in installations.

PERFORMANCE:

Meets or Exceeds the Performance Requirements of: EN 856 Type R12, EN 856 Type 4SP, ISO 18752-DC, SAE 100R12.

TUBE:

Black, oil resistant synthetic rubber.

REINFORCEMENT:

Four alternating layers of spiralled high tensile steel wire.

COVER:

DIEHARD™ Black, oil and extra abrasion resistant synthetic rubber. Flame Resistant, Anti-Static (FRAS) & MSHA compliant. Highly visible layline branding for easy and permanent identification. No skiving required with T7000 Series Crimp Couplings.

FEATURES:

Tested to **1 million impulse cycles** at up to 1/2 SAE 100R12 Minimum Bend Radius. Constant pressure 215 bar / 3100 psi in all sizes for easy system design and hose selection. Small bend radius is an advantage in installations.

FRAS - FLAME RESISTANCE AND ANTI-STATIC:

DIEHARD™ complies with Flame Resistant and Electrical Resistance (Anti-Static) requirements of Australian Standard AS 2660 and Methods of Test AS 1180.10B and 13A. Meets Flame Resistant Designation "U.S. MSHA" of the US Department of Labor, Mine Safety and Health Administration.

TEMPERATURE RANGE:

-40°C to +121°C (-40°F to +250°F).
For water, emulsions etc. see page 58.

WORKING PRESSURE:

Maximum working pressures are based on 4:1 safety factor (maximum working pressure to minimum burst pressure).

THIRD PARTY APPROVALS:

ABS, DNV-GL, LR, MED, USCG, GOST-R, BV, RINA and KR.

COUPLINGS:

NON-SKIVE ONE-PIECE CRIMP

T7000 Series (sizes -20 to -32).
Assembly Instructions pages 146.

H3000D - DIEHARD		NOMINAL HOSE ID		NOMINAL HOSE OD		MAXIMUM WORKING PRESSURE		MINIMUM BURST PRESSURE		MINIMUM BEND RADIUS		AVERAGE WEIGHT		COUPLING SERIES ONE PIECE
PART NO	HOSE SIZE	mm	inch	mm	inch	bar	psi	bar	psi	mm	inch	kg/m	lb/ft	NON-SKIVE
H3020D	31 -20	31,8	1.1/4	45,7	1.80	215	3100	860	12400	200	7.9	2,27	1.53	T7000
H3024D	38 -24	38,1	1.1/2	50,3	1.98	215	3100	860	12400	250	9.8	2,35	1.58	T7000
H3032D	51 -32	50,8	2	63,3	2.49	215	3100	860	12400	400	15.8	3,40	2.28	T7000

Refer to the latest Ryco Digital Crimp Tools for crimping parameters.

H3000S

EXTREMELY ABRASION RESISTANT
MSHA
ISOBARIC SPIRAL HOSE
215 BAR / 3100 PSI
MILLION CYCLE

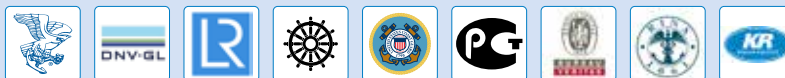

INTRODUCTION

HOSES

TECHNICAL

RECOMMENDED FOR:

High pressure hydraulic oil lines. Constant pressure (Isobaric) 215 bar / 3100 psi in all sizes. Small bend radius is an advantage in installations.

PERFORMANCE:

Meets or Exceeds the Performance Requirements of: EN 856 Type R12, EN 856 Type 4SP, ISO 18752-DC, SAE 100R12.

TUBE:

Black, oil resistant synthetic rubber.

REINFORCEMENT:

Four alternating layers of spiralled high tensile steel wire.

COVER:

SLIDER Black, oil and extremely abrasion resistant synthetic rubber sheathed with a layer of extremely abrasion resistant polyethylene. Flame Resistant, MSHA compliant. Highly visible layline branding for easy and permanent identification. No skiving required with T7000 Series Crimp Couplings.

FEATURES:

Tested to **1 million impulse cycles** at up to 1/2 SAE 100R12 Minimum Bend Radius. Constant pressure 215 bar / 3100 psi in all sizes for easy system design and hose selection. Small bend radius is an advantage in installations.

MSHA - FLAME RESISTANCE:

SLIDER complies with Flame Resistant requirements of Australian Standard AS 2660 and Methods of Test AS 1180.10B. Meets Flame Resistant Designation "U.S. MSHA" of the US Department of Labor, Mine Safety and Health Administration.

TEMPERATURE RANGE:

-40°C to +121°C (-40°F to +250°F).
 For water, emulsions etc. see page 58.

WORKING PRESSURE:

Maximum working pressures are based on 4:1 safety factor (maximum working pressure to minimum burst pressure).

THIRD PARTY APPROVALS:

ABS, DNV-GL, LR, MED, USCG, GOST-R, BV, RINA and KR.

COUPLINGS:

NON-SKIVE ONE-PIECE CRIMP

T7000 Series (sizes -20 to -32).
 Assembly Instructions pages 146.

H3000S - SLIDER															
PART NO	HOSE SIZE	NOMINAL HOSE ID		NOMINAL HOSE OD		MAXIMUM WORKING PRESSURE		MINIMUM BURST PRESSURE		MINIMUM BEND RADIUS		AVERAGE WEIGHT		COUPLING SERIES ONE PIECE	
Hose	DN	Dash	mm	inch	mm	inch	bar	psi	bar	psi	mm	inch	kg/m	lb/ft	NON-SKIVE
H3020S	31	-20	31,8	1.1/4	45,7	1.80	215	3100	860	12400	200	7.9	2,27	1.53	T7000
H3024S	38	-24	38,1	1.1/2	50,3	1.98	215	3100	860	12400	250	9.8	2,35	1.58	T7000
H3032S	51	-32	50,8	2	63,3	2.49	215	3100	860	12400	400	15.8	3,40	2.28	T7000

Refer to the latest Ryco Digital Crimp Tools for crimping parameters.

HOSES

ISOBARIC SPIRAL

H4000D

EXTRA ABRASION RESISTANT
FRAS

ISOBARIC SPIRAL HOSE

280 BAR / 4100 PSI

MILLION CYCLE

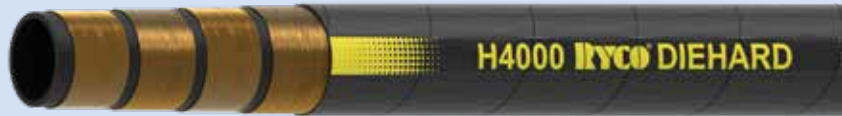

RECOMMENDED FOR:

High pressure hydraulic oil lines. Constant pressure (Isobaric) 280 bar / 4100 psi in all sizes. Small bend radius is an advantage in installations.

PERFORMANCE:

Meets or Exceeds the Performance Requirements of: EN 856 Type R12, EN 856 Type 45P (size DN25, -16), ISO 18752-DC, SAE 100R12.

TUBE:

Black, oil resistant synthetic rubber.

REINFORCEMENT:

Four (-06 to -24 size) and six (-32 size) alternating layers of spiralled high tensile steel wire.

COVER:

DIEHARD™ Black, oil and extra abrasion resistant synthetic rubber. Flame Resistant, Anti-Static (FRAS) & MSHA compliant. Highly visible layline branding for easy and permanent identification. No skiving required with T7000 Series Crimp Couplings.

FEATURES:

Tested to **1 million impulse cycles** at up to 1/2 SAE 100R12 Minimum Bend Radius. Constant pressure 280 bar / 4100 psi in all sizes for easy system design and hose selection. Small bend radius is an advantage in installations.

FRAS - FLAME RESISTANCE AND ANTI-STATIC:

DIEHARD™ complies with Flame Resistant and Electrical Resistance (Anti-Static) requirements of Australian Standard AS 2660 and Methods of Test AS 1180.10B and 13A. Meets Flame Resistant Designation "U.S. MSHA" of the US Department of Labor, Mine Safety and Health Administration.

TEMPERATURE RANGE:

-40°C to +121°C, (-40°F to +250°F).
For water, emulsions etc. see page 58.

WORKING PRESSURE:

Maximum working pressures are based on 4:1 safety factor (maximum working pressure to minimum burst pressure).

THIRD PARTY APPROVALS:

ABS, DNV-GL, LR, MED, USCG, GOST-R, BV, RINA and KR.

COUPLINGS:

NON-SKIVE ONE-PIECE CRIMP

T7000 Series (sizes -06 to -32).
Assembly Instructions pages 146.

H4000D - DIEHARD															
PART NO	HOSE SIZE	NOMINAL HOSE ID		NOMINAL HOSE OD		MAXIMUM WORKING PRESSURE		MINIMUM BURST PRESSURE		MINIMUM BEND RADIUS		AVERAGE WEIGHT		COUPLING SERIES ONE PIECE	
Hose	DN	Dash	mm	inch	mm	inch	bar	psi	bar	psi	mm	inch	kg/m	lb/ft	NON-SKIVE
H4006D	10	-06	9,5	3/8	19,3	0.76	280	4100	1120	16400	60	2.4	0,61	0.41	T7000
H4008D	12	-08	12,7	1/2	22,7	0.89	280	4100	1120	16400	90	3.5	0,78	0.52	T7000
H4010D	16	-10	15,9	5/8	24,9	0.98	280	4100	1120	16400	100	3.9	0,76	0.51	T7000
H4012D	19	-12	19,1	3/4	30,0	1.18	280	4100	1120	16400	120	4.7	1,13	0.76	T7000
H4016D	25	-16	25,4	1	36,9	1.45	280	4100	1120	16400	150	5.9	1,60	1.08	T7000
H4020D	31	-20	31,8	1.1/4	44,0	1.73	280	4100	1120	16400	210	8.3	2,07	1.39	T7000
H4024D	38	-24	38,1	1.1/2	50,8	2.00	280	4100	1120	16400	330	13.0	2,65	1.78	T7000
H4032D	51	-32	50,8	2	66,4	2.61	280	4100	1120	16400	400	15.8	4,73	3.18	T7000

Refer to the latest Ryco Digital Crimp Tools for crimping parameters.

H4000S

EXTREMELY ABRASION RESISTANT
MSHA
ISOBARIC SPIRAL HOSE
280 BAR / 4100 PSI
MILLION CYCLE



RECOMMENDED FOR:

High pressure hydraulic oil lines. Constant pressure (Isobaric) 280 bar / 4100 psi in all sizes. Small bend radius is an advantage in installations.

PERFORMANCE:

Meets or Exceeds the Performance Requirements of: EN 856 Type R12, EN 856 Type 4SP (size DN25, -16), ISO 18752-DC, SAE 100R12.

TUBE:

Black, oil resistant synthetic rubber.

REINFORCEMENT:

Four (-06 to -24 size) and six (-32 size) alternating layers of spiralled high tensile steel wire.

COVER:

SLIDER Black, oil and extremely abrasion resistant synthetic rubber sheathed with a layer of extremely abrasion resistant polyethylene. Flame Resistant, MSHA compliant. Highly visible layline branding for easy and permanent identification. No skiving required with T7000 Series Crimp Couplings.

FEATURES:

Tested to **1 million impulse cycles** at up to 1/2 SAE 100R12 Minimum Bend Radius. Constant pressure 280 bar / 4100 psi in all sizes for easy system design and hose selection. Small bend radius is an advantage in installations.

MSHA - FLAME RESISTANCE:

SLIDER complies with Flame Resistant requirements of Australian Standard AS 2660 and Methods of Test AS 1180.10B. Meets Flame Resistant Designation "U.S. MSHA" of the US Department of Labor, Mine Safety and Health Administration.

TEMPERATURE RANGE:

-40°C to +121°C, (-40°F to +250°F)
 For water, emulsions etc. see page 58.

WORKING PRESSURE:

Maximum working pressures are based on 4:1 safety factor (maximum working pressure to minimum burst pressure).

THIRD PARTY APPROVALS:

ABS, DNV-GL, LR, MED, USCG, GOST-R, BV, RINA and KR.

COUPLINGS:

NON-SKIVE ONE-PIECE CRIMP

T7000 Series (sizes -06 to -32).
 Assembly Instructions pages 146.

H4000S - SLIDER															
PART NO	HOSE SIZE	NOMINAL HOSE ID		NOMINAL HOSE OD		MAXIMUM WORKING PRESSURE		MINIMUM BURST PRESSURE		MINIMUM BEND RADIUS		AVERAGE WEIGHT		COUPLING SERIES ONE PIECE	
Hose	DN	Dash	mm	inch	mm	inch	bar	psi	bar	psi	mm	inch	kg/m	lb/ft	NON-SKIVE
H4006S	10	-06	9,5	3/8	19,3	0.76	280	4100	1120	16400	60	2.4	0,61	0.41	T7000
H4008S	12	-08	12,7	1/2	22,7	0.89	280	4100	1120	16400	90	3.5	0,78	0.52	T7000
H4010S	16	-10	15,9	5/8	24,9	0.98	280	4100	1120	16400	100	3.9	0,76	0.51	T7000
H4012S	19	-12	19,1	3/4	30,0	1.18	280	4100	1120	16400	120	4.7	1,13	0.76	T7000
H4016S	25	-16	25,4	1	36,9	1.45	280	4100	1120	16400	150	5.9	1,60	1.08	T7000
H4020S	31	-20	31,8	1.1/4	44,0	1.73	280	4100	1120	16400	210	8.3	2,07	1.39	T7000
H4024S	38	-24	38,1	1.1/2	50,8	2.00	280	4100	1120	16400	330	13.0	2,65	1.78	T7000
H4032S	51	-32	50,8	2	66,4	2.61	280	4100	1120	16400	400	15.8	4,73	3.18	T7000

Refer to the latest Ryco Digital Crimp Tools for crimping parameters.

HOSES

ISOBARIC SPIRAL

H5000C

LOW TEMPERATURE
ISOBARIC SPIRAL HOSE
350 BAR / 5100 PSI



RECOMMENDED FOR:

Very high pressure hydraulic oil lines in application where low temperature environmental conditions exist. Constant pressure (Isobaric) 350 bar / 5100 psi in all sizes. Small bend radius is an advantage in installations.

PERFORMANCE:

Meets or Exceeds the Performance Requirements of: EN 856 Type R13, ISO 18752-CC, SAE100R13.

TUBE:

Black, oil resistant synthetic rubber.

REINFORCEMENT:

Four (-12 to -20 size) and six (-32 size) alternating layers of spiralled high tensile steel wire.

COVER:

Black, oil and abrasion resistant synthetic rubber.

FEATURES:

Low temperature hose (-60°C/-76°F). Constant pressure 350 bar / 5100 psi in all sizes for easy system design and hose selection.

Small bend radius is an advantage in installations.

TEMPERATURE RANGE:

-60°C to +100°C (-76°F to +212°F).

WORKING PRESSURE:

Maximum working pressures are based on 4:1 safety factor (maximum working pressure to minimum burst pressure).

THIRD PARTY APPROVALS:

ABS, DNV-GL, LR, MED, USCG, GOST-R, BV, RINA and KR.

COUPLINGS:

NON-SKIVE ONE-PIECE CRIMP

T7000 Series (sizes -12 to -20).

Assembly Instructions pages 146.

H5000C - ICEBREAKER															
PART NO	HOSE SIZE	NOMINAL HOSE ID		NOMINAL HOSE OD		MAXIMUM WORKING PRESSURE		MINIMUM BURST PRESSURE		MINIMUM BEND RADIUS		AVERAGE WEIGHT		COUPLING SERIES ONE PIECE	
Hose	DN	Dash	mm	inch	mm	inch	bar	psi	bar	psi	mm	inch	kg/m	lb/ft	NON-SKIVE
H5012C	19	-12	19,1	3/4	29,6	1.17	350	5100	1400	20400	120	4.7	1,21	0.81	T7000
H5016C	25	-16	25,4	1	36,8	1.45	350	5100	1400	20400	150	5.9	1,72	1.16	T7000
H5020C	31	-20	31,8	1.1/4	45,0	1.77	350	5100	1400	20400	210	8.3	2,42	1.63	T7000
H5024C	38	-24	38,1	1.1/2	52,7	2.07	350	5100	1400	20400	330	13	3,44	2.31	T7000

Refer to the latest Ryco Digital Crimp Tools for crimping parameters.

H5000D

EXTRA ABRASION RESISTANT FRAS
ISOBARIC SPIRAL HOSE
350 BAR / 5100 PSI
MILLION CYCLE

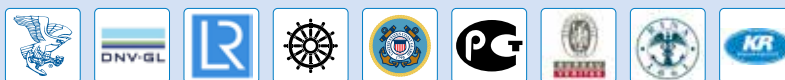

INTRODUCTION

HOSES

TECHNICAL

RECOMMENDED FOR:

Very high pressure hydraulic oil lines. Constant pressure (isobaric) 350 bar / 5100 psi in all sizes. Small bend radius is an advantage in installations.

PERFORMANCE:

Meets or Exceeds the Performance Requirements of: EN 856 Type R13, ISO 18752-CC, SAE 100R13.

TUBE:

Black, oil resistant synthetic rubber.

REINFORCEMENT:

Four (-06 to -20 size) and six (-24 to -32 size) alternating layers of spiralled high tensile steel wire.

COVER:

DIEHARD™ Black, oil and extra abrasion resistant synthetic rubber. Flame Resistant, Anti-Static (FRAS) & MSHA compliant. Highly visible layline branding for easy and permanent identification. No skiving required with T6000 & T7000 Series Crimp Couplings.

FEATURES:

Tested to **1 million impulse cycles** at up to 1/2 SAE 100R13 Minimum Bend Radius. Constant pressure 350 bar / 5100 psi in all sizes for easy system design and hose selection. Small bend radius is an advantage in installations.

FRAS - FLAME RESISTANCE AND ANTI-STATIC:

DIEHARD™ complies with Flame Resistant and Electrical Resistance (Anti-Static) requirements of Australian Standard AS 2660 and Methods of Test AS 1180.10B and 13A. Meets Flame Resistant Designation "U.S. MSHA" of the US Department of Labor, Mine Safety and Health Administration.

TEMPERATURE RANGE:

-40°C to +121°C, (-40°F to +250°F.)
 For water, emulsions etc. see page 58.

WORKING PRESSURE:

Maximum working pressures are based on 4:1 safety factor (maximum working pressure to minimum burst pressure).

THIRD PARTY APPROVALS:

ABS, DNV-GL, LR, MED, USCG, GOST-R, BV, RINA and KR.

COUPLINGS:

NON-SKIVE ONE-PIECE CRIMP

T7000 Series (sizes -06 to -24).
T6000 Series (size -12 to -32).
 Assembly Instructions pages 146.

H5000D - DIEHARD															
PART NO	HOSE SIZE	NOMINAL HOSE ID		NOMINAL HOSE OD		MAXIMUM WORKING PRESSURE		MINIMUM BURST PRESSURE		MINIMUM BEND RADIUS		AVERAGE WEIGHT		COUPLING SERIES ONE PIECE	
Hose	DN	Dash	mm	inch	mm	inch	bar	psi	bar	psi	mm	inch	kg/m	lb/ft	NON-SKIVE
H5006D	10	-06	9,5	3/8	19,3	0.76	350	5100	1400	20400	60	2.4	0,61	0.41	T7000
H5008D	12	-08	12,7	1/2	22,7	0.89	350	5100	1400	20400	90	3.5	0,78	0.52	T7000
H5010D	16	-10	15,9	5/8	26,2	1.03	350	5100	1400	20400	100	3.9	0,98	0.66	T7000
H5012D	19	-12	19,1	3/4	29,6	1.17	350	5100	1400	20400	120	4.7	1,21	0.81	T6000 T7000
H5016D	25	-16	25,4	1	36,8	1.45	350	5100	1400	20400	150	5.9	1,72	1.16	T6000 T7000
H5020D	31	-20	31,8	1.1/4	45,0	1.77	350	5100	1400	20400	210	8.3	2,42	1.63	T6000 T7000
H5024D	38	-24	38,1	1.1/2	52,7	2.07	350	5100	1400	20400	330	13.0	3,44	2.31	T6000 T7000
H5032D	51	-32	50,8	2	67,5	2.66	350	5100	1400	20400	400	15.8	5,40	3.63	T6000

Refer to the latest Ryco Digital Crimp Tools for crimping parameters.

HOSES

ISOBARIC SPIRAL

H5000S

EXTREMELY ABRASION RESISTANT

MSHA

ISOBARIC SPIRAL HOSE

350 BAR / 5100 PSI

MILLION CYCLE

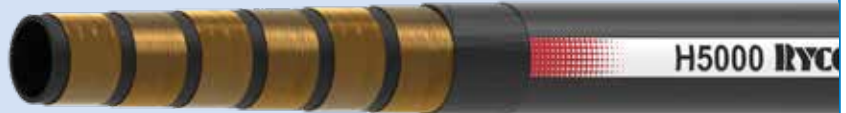

RECOMMENDED FOR:

Very high pressure hydraulic oil lines. Constant pressure (Isobaric) 350 bar / 5100 psi in all sizes. Small bend radius is an advantage in installations.

PERFORMANCE:

Meets or Exceeds the Performance Requirements of: EN 856 Type R13, ISO 18752-CC, SAE 100R13.

TUBE:

Black, oil resistant synthetic rubber.

REINFORCEMENT:

Four (-06 to -20 size) and six (-24 to -32 size) alternating layers of spiralled high tensile steel wire.

COVER:

SLIDER Black, oil and extremely abrasion resistant synthetic rubber sheathed with a layer of extremely abrasion resistant polyethylene. Flame Resistant, MSHA compliant. Highly visible layline branding for easy and permanent identification. No skiving required with T6000 & T7000 Series Crimp Couplings.

FEATURES:

Tested to **1 million impulse cycles** at up to 1/2 SAE 100R13 Minimum Bend Radius. Constant pressure 350 bar / 5100 psi in all sizes for easy system design and hose selection. Small bend radius is an advantage in installations.

MSHA - FLAME RESISTANCE:

SLIDER complies with Flame Resistant requirements of Australian Standard AS 2660 and Methods of Test AS 1180.10B. Meets Flame Resistant Designation "U.S. MSHA" of the US Department of Labor, Mine Safety and Health Administration.

TEMPERATURE RANGE:

-40°C to +121°C, (-40°F to +250°F.)
For water, emulsions etc. see page 58.

WORKING PRESSURE:

Maximum working pressures are based on 4:1 safety factor (maximum working pressure to minimum burst pressure).

THIRD PARTY APPROVALS:

ABS, DNV-GL, LR, MED, USCG, GOST-R, BV, RINA and KR.

COUPLINGS:

NON-SKIVE ONE-PIECE CRIMP

T7000 Series (sizes -06 to -24).

T6000 Series (size -12 to -32).

Assembly Instructions pages 146.

H5000S - SLIDER																
PART NO	HOSE SIZE	NOMINAL HOSE ID		NOMINAL HOSE OD		MAXIMUM WORKING PRESSURE		MINIMUM BURST PRESSURE		MINIMUM BEND RADIUS		AVERAGE WEIGHT		COUPLING SERIES ONE PIECE		
Hose	DN	Dash	mm	inch	mm	inch	bar	psi	bar	psi	mm	inch	kg/m	lb/ft	NON-SKIVE	
H5006S	10	-06	9,5	3/8	19,3	0.76	350	5100	1400	20400	60	2.4	0,61	0.41		T7000
H5008S	12	-08	12,7	1/2	22,7	0.89	350	5100	1400	20400	90	3.5	0,78	0.52		T7000
H5010S	16	-10	15,9	5/8	26,2	1.03	350	5100	1400	20400	100	3.9	0,98	0.66		T7000
H5012S	19	-12	19,1	3/4	29,6	1.17	350	5100	1400	20400	120	4.7	1,21	0.81	T6000	T7000
H5016S	25	-16	25,4	1	36,8	1.45	350	5100	1400	20400	150	5.9	1,72	1.16	T6000	T7000
H5020S	31	-20	31,8	1.1/4	45,0	1.77	350	5100	1400	20400	210	8.3	2,42	1.63	T6000	T7000
H5024S	38	-24	38,1	1.1/2	52,7	2.07	350	5100	1400	20400	330	13.0	3,44	2.31	T6000	T7000
H5032S	51	-32	50,8	2	67,5	2.66	350	5100	1400	20400	400	15.8	5,40	3.63	T6000	

Refer to the latest Ryco Digital Crimp Tools for crimping parameters.

H6000D

**EXTRA ABRASION RESISTANT
FRAS
ISOBARIC SPIRAL HOSE
420 BAR / 6100 PSI
MILLION CYCLE**



RECOMMENDED FOR:

Extremely high pressure hydraulic oil lines. Constant pressure (Isobaric) 420 bar / 6100 psi in all sizes. Small bend radius is an advantage in installations.

PERFORMANCE:

Meets or Exceeds the Performance Requirements of: EN 856 Type R15, ISO 18752-CC, SAE 100R15.

TUBE:

Black, oil resistant synthetic rubber.

REINFORCEMENT:

Four (-06 to -16 size), six (-20 to -24 size) and eight (-32 size) alternating layers of spiralled high tensile steel wire.

COVER:

DIEHARD™ Black, oil and extra abrasion resistant synthetic rubber. Flame Resistant, Anti-Static (FRAS) & MSHA compliant. Highly visible layline branding for easy and permanent identification. No skiving required with T6000 and T7000 Series Crimp Couplings.

FEATURES:

Tested to **1 million impulse cycles** at up to 1/2 SAE 100R15 Minimum Bend Radius. **World First:** World's first 2" (-32) hose tested to 1 million impulse cycles at 400mm (15.8") Minimum Bend Radius. Constant pressure 420 bar / 6100 psi in all sizes for easy system design and hose selection. Small bend radius is an advantage in installations.

FRAS - FLAME RESISTANCE AND ANTI-STATIC:

DIEHARD™ complies with Flame Resistant and Electrical Resistance (Anti-Static) requirements of Australian Standard AS 2660 and Methods of Test AS 1180.10B and 13A. Meets Flame Resistant Designation "U.S. MSHA" of the US Department of Labor, Mine Safety and Health Administration.

TEMPERATURE RANGE:

-40°C to +121°C (-40°F to +250°F).
For water, emulsions etc. see page 58.

WORKING PRESSURE:

Maximum working pressures are based on 4:1 safety factor (maximum working pressure to minimum burst pressure).

THIRD PARTY APPROVALS:

ABS, DNV-GL, LR, MED, USCG, GOST-R, BV, RINA and KR.

COUPLINGS:

NON-SKIVE ONE-PIECE CRIMP

T7000 Series (sizes -06 to -20).

T6000 Series (size -12 to -32).

Assembly Instructions pages 146.

H6000D - DIEHARD															
PART NO	HOSE SIZE	NOMINAL HOSE ID		NOMINAL HOSE OD		MAXIMUM WORKING PRESSURE		MINIMUM BURST PRESSURE		MINIMUM BEND RADIUS		AVERAGE WEIGHT		COUPLING SERIES ONE PIECE	
Hose	DN	Dash	mm	inch	mm	inch	bar	psi	bar	psi	mm	inch	kg/m	lb/ft	NON-SKIVE
H6006D	10	-06	9,5	3/8	19,3	0.76	420	6100	1680	24400	75	2.9	0,61	0.41	T7000
H6008D	12	-08	12,7	1/2	22,7	0.89	420	6100	1680	24400	100	3.9	0,78	0.52	T7000
H6010D	16	-10	15,9	5/8	26,2	1.03	420	6100	1680	24400	110	4.3	1,00	0.67	T7000
H6012D	19	-12	19,1	3/4	30,6	1.20	420	6100	1680	24400	115	4.5	1,38	0.93	T6000 T7000
H6016D	25	-16	25,4	1	37,5	1.48	420	6100	1680	24400	165	6.5	1,99	1.34	T6000 T7000
H6020D	31	-20	31,8	1.1/4	46,4	1.83	420	6100	1680	24400	220	8.7	2,97	2.00	T6000 T7000
H6024D	38	-24	38,1	1.1/2	53,1	2.09	420	6100	1680	24400	350	13.8	3,81	2.56	T6000
H6032D	51	-32	50,8	2	71,5	2.81	420	6100	1680	24400	400	15.8	7,10	4.77	T6000

Refer to the latest Ryco Digital Crimp Tools for crimping parameters.

HOSES

ISOBARIC SPIRAL

H6000S

EXTREMELY ABRASION RESISTANT

MSHA

ISOBARIC SPIRAL HOSE

420 BAR / 6100 PSI

MILLION CYCLE



RECOMMENDED FOR:

Extremely high pressure hydraulic oil lines. Constant pressure (isobaric) 420 bar / 6100 psi in all sizes. Small bend radius is an advantage in installations.

PERFORMANCE:

Meets or Exceeds the Performance Requirements of: ISO 3862 Type R15, ISO 18752-CC, SAE 100R15.

TUBE:

Black, oil resistant synthetic rubber.

REINFORCEMENT:

Four (-06 to -16 size), six (-20 to -24 size) and eight (-32 size) alternating layers of spiralled high tensile steel wire.

COVER:

SLIDER Black, oil and extremely abrasion resistant synthetic rubber sheathed with a layer of extremely abrasion resistant polyethylene. Flame Resistant, MSHA compliant. Highly visible layline branding for easy and permanent identification. No skiving required with T6000 and T7000 Series Crimp Couplings.

FEATURES:

Tested to **1 million impulse cycles** at up to 1/2 SAE 100R15 Minimum Bend Radius. **World First:** World's first 2" (-32) hose tested to 1 million impulse cycles at 400mm (15.8") Minimum Bend Radius. Constant pressure 420 bar / 6100 psi in all sizes for easy system design and hose selection. Small bend radius is an advantage in installations.

MSHA - FLAME RESISTANCE:

SLIDER complies with Flame Resistant requirements of Australian Standard AS 2660 and Methods of Test AS 1180.10B. Meets Flame Resistant Designation "U.S. MSHA" of the US Department of Labor, Mine Safety and Health Administration.

TEMPERATURE RANGE:

-40°C to +121°C (-40°F to +250°F).
For water, emulsions etc. see page 58.

WORKING PRESSURE:

Maximum working pressures are based on 4:1 safety factor (maximum working pressure to minimum burst pressure).

THIRD PARTY APPROVALS:

ABS, DNV-GL, LR, MED, USCG, GOST-R, BV, RINA and KR.

COUPLINGS:

NON-SKIVE ONE-PIECE CRIMP

T7000 Series (sizes -06 to -20).

T6000 Series (size -12 to -32).

Assembly Instructions pages 146.

H6000S - SLIDER															
PART NO	HOSE SIZE	NOMINAL HOSE ID		NOMINAL HOSE OD		MAXIMUM WORKING PRESSURE		MINIMUM BURST PRESSURE		MINIMUM BEND RADIUS		AVERAGE WEIGHT		COUPLING SERIES ONE PIECE	
Hose	DN	Dash	mm	inch	mm	inch	bar	psi	bar	psi	mm	inch	kg/m	lb/ft	NON-SKIVE
H6006S	10	-06	9,5	3/8	19,3	0.76	420	6100	1680	24400	75	2.9	0,61	0.41	T7000
H6008S	12	-08	12,7	1/2	22,7	0.89	420	6100	1680	24400	100	3.9	0,78	0.52	T7000
H6010S	16	-10	15,9	5/8	26,2	1.03	420	6100	1680	24400	110	4.3	1,00	0.67	T7000
H6012S	19	-12	19,1	3/4	30,6	1.20	420	6100	1680	24400	115	4.5	1,38	0.93	T6000 T7000
H6016S	25	-16	25,4	1	37,5	1.48	420	6100	1680	24400	165	6.5	1,99	1.34	T6000 T7000
H6020S	31	-20	31,8	1.1/4	46,4	1.83	420	6100	1680	24400	220	8.7	2,97	2.00	T6000 T7000
H6024S	38	-24	38,1	1.1/2	53,1	2.09	420	6100	1680	24400	350	13.8	3,81	2.56	T6000
H6032S	51	-32	50,8	2	71,5	2.81	420	6100	1680	24400	400	15.8	7,10	4.77	T6000

Refer to the latest Ryco Digital Crimp Tools for crimping parameters.

C6000D

**ULTRA FLEXIBLE
EXTRA ABRASION RESISTANT
FRAS
ISOBARIC SPIRAL HOSE
420 BAR / 6100 PSI
MILLION CYCLE**



INTRODUCTION

HOSES

TECHNICAL

RECOMMENDED FOR:

Ultra flexibility and small bend radius provides easy installation in compact environments.
Extremely high pressure hydraulic oil lines.
Constant pressure (Isobaric) 420 bar / 6100 psi in all sizes.

PERFORMANCE:

Meets or Exceeds the Performance Requirements of: ISO 18752-CC, SAE 100R15.

TUBE:

Black, oil resistant synthetic rubber.

REINFORCEMENT:

Four alternating layers of spiralled high tensile steel wire.

COVER:

DIEHARD™ Black, oil and extra abrasion resistant synthetic rubber. Flame Resistant, Anti-Static (FRAS) & MSHA compliant. Highly visible layline branding for easy and permanent identification. No skiving required with T7000 Series Crimp Couplings.

FEATURES:

Ultra flexibility combined with a small bend radius reduces effort during assembly and installations. Tested to **1 million impulse cycles** at up to 1/2 SAE 100R15 Minimum Bend Radius. Constant pressure 420 bar / 6100 psi in all sizes for easy system design and hose selection.

FRAS - FLAME RESISTANCE AND ANTI-STATIC:

DIEHARD™ complies with Flame Resistant and Electrical Resistance (Anti-Static) requirements of Australian Standard AS 2660 and Methods of Test AS 1180.10B and 13A. Meets Flame Resistant Designation "U.S. MSHA" of the US Department of Labor, Mine Safety and Health Administration.

TEMPERATURE RANGE:

-40°C to +121°C (-40°F to +250°F).

WORKING PRESSURE:

Maximum working pressures are based on 4:1 safety factor (maximum working pressure to minimum burst pressure).

COUPLINGS:

NON-SKIVE ONE-PIECE CRIMP

T7000 Series (sizes -12 to -16).
Assembly Instructions pages 146.

C6000D - DIEHARD															
PART NO	HOSE SIZE	NOMINAL HOSE ID		NOMINAL HOSE OD		MAXIMUM WORKING PRESSURE		MINIMUM BURST PRESSURE		MINIMUM BEND RADIUS		AVERAGE WEIGHT		COUPLING SERIES ONE PIECE	
Hose	DN	Dash	mm	inch	mm	inch	bar	psi	bar	psi	mm	inch	kg/m	lb/ft	NON-SKIVE
C6012D	19	-12	19,1	3/4	28,5	1.12	420	6100	1680	24400	115	4.5	1,15	0.77	T7000
C6016D	25	-16	25,4	1	35,8	1.41	420	6100	1680	24400	165	6.5	1,75	1.17	T7000

Refer to the latest Ryco Digital Crimp Tools for crimping parameters.

HOSES

ISOBARIC SPIRAL

C6000S

ULTRA FLEXIBLE
EXTREMELY ABRASION RESISTANT
ISOBARIC SPIRAL HOSE
420 BAR / 6100 PSI
MILLION CYCLE



RECOMMENDED FOR:

Ultra flexibility and small bend radius provides easy installation in compact environments.
Extremely high pressure hydraulic oil lines.
Constant pressure (Isobaric) 420 bar / 6100 psi in all sizes.

PERFORMANCE:

Meets or Exceeds the Performance Requirements of:
ISO 18752-CC, SAE 100R15.

TUBE:

Black, oil resistant synthetic rubber.

REINFORCEMENT:

Four alternating layers of spiralled high tensile steel wire.

COVER:

SLIDER Black, oil and extremely abrasion resistant synthetic rubber sheathed with a layer of extremely abrasion resistant polyethylene. Flame Resistant, MSHA compliant. Highly visible layline branding for easy and permanent identification. No skiving required with T7000 Series Crimp Couplings.

FEATURES:

Ultra flexibility combined with a small bend radius reduces effort during assembly and installations. Tested to **1 million impulse cycles** at up to 1/2 SAE 100R15 Minimum Bend Radius. Constant pressure 420 bar / 6100 psi in all sizes for easy system design and hose selection.

MSHA - FLAME RESISTANCE:

SLIDER complies with Flame Resistant requirements of Australian Standard AS 2660 and Methods of Test AS 1180.10B. Meets Flame Resistant Designation "U.S. MSHA" of the US Department of Labor, Mine Safety and Health Administration.

TEMPERATURE RANGE:

-40°C to +121°C (-40°F to +250°F).

WORKING PRESSURE:

Maximum working pressures are based on 4:1 safety factor (maximum working pressure to minimum burst pressure).

COUPLINGS:

NON-SKIVE ONE-PIECE CRIMP

T7000 Series (sizes -12 to -16).

Assembly Instructions pages 146.

C6000S - DIEHARD															
PART NO	HOSE SIZE	NOMINAL HOSE ID		NOMINAL HOSE OD		MAXIMUM WORKING PRESSURE		MINIMUM BURST PRESSURE		MINIMUM BEND RADIUS		AVERAGE WEIGHT		COUPLING SERIES ONE PIECE	
Hose	DN	Dash	mm	inch	mm	inch	bar	psi	bar	psi	mm	inch	kg/m	lb/ft	NON-SKIVE
C6012S	19	-12	19,1	3/4	28,5	1.12	420	6100	1680	24400	115	4.5	1,15	0.77	T7000
C6016S	25	-16	25,4	1	35,8	1.41	4.20	6100	1680	24400	165	6.5	1,75	1.17	T7000

Refer to the latest Ryco Digital Crimp Tools for crimping parameters.

DF1D

**EXTRA ABRASION RESISTANT
FRAS
COMPACT HOSE
ONE WIRE BRAID**



INTRODUCTION

HOSES

TECHNICAL

RECOMMENDED FOR:

High pressure hydraulic oil lines in applications where the outside cover of the hose is subjected to abrasion that may cause premature failure of standard hoses.

PERFORMANCE:

Meets or Exceeds the Performance Requirements of: EN 857 Type 1SC, ISO 11237 Type 1SC.

TUBE:

Black, oil resistant synthetic rubber.

REINFORCEMENT:

One braid of high tensile steel wire.

COVER:

DIEHARD™ Black, oil and extra abrasion resistant synthetic rubber. Flame Resistant, Anti-Static (FRAS) & MSHA compliant. Highly visible layline branding for easy and permanent identification. No skiving required with T2000 Series Crimp Couplings.

FEATURES:

The very high abrasion resistant properties of the cover, combined with the high working pressures and excellent impulse life, results in increased service life and minimises equipment downtime.

FRAS - FLAME RESISTANCE AND ANTI-STATIC:

DIEHARD™ complies with Flame Resistant and Electrical Resistance (Anti-Static) requirements of Australian Standard AS 2660 and Methods of Test AS 1180.10B and 13A. Meets Flame Resistant Designation "U.S MSHA" of the US Department of Labour, Mine Safety and Health Administration.

TEMPERATURE RANGE:

From -40°C to +100°C (-40°F to +212°F).

WORKING PRESSURE:

Maximum working pressures are based on 4:1 safety factor (maximum working pressure to minimum burst pressure).

THIRD PARTY APPROVALS:

ABS, DNV-GL, LR, MED, USCG, GOST-R, BV, RINA and KR.

COUPLINGS:

NON-SKIVE ONE-PIECE CRIMP

T2000 Series (sizes -04 to -16).
Assembly Instructions pages 146.

Not suitable for use with field attachable couplings.

DF1D - DIEHARD DINFLEX															
PART NO	HOSE SIZE	NOMINAL HOSE ID		NOMINAL HOSE OD		MAXIMUM WORKING PRESSURE		MINIMUM BURST PRESSURE		MINIMUM BEND RADIUS		AVERAGE WEIGHT		COUPLING SERIES ONE PIECE	
Hose	DN	Dash	mm	inch	mm	inch	bar	psi	bar	psi	mm	inch	kg/m	lb/ft	NON-SKIVE
DF14D	6	-04	6,6	1/4	12,2	0.48	225	3250	900	13000	50	2.0	0,20	0.13	T2000
DF15D	8	-05	8,2	5/16	13,9	0.55	215	3100	860	12400	55	2.2	0,22	0.15	T2000
DF16D	10	-06	9,8	3/8	15,6	0.61	180	2600	720	10400	65	2.6	0,26	0.17	T2000
DF18D	12	-08	13,0	1/2	19,0	0.75	160	2300	640	9200	85	3.3	0,33	0.22	T2000
DF110D	16	-10	16,2	5/8	22,2	0.80	130	1900	520	7600	100	3.9	0,44	0.30	T2000
DF112D	19	-12	19,1	3/4	25,6	1.01	105	1500	420	6000	115	4.5	0,50	0.34	T2000
DF116D	25	-16	25,4	1	33,6	1.32	90	1280	360	5120	150	5.9	0,75	0.50	T2000

Refer to the latest Ryco Digital Crimp Tools for crimping parameters.

HOSES

BRAID

DF2D

EXTRA ABRASION RESISTANT
FRAS
COMPACT HOSE
TWO WIRE BRAID



RECOMMENDED FOR:

High pressure hydraulic oil lines in applications where the outside cover of the hose is subjected to abrasion that may cause premature failure of standard hoses. Ideal for high pressure use that requires a compact outside diameter and smaller bend radius than some other two wire braid hoses.

PERFORMANCE:

Meets or Exceeds the Performance Requirements of: EN 857 Type 2SC, ISO 11237 Type 2SC, SAE 100R16. (-20 size SAE 100R16 only).

TUBE:

Black, oil resistant synthetic rubber.

REINFORCEMENT:

Two braids of high tensile steel wire.

COVER:

DIEHARD™ Black, oil and extra abrasion resistant synthetic rubber. Flame Resistant, Anti-Static (FRAS) & MSHA compliant. Highly visible layline branding for easy and permanent identification. No skiving required with T2000 Series Crimp Couplings.

FEATURES:

The very high abrasion resistant properties of the cover, combined with the high working pressures and excellent impulse life, results in increased service life and minimises equipment downtime.

FRAS - FLAME RESISTANCE AND ANTI-STATIC:

DIEHARD™ complies with Flame Resistant and Electrical Resistance (Anti-Static) requirements of Australian Standard AS 2660 and Methods of Test AS 1180.10B and 13A. Meets Flame Resistant Designation "U.S MSHA" of the US Department of Labour, Mine Safety and Health Administration.

TEMPERATURE RANGE:

From -40°C to +100°C (-40°F to +212°F).

WORKING PRESSURE:

Maximum working pressures are based on 4:1 safety factor (maximum working pressure to minimum burst pressure).

THIRD PARTY APPROVALS:

ABS, DNV-GL, LR, MED, USCG, GOST-R, BV, RINA and KR.

COUPLINGS:

NON-SKIVE ONE-PIECE CRIMP

T2000 Series (sizes -04 to -20).

Assembly Instructions pages 146.

Not suitable for use with field attachable couplings.

DF2D - DIEHARD DINFLEX															
PART NO	HOSE SIZE	NOMINAL HOSE ID		NOMINAL HOSE OD		MAXIMUM WORKING PRESSURE		MINIMUM BURST PRESSURE		MINIMUM BEND RADIUS		AVERAGE WEIGHT		COUPLING SERIES ONE PIECE	
Hose	DN	Dash	mm	inch	mm	inch	bar	psi	bar	psi	mm	inch	kg/m	lb/ft	NON-SKIVE
DF24D	6	-04	6,6	1/4	13,4	0.53	420	6100	1680	24000	50	2.0	0,28	0.19	T2000
DF25D	8	-05	8,2	5/16	14,9	0.59	350	5100	1400	20400	55	2.2	0,41	0.27	T2000
DF26D	10	-06	9,8	3/8	17,3	0.68	350	5100	1400	20400	65	2.6	0,43	0.29	T2000
DF28D	12	-08	13,0	1/2	20,3	0.80	295	4250	1180	17000	90	3.6	0,51	0.34	T2000
DF210D	16	-10	16,2	5/8	23,6	0.93	250	3625	1000	14500	100	3.9	0,63	0.42	T2000
DF212D	19	-12	19,1	3/4	27,6	1.09	215	3100	860	12400	120	4.7	0,81	0.55	T2000
DF216D	25	-16	25,4	1	35,8	1.40	170	2400	668	9700	150	5.9	1,10	0.74	T2000
DF220D*	31	-20	31,8	1.1/4	41,3	1.63	140	2000	560	8000	150	5.9	1,39	0.93	T2000

* DF220D Minimum Bend Radius is smaller than that of SAE 100R16 by approximately 30%
Refer to the latest Ryco Digital Crimp Tools for crimping parameters.

DK1D

EXTRA ABRASION RESISTANT
EXTRA HIGH PRESSURE
FRAS
COMPACT ONE WIRE BRAID HOSE



INTRODUCTION

HOSES

TECHNICAL

RECOMMENDED FOR:

Extra high pressure hydraulic oil lines in applications where the hose cover is subjected to abrasion. Compact dimensions and small bend radius are advantages in installations where space is limited.

PERFORMANCE:

Exceeds the Performance Requirements of:
EN 857 Type 1SC, ISO 11237 Type 1SC.

CONSTRUCTION:

Ryco Proprietary DK1D design.

TUBE:

Black, oil resistant synthetic rubber.

REINFORCEMENT:

One braid of high tensile steel wire.

COVER:

DIEHARD™ Black, oil, ozone and extra abrasion resistant synthetic rubber. Flame Resistant, Anti-Static (FRAS) & MSHA compliant. Highly visible layline branding for easy and permanent identification. No skiving required with T2000 Series Crimp Couplings.

FEATURES:

The very high abrasion resistant properties of the cover, combined with the extra high working pressures and excellent impulse life, results in increased service life and minimises equipment downtime. Compact dimensions and small bend radius are advantages in installations where space is limited.

FRAS - FLAME RESISTANCE AND ANTI-STATIC:

DIEHARD™ complies with Flame Resistant and Electrical Resistance (Anti-Static) requirements of Australian Standard AS 2660 and Methods of Test AS 1180.10B and 13A, and requirements of ISO 6805 when tested in accordance with ISO 8030 and ISO 8031. Meets Flame Resistant Designation "U.S. MSHA" of the US Department of Labour, Mine Safety and Health Administration.

TEMPERATURE RANGE:

From -40°C to +100°C (-40°F to +212°F).

WORKING PRESSURE:

Maximum working pressures are based on 4:1 safety factor (maximum working pressure to minimum burst pressure).

COUPLINGS:

NON-SKIVE ONE-PIECE CRIMP

T2000 Series (sizes -04 to -16).
Assembly Instructions pages 146.

Not suitable for use with field attachable couplings.

DK1D - DIEHARD															
PART NO	HOSE SIZE	NOMINAL HOSE ID		NOMINAL HOSE OD		MAXIMUM WORKING PRESSURE		MINIMUM BURST PRESSURE		MINIMUM BEND RADIUS		AVERAGE WEIGHT		COUPLING SERIES ONE PIECE	
Hose	DN	Dash	mm	inch	mm	inch	bar	psi	bar	psi	mm	inch	kg/m	lb/ft	NON-SKIVE
DK14D	6	-04	6,6	1/4	11,6	0.46	295	4280	1180	17120	40	1.6	0,16	0.11	T2000
DK15D	8	-05	8,5	5/16	13,4	0.53	250	3625	1000	14500	50	2.0	0,20	0.13	T2000
DK16D	10	-06	9,8	3/8	15,0	0.59	230	3330	920	13360	65	2.6	0,24	0.16	T2000
DK18D	12	-08	13,0	1/2	18,3	0.72	200	2900	800	11600	80	3.1	0,31	0.21	T2000
DK110D	16	-10	16,1	5/8	21,5	0.85	150	2175	600	8700	100	3,9	0,38	0.26	T2000
DK112D	19	-12	19,1	3/4	24,7	0.97	125	1815	500	7260	120	4.7	0,44	0.30	T2000
DK116D	25	-16	25,4	1	31,6	1.24	110	1600	440	6400	150	5,9	0,61	0.41	T2000
DK120D	31	-20	31,8	1.1/4	38,4	1.51	100	1450	400	5800	200	7.9	0,79	0.53	T2000

Refer to the latest Ryco Digital Crimp Tools for crimping parameters.

HOSES

BRAID

DK1E

EXTRA HIGH PRESSURE
COMPACT ONE WIRE BRAID HOSE



RECOMMENDED FOR:

Extra high pressure hydraulic oil lines in applications. Compact dimensions and small bend radius are advantages in installations where space is limited.

PERFORMANCE:

Exceeds the Performance Requirements of: EN 857 Type 1SC, ISO 11237 Type 1SC.

CONSTRUCTION:

Ryco Proprietary DK1E design.

TUBE:

Black, oil resistant synthetic rubber.

REINFORCEMENT:

One braid of high tensile steel wire.

COVER:

Black, oil resistant synthetic rubber. No skiving required with T2000 Series Crimp Couplings.

FEATURES:

The extra high working pressures and excellent impulse life, results in increased service life and minimises equipment downtime.

Compact dimensions and small bend radius are advantages in installations where space is limited.

TEMPERATURE RANGE:

From -40°C to +100°C (-40°F to +212°F).

WORKING PRESSURE:

Maximum working pressures are based on 4:1 safety factor (maximum working pressure to minimum burst pressure).

COUPLINGS:

NON-SKIVE ONE-PIECE CRIMP

T2000 Series (sizes -04 to -20).

Assembly Instructions pages 146.

Not suitable for use with field attachable couplings.

DK1E - ENERGY															
PART NO	HOSE SIZE	NOMINAL HOSE ID		NOMINAL HOSE OD		MAXIMUM WORKING PRESSURE		MINIMUM BURST PRESSURE		MINIMUM BEND RADIUS		AVERAGE WEIGHT		COUPLING SERIES ONE PIECE	
Hose	DN	Dash	mm	inch	mm	inch	bar	psi	bar	psi	mm	inch	kg/m	lb/ft	NON-SKIVE
DK14E	6	-04	6,6	1/4	11,6	0.46	295	4280	1180	17120	40	1.6	0,16	0.11	T2000
DK15E	8	-05	8,5	5/16	13,4	0.53	250	3625	1000	14500	50	2.0	0,20	0.13	T2000
DK16E	10	-06	9,8	3/8	15,0	0.59	230	3330	920	13360	65	2.6	0,24	0.16	T2000
DK18E	12	-08	13,0	1/2	18,3	0.72	200	2900	800	11600	80	3.1	0,31	0.21	T2000
DK110E	16	-10	16,1	5/8	21,5	0.85	150	2175	600	8700	100	3,9	0,38	0.26	T2000
DK112E	19	-12	19,1	3/4	24,7	0.97	125	1815	500	7260	120	4.7	0,44	0.30	T2000
DK116E	25	-16	25,4	1	31,6	1.24	110	1600	440	6400	150	5,9	0,61	0.41	T2000
DK120E	31	-20	31,8	1.1/4	38,4	1.51	100	1450	400	5800	200	7.9	0,79	0.53	T2000

Refer to the latest Ryco Digital Crimp Tools for crimping parameters.

DK1S

**EXTREMELY ABRASION RESISTANT
EXTRA HIGH PRESSURE
COMPACT ONE WIRE BRAID HOSE**



INTRODUCTION

HOSES

TECHNICAL

RECOMMENDED FOR:

Extra high pressure hydraulic oil lines in applications where the hose cover is subjected to abrasion. Compact dimensions and small bend radius are advantages in installations where space is limited.

PERFORMANCE:

Exceeds the Performance Requirements of: EN 857 Type 1SC, ISO 11237 Type 1SC.

CONSTRUCTION:

Ryco Proprietary DK1S design.

TUBE:

Black, oil resistant synthetic rubber.

REINFORCEMENT:

One braid of high tensile steel wire.

COVER:

SLIDER Black, oil and extremely abrasion resistant synthetic rubber sheathed with a layer of extremely abrasion resistant polyethylene. Flame Resistant, MSHA compliant. Highly visible layline branding for easy and permanent identification. No skiving required with T2000 Series Crimp Couplings.

FEATURES:

The extremely abrasion resistant properties of the cover, combined with the extra high working pressures and excellent impulse life, results in increased service life and minimises equipment downtime. Compact dimensions and small bend radius are advantages in installations where space is limited.

MSHA - FLAME RESISTANCE:

SLIDER meets Flame Resistant Designation "U.S. MSHA" of the US Department of Labor, Mine Safety and Health Administration.

TEMPERATURE RANGE:

From -40°C to +100°C (-40°F to +212°F).

WORKING PRESSURE:

Maximum working pressures are based on 4:1 safety factor (maximum working pressure to minimum burst pressure).

COUPLINGS:

NON-SKIVE ONE-PIECE CRIMP

T2000 Series (sizes -04 to -20).

Assembly Instructions pages 146.

Not suitable for use with field attachable couplings.

DK1S - SLIDER															
PART NO	HOSE SIZE		NOMINAL HOSE ID		NOMINAL HOSE OD		MAXIMUM WORKING PRESSURE		MINIMUM BURST PRESSURE		MINIMUM BEND RADIUS		AVERAGE WEIGHT		COUPLING SERIES ONE PIECE
Hose	DN	Dash	mm	inch	mm	inch	bar	psi	bar	psi	mm	inch	kg/m	lb/ft	NON-SKIVE
DK14S	6	-04	6,6	1/4	11,6	0.46	295	4280	1180	17120	40	1.6	0,16	0.11	T2000
DK15S	8	-05	8,5	5/16	13,4	0.53	250	3625	1000	14500	50	2.0	0,20	0.13	T2000
DK16S	10	-06	9,8	3/8	15,0	0.59	230	3330	920	13360	65	2.6	0,24	0.16	T2000
DK18S	12	-08	13,0	1/2	18,3	0.72	200	2900	800	11600	80	3.1	0,31	0.21	T2000
DK110S	16	-10	16,1	5/8	21,5	0.85	150	2175	600	8700	100	3,9	0,38	0.26	T2000
DK112S	19	-12	19,1	3/4	24,7	0.97	125	1815	500	7260	120	4.7	0,44	0.30	T2000
DK116S	25	-16	25,4	1	31,6	1.24	110	1600	440	6400	150	5,9	0,61	0.41	T2000
DK120S	31	-20	31,8	1.1/4	38,4	1.51	100	1450	400	5800	200	7.9	0,79	0.53	T2000

Refer to the latest Ryco Digital Crimp Tools for crimping parameters.

DK2D

**EXTRA ABRASION RESISTANT
EXTRA HIGH PRESSURE
FRAS
COMPACT TWO WIRE BRAID HOSE**



TESTED UP TO 1 MILLION CYCLES

RECOMMENDED FOR:

Extra high pressure hydraulic oil lines in applications where the hose cover is subjected to abrasion. Compact dimensions and small bend radius are advantages in installations where space is limited.

PERFORMANCE:

Exceeds the Performance Requirements of: EN 857 Type 2SC, ISO 6805 Type 1 & Type 2, ISO 6805 Type 4 (sizes -10 and above), ISO 11237 Type 2SC.

CONSTRUCTION:

Ryco Proprietary DK2D design.

TUBE:

Black, oil resistant synthetic rubber.

REINFORCEMENT:

Two braids of high tensile steel wire.

COVER:

DIEHARD™ Black, oil, ozone and extra abrasion resistant synthetic rubber. Flame Resistant, Anti-Static (FRAS) & MSHA compliant. Highly visible layline branding for easy and permanent identification. No skiving required with T2000 Series Crimp Couplings.

FEATURES:

The very high abrasion resistant properties of the cover, combined with the extra high working pressures and excellent impulse life, results in increased service life and minimises equipment downtime. Compact dimensions and small bend radius are advantages in installations where space is limited.

FRAS - FLAME RESISTANCE AND ANTI-STATIC:

DIEHARD™ complies with Flame Resistant and Electrical Resistance (Anti-Static) requirements of Australian Standard AS 2660 and Methods of Test AS 1180.10B and 13A, and requirements of ISO 6805 when tested in accordance with ISO 8030 and ISO 8031.

Meets Flame Resistant Designation "U.S MSHA" of the US Department of Labour, Mine Safety and Health Administration.

TEMPERATURE RANGE:

From -40°C to +100°C (-40°F to +212°F).

WORKING PRESSURE:

Maximum working pressures are based on 4:1 safety factor (maximum working pressure to minimum burst pressure).

COUPLINGS:

NON-SKIVE ONE-PIECE CRIMP

T2000 Series (sizes -04 to -06).

Assembly Instructions pages 146.

Not suitable for use with field attachable couplings.

DK2D - DIEHARD															
PART NO	HOSE SIZE		NOMINAL HOSE ID		NOMINAL HOSE OD		MAXIMUM WORKING PRESSURE		MINIMUM BURST PRESSURE		MINIMUM BEND RADIUS		AVERAGE WEIGHT		COUPLING SERIES ONE PIECE
Hose	DN	Dash	mm	inch	mm	inch	bar	psi	bar	psi	mm	inch	kg/m	lb/ft	NON-SKIVE
DK24D	6	-04	6,7	1/4	13,7	0.54	450	6525	1800	26100	45	1.8	0,30	0.20	T2000
DK25D	8	-05	8,2	5/16	14,8	0.60	420	6100	1680	24400	60	2.4	0,36	0.24	T2000
DK26D	10	-06	9,8	3/8	17,1	0.67	385	5590	1540	22360	70	2.8	0,41	0.27	T2000
DK28D	12	-08	13,0	1/2	20,3	0.80	350	5100	1380	20000	90	3.5	0,55	0.37	T2000
DK210D	16	-10	16,2	5/8	24,1	0.95	290	4210	1160	16840	130	5.1	0,69	0.46	T2000
DK212D	19	-12	19,3	3/4	27,8	1.09	280	4100	1120	16400	160	6.3	0,88	0.59	T2000
DK216D	25	-16	25,8	1	35,6	1.40	200	2900	800	11600	210	8.3	1,31	0.88	T2000
DK220D	31	-20	32,2	1.1/4	43,5	1.71	175	2540	700	10160	280	11.0	1,70	1.14	T2000

Refer to the latest Ryco Digital Crimp Tools for crimping parameters.

DK2E

**EXTRA HIGH PRESSURE
COMPACT TWO WIRE BRAID HOSE**



TESTED UP TO 1 MILLION CYCLES

INTRODUCTION

HOSES

TECHNICAL

RECOMMENDED FOR:

High pressure hydraulic oil lines. Ideal for high pressure use that requires a compact outside diameter and smaller bend radius than some other two wire braid hoses.

PERFORMANCE:

Exceeds the Performance Requirements of: EN 857 Type 2SC, ISO 6805 Type 1 & Type 2, ISO 6805 Type 4 (sizes -10 and above), ISO 11237 Type 2SC.

CONSTRUCTION: Ryco Proprietary DK2E design.

TUBE:

Black, oil resistant synthetic rubber.

REINFORCEMENT:

Two braids of high tensile steel wire.

COVER:

Black, oil resistant synthetic rubber. No skiving required with T2000 Series Crimp Couplings.

FEATURES:

The extra high working pressures and excellent impulse life, results in increased service life and minimises equipment downtime.

Compact dimensions and small bend radius are advantages in installations where space is limited.

TEMPERATURE RANGE:

From -40°C to +100°C (-40°F to +212°F).

WORKING PRESSURE:

Maximum working pressures are based on 4:1 safety factor (maximum working pressure to minimum burst pressure).

COUPLINGS:

NON-SKIVE ONE-PIECE CRIMP

T2000 Series (sizes -04 to -20).

Assembly Instructions pages 146.

Not suitable for use with field attachable couplings.

DK2E - ENERGY															
PART NO	HOSE SIZE	NOMINAL HOSE ID		NOMINAL HOSE OD		MAXIMUM WORKING PRESSURE		MINIMUM BURST PRESSURE		MINIMUM BEND RADIUS		AVERAGE WEIGHT		COUPLING SERIES ONE PIECE	
Hose	DN	Dash	mm	inch	mm	inch	bar	psi	bar	psi	mm	inch	kg/m	lb/ft	NON-SKIVE
DK24E	6	-04	6,7	1/4	13,7	0.54	450	6525	1800	26100	45	1.8	0,30	0.20	T2000
DK25E	8	-05	8,2	5/16	14,8	0.60	420	6100	1680	24400	60	2.4	0,36	0.24	T2000
DK26E	10	-06	9,8	3/8	17,1	0.67	385	5590	1540	22360	70	2.8	0,41	0.27	T2000
DK28E	12	-08	13,0	1/2	20,3	0.80	350	5100	1380	20000	90	3.5	0,55	0.37	T2000
DK210E	16	-10	16,2	5/8	24,1	0.95	290	4210	1160	16840	130	5.1	0,69	0.46	T2000
DK212E	19	-12	19,3	3/4	27,8	1.09	280	4100	1120	16400	160	6.3	0,88	0.59	T2000
DK216E	25	-16	25,8	1	35,6	1.40	200	2900	800	11600	210	8.3	1,31	0.88	T2000
DK220E	31	-20	32,2	1.1/4	43,5	1.71	175	2540	700	10160	280	11.0	1,70	1.14	T2000

Refer to the latest Ryco Digital Crimp Tools for crimping parameters.

HOSES

BRAID

DK2S

**EXTREMELY ABRASION RESISTANT
EXTRA HIGH PRESSURE
COMPACT TWO WIRE BRAID HOSE**



TESTED UP TO 1 MILLION CYCLES

RECOMMENDED FOR:

Extra high pressure hydraulic oil lines in applications where the hose cover is subjected to abrasion. Compact dimensions and small bend radius are advantages in installations where space is limited.

PERFORMANCE:

Exceeds the Performance Requirements of: EN 857 Type 2SC, ISO 6805 Type 1 & Type 2, ISO 6805 Type 4 (sizes -10 and above), ISO 11237 Type 2SC.

CONSTRUCTION:

Ryco Proprietary DK2S design.

TUBE:

Black, oil resistant synthetic rubber.

REINFORCEMENT:

Two braids of high tensile steel wire.

COVER:

SLIDER Black, oil and extremely abrasion resistant synthetic rubber sheathed with a layer of extremely abrasion resistant polyethylene. Flame Resistant, MSHA compliant. Highly visible layline branding for easy and permanent identification. No skiving required with T2000 Series Crimp Couplings.

FEATURES:

The extremely abrasion resistant properties of the cover, combined with the extra high working pressures and excellent impulse life, results in increased service life and minimises equipment downtime. Compact dimensions and small bend radius are advantages in installations where space is limited.

MSHA - FLAME RESISTANCE:

SLIDER complies with Flame Resistant requirements of Australian Standard AS 2660 and Methods of Test AS 1180.10B. Meets Flame Resistant Designation "U.S. MSHA" of the US Department of Labor, Mine Safety and Health Administration.

TEMPERATURE RANGE:

From -40°C to +100°C (-40°F to +212°F).

WORKING PRESSURE:

Maximum working pressures are based on 4:1 safety factor (maximum working pressure to minimum burst pressure).

COUPLINGS:

NON-SKIVE ONE-PIECE CRIMP

T2000 Series (sizes -04 to -20).

Assembly Instructions pages 146.

Not suitable for use with field attachable couplings.

DK2S - SLIDER															
PART NO	HOSE SIZE	NOMINAL HOSE ID		NOMINAL HOSE OD		MAXIMUM WORKING PRESSURE		MINIMUM BURST PRESSURE		MINIMUM BEND RADIUS		AVERAGE WEIGHT		COUPLING SERIES ONE PIECE	
Hose	DN	Dash	mm	inch	mm	inch	bar	psi	bar	psi	mm	inch	kg/m	lb/ft	NON-SKIVE
DK24S	6	-04	6,7	1/4	13,7	0.54	450	6525	1800	26100	45	1.8	0,30	0.20	T2000
DK25S	8	-05	8,2	5/16	14,8	0.60	420	6100	1680	24400	60	2.4	0,36	0.24	T2000
DK26S	10	-06	9,8	3/8	17,1	0.67	385	5590	1540	22360	70	2.8	0,41	0.27	T2000
DK28S	12	-08	13,0	1/2	20,3	0.80	350	5100	1380	20000	90	3.5	0,55	0.37	T2000
DK210S	16	-10	16,2	5/8	24,1	0.95	290	4210	1160	16840	130	5.1	0,69	0.46	T2000
DK212S	19	-12	19,3	3/4	27,8	1.09	280	4100	1120	16400	160	6.3	0,88	0.59	T2000
DK216S	25	-16	25,8	1	35,6	1.40	200	2900	800	11600	210	8.3	1,31	0.88	T2000
DK220S	31	-20	32,2	1.1/4	43,5	1.71	175	2540	700	10160	280	11.0	1,70	1.14	T2000

Refer to the latest Ryco Digital Crimp Tools for crimping parameters.



ENERGY EFFICIENT

ENERGY AND PERFORMANCE

EC1 & EC2

ENERGY COMPACT HOSE

E1 & E2

ENERGY HOSE

The agricultural equipment manufacturing and distribution industry has been the cornerstone of Ryco since our humble beginnings. Today, Original Equipment Manufacturer's rely on Ryco to create and supply specialised product that performs above the requirements of our ever increasing, challenging applications.

Agricultural equipment manufacturer's utilise and trust Ryco products in regional and international markets.

The demanding conditions in which these machines operate highlights the proven design features and product durability of Ryco Hydraulic Hose, Adaptors, Couplings, and Field Attachable fittings.

You will find Ryco products on cane harvesters, laser levellers, front end loaders and backhoes, timber harvesting equipment, ploughs, bailers, tractors (two through to eight wheel drive) and just about any other implement imaginable. Ryco gives cost effective returns to the farming community and suppliers.

ENERGY EFFICIENT

Ryco's E1 & E2 & Ryco EC1 & EC2 Hydraulic Hose provides you with superior operator comfort for improved working conditions and precise control for optimum machinery performance. With Ryco on the inside you get the consistent performance needed for maximum yields.

Ryco PERFORMANCE

Ryco's comprehensive testing and evaluation process guarantees you the performance and quality required to meet the demands of today's applications, by safely conveying fluids at high pressure.

Ryco ENERGY hose has performance of:

Ryco EC1

EN 857 Type 1SC & ISO 11237 Type 1SC .

Ryco EC2

EN 857 Type 2SC, ISO 11237 Type 2SC & SAE 100R16

Ryco E1

AS3791 100R1AT, DIN 20022-1SN, EN 853 Type 1SN, ISO 1436 Types R1AT & 1SN, SAE 100R1AT.

Ryco E2

AS3791 100R2AT, DIN 20022-2SN, EN 853 Type 2SN, ISO 1436 Types R2AT & 2SN, SAE 100R2AT.

WE HAVE YOU COVERED

Ryco ENERGY contains two braids of high tensile steel wire. The E2 & EC range of hoses is 1/4" to 1".

Ryco ENERGY hose cover is black, oil resistant synthetic rubber.

Ryco EC SERIES

Non-Skive One piece Couplings T2000.

Ryco E SERIES

Non-Skive One piece Couplings T2000 & T7000.

Field Attachable Non-Skive 6000 insert (L000 ferrule).

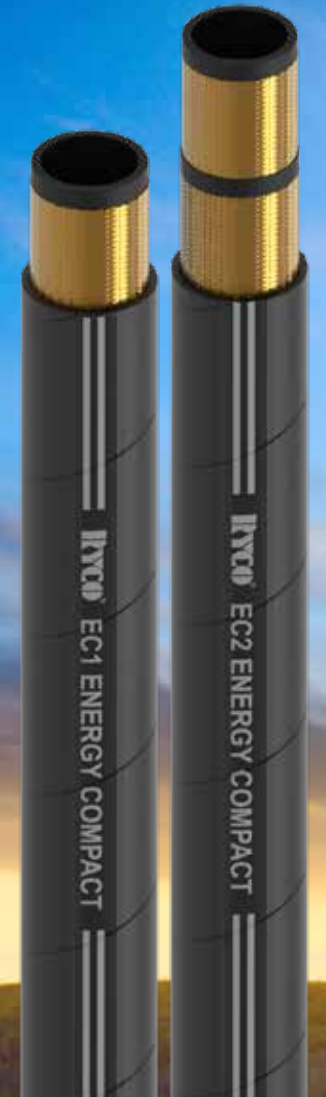

HOSES

BRAID

EC1

ENERGY COMPACT ONE WIRE BRAID HOSE



RECOMMENDED FOR:

High pressure hydraulic oil lines. Ideal for high pressure use that requires a more compact outside diameter than some other one wire braid hoses.

PERFORMANCE:

Meets or Exceeds the Performance Requirements of: EN 857 Type 1SC, ISO 11237 Type 1SC.

TUBE:

Black, oil resistant synthetic rubber.

REINFORCEMENT:

One braid of high tensile steel wire.

COVER:

Black, oil resistant synthetic rubber. No skiving required with T2000 Series Crimp Couplings.

TEMPERATURE RANGE:

From -40°C to +100°C (-40°F to +212°F).

WORKING PRESSURE:

Maximum working pressures are based on 4:1 safety factor (maximum working pressure to minimum burst pressure).

COUPLINGS:

NON-SKIVE ONE-PIECE CRIMP

T2000 Series (sizes -04 to -16).
Assembly Instructions pages 146.

EC1 - ENERGY COMPACT															
PART NO	HOSE SIZE	NOMINAL HOSE ID		NOMINAL HOSE OD		MAXIMUM WORKING PRESSURE		MINIMUM BURST PRESSURE		MINIMUM BEND RADIUS		AVERAGE WEIGHT		COUPLING SERIES ONE PIECE	
Hose	DN	Dash	mm	inch	mm	inch	bar	psi	bar	psi	mm	inch	kg/m	lb/ft	NON-SKIVE
EC14	6	-04	6,6	1/4	12,2	0.48	225	3250	900	13000	50	2.0	0,20	0.13	T2000
EC15	8	-05	8,2	5/16	13,9	0.55	215	3100	860	12400	55	2.2	0,22	0.15	T2000
EC16	10	-06	9,8	3/8	15,6	0.61	180	2600	720	10400	65	2.6	0,26	0.17	T2000
EC18	12	-08	13,0	1/2	19,0	0.75	160	2300	640	9200	85	3.3	0,33	0.22	T2000
EC110	16	-10	16,2	5/8	22,2	0.80	130	1900	520	7600	100	3.9	0,44	0.30	T2000
EC112	19	-12	19,1	3/4	25,6	1.01	105	1500	420	6000	115	4.5	0,50	0.34	T2000
EC116	25	-16	25,4	1	33,6	1.32	90	1280	360	5120	150	5.9	0,75	0.50	T2000

Refer to the latest Ryco Digital Crimp Tools for crimping parameters.



EC2
ENERGY COMPACT
TWO WIRE BRAID HOSE

RECOMMENDED FOR:

High pressure hydraulic oil lines. Ideal for high pressure use that requires a compact outside diameter and smaller bend radius than some other two wire braid hoses.

PERFORMANCE:

Meets or Exceeds the Performance Requirements of: EN 857 Type 2SC, ISO 11237 Type 2SC, SAE 100R16.

TUBE:

Black, oil resistant synthetic rubber.

REINFORCEMENT:

Two braids of high tensile steel wire.

COVER:

Black, oil resistant synthetic rubber. No skiving required with T2000 Series Crimp Couplings.

TEMPERATURE RANGE:

From -40°C to +100°C (-40°F to +212°F).

WORKING PRESSURE:

Maximum working pressures are based on 4:1 safety factor (maximum working pressure to minimum burst pressure).

COUPLINGS:

NON-SKIVE ONE-PIECE CRIMP

T2000 Series (sizes -04 to -16).
Assembly Instructions pages 146.

EC2 - ENERGY COMPACT															
PART NO	HOSE SIZE	NOMINAL HOSE ID		NOMINAL HOSE OD		MAXIMUM WORKING PRESSURE		MINIMUM BURST PRESSURE		MINIMUM BEND RADIUS		AVERAGE WEIGHT		COUPLING SERIES ONE PIECE	
Hose	DN	Dash	mm	inch	mm	inch	bar	psi	bar	psi	mm	inch	kg/m	lb/ft	NON-SKIVE
EC24	6	-04	6,6	1/4	13,4	0.53	400	5800	1600	23200	50	2.0	0,28	0.19	T2000
EC25	8	-05	8,2	5/16	14,9	0.59	350	5100	1400	20400	55	2.2	0,41	0.27	T2000
EC26	10	-06	9,8	3/8	17,3	0.68	330	4800	1320	19200	65	2.5	0,43	0.29	T2000
EC28	12	-08	13,0	1/2	20,3	0.80	275	4000	1100	16000	90	3.5	0,51	0.34	T2000
EC210	16	-10	16,2	5/8	23,6	0.93	250	3625	1000	14500	100	4.0	0,63	0.42	T2000
EC212	19	-12	19,1	3/4	27,6	1.09	215	3100	860	12400	120	4.7	0,81	0.55	T2000
EC216	25	-16	25,4	1	35,8	1.40	165	2400	660	9700	150	5.9	1,10	0.74	T2000

Refer to the latest Ryco Digital Crimp Tools for crimping parameters.

HOSES

BRAID

ECP1 PILOT

PILOT
COMPACT ONE WIRE BRAID HOSE



RECOMMENDED FOR:

High pressure hydraulic oil pilot lines. Compact dimensions and very small bend radius are advantages in installations where space is limited.

CONSTRUCTION:

Ryco Proprietary ECP1 Design.

TUBE:

Black, oil resistant synthetic rubber.

REINFORCEMENT:

One braid of high tensile steel wire.

COVER:

Black, oil resistant synthetic rubber. No skiving required with T2000 Series Crimp Couplings.

FEATURES:

Light and extremely flexible, with compact dimensions and a very small bend radius that are advantages in installations where space is limited. Low volumetric expansion ensures maximum responsiveness of hydraulic controls.

TEMPERATURE RANGE:

From -40°C to +100°C (-40°F to +212°F), with intermittent operation up to +121°C (+250°F).

WORKING PRESSURE:

Maximum working pressures are based on 4:1 safety factor (maximum working pressure to minimum burst pressure).

COUPLINGS:

NON-SKIVE ONE-PIECE CRIMP

T2000 Series (sizes -03 to -08).

Assembly Instructions pages 146.

ECP1 - PILOT COMPACT															
PART NO	HOSE SIZE	NOMINAL HOSE ID		NOMINAL HOSE OD		MAXIMUM WORKING PRESSURE		MINIMUM BURST PRESSURE		MINIMUM BEND RADIUS		AVERAGE WEIGHT		COUPLING SERIES ONE PIECE	
Hose	DN	Dash	mm	inch	mm	inch	bar	psi	bar	psi	mm	inch	kg/m	lb/ft	NON-SKIVE
ECP13	5	-03	5,0	3/16	10,3	0.41	125	1800	500	7200	25	1.0	0.11	0.05	T2000
ECP14	6	-04	6,7	1/4	11,8	0.46	125	1800	500	7200	30	1.2	0.14	0.06	T2000
ECP15	8	-05	8,3	5/16	13,3	0.52	125	1800	500	7200	40	1.6	0.16	0.07	T2000
ECP16	10	-06	9,9	3/8	14,9	0.59	125	1800	500	7200	50	2.0	0.19	0.09	T2000
ECP18	12	-08	13,0	1/2	18,3	0.72	125	1800	500	7200	60	2.4	0.28	0.13	T2000

Refer to the latest Ryco Digital Crimp Tools for crimping parameters.

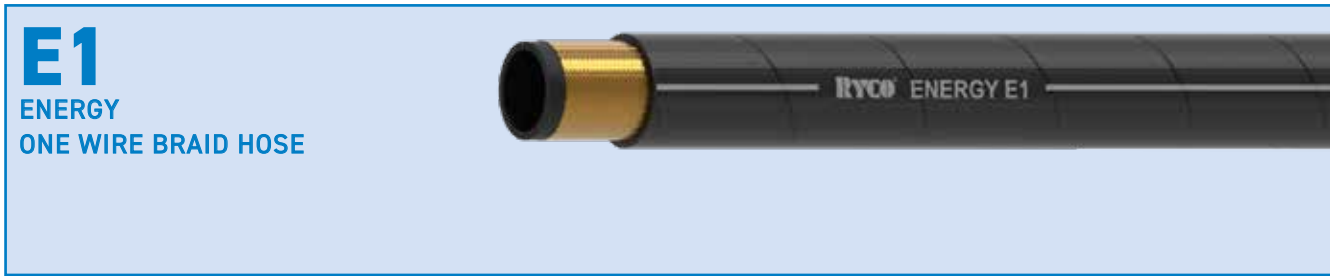

E1
ENERGY
ONE WIRE BRAID HOSE

RECOMMENDED FOR:

High pressure hydraulic oil lines.

PERFORMANCE:

Meets or Exceeds the Performance Requirements of: AS 3791 100R1AT, DIN 20022-1SN, EN 853 Type 1SN, ISO 1436 Types R1AT & 1SN, SAE 100R1AT.

TUBE:

Black, oil resistant synthetic rubber.

REINFORCEMENT:

One braid of high tensile steel wire.

COVER:

Black, oil resistant synthetic rubber. No skiving required with T2000 Series Crimp Couplings and K000 Series Field Attachable Couplings.

TEMPERATURE RANGE:

From -40°C to +100°C (-40°F to +212°F).

WORKING PRESSURE:

Maximum working pressures are based on 4:1 safety factor (maximum working pressure to minimum burst pressure).

COUPLINGS:

NON-SKIVE ONE-PIECE CRIMP

T2000 Series (sizes -04 to -16).
Assembly Instructions pages 146.

FIELD ATTACHABLE NON-SKIVE

6000 SERIES insert (sizes -04 to -16).
K000 Series ferrule (sizes -04 to -16).
Assembly Instructions page 142.

E1 - ENERGY																
PART NO	HOSE SIZE	NOMINAL HOSE ID		NOMINAL HOSE OD		MAXIMUM WORKING PRESSURE		MINIMUM BURST PRESSURE		MINIMUM BEND RADIUS		AVERAGE WEIGHT		ONE PIECE	FIELD ATT	
Hose	DN	Dash	mm	inch	mm	inch	bar	psi	bar	psi	mm	inch	kg/m	lb/ft	NON-SKIVE	
E13	5	03	5,0	3/16	11,4	0.45	250	3,625	1000	14500	90	3.5	0,18	0.12	T2000	6000 (K000)
E14	6	-04	6,6	1/4	13,0	0.52	225	3250	900	13000	100	4.0	0,22	0.15	T2000	6000 (K000)
E15	8	-05	8,2	5/16	14,6	0.59	215	3100	860	12400	115	4.5	0,25	0.17	T2000	
E16	10	-06	9,8	3/8	16,7	0.68	180	2600	720	10400	125	5.0	0,31	0.21	T2000	6000 (K000)
E18	12	-08	13,0	1/2	20,0	0.80	160	2300	640	9200	180	7.0	0,39	0.26	T2000	6000 (K000)
E110	16	-10	16,2	5/8	23,4	0.93	130	1900	520	7600	200	7.9	0,49	0.33	T2000	6000 (K000)
E112	19	-12	19,1	3/4	27,4	1.09	105	1500	420	6000	240	9.5	0,62	0.42	T2000	6000 (K000)
E116	25	-16	25,4	1	35,8	1.40	90	1300	360	5120	300	11.8	0,90	0.60	T2000	6000 (K000)

Refer to the latest Ryco Digital Crimp Tools for crimping parameters.

HOSES

BRAID

E2

ENERGY

TWO WIRE BRAID HOSE



RECOMMENDED FOR:

High pressure hydraulic oil lines.

PERFORMANCE:

Meets or Exceeds the Performance Requirements of: AS 3791 100R2AT, DIN 20022 - 2SN, EN 853 Type 2SN, ISO 1436 Types R2AT & 2SN, SAE 100R2AT.

TUBE:

Black, oil resistant synthetic rubber.

REINFORCEMENT:

Two braids of high tensile steel wire.

COVER:

Black, oil resistant synthetic rubber. No skiving required with T2000 and T7000 Series Crimp Couplings and L000 Series Field Attachable Couplings.

TEMPERATURE RANGE:

From -40°C to +100°C (-40°F to +212°F).

WORKING PRESSURE:

Maximum working pressures are based on 4:1 safety factor (maximum working pressure to minimum burst pressure).

COUPLINGS:

NON-SKIVE ONE-PIECE CRIMP

T2000 Series (sizes -04 to -16).

T7000 Series (sizes -06 to -16) pages 274 to 304.

Assembly Instructions pages 146.

FIELD ATTACHABLE NON-SKIVE

6000 SERIES insert (sizes -04 to -16).

L000 Series ferrule (sizes -04 to -16).

Assembly Instructions page 142.

E2 - ENERGY																	
PART NO	HOSE SIZE	NOMINAL HOSE ID		NOMINAL HOSE OD		MAXIMUM WORKING PRESSURE		MINIMUM BURST PRESSURE		MINIMUM BEND RADIUS		AVERAGE WEIGHT		ONE PIECE	FIELD ATT		
Hose	DN	Dash	mm	inch	mm	inch	bar	psi	bar	psi	mm	inch	kg/m	lb/ft	NON-SKIVE		
E24	6	-04	6,6	1/4	14,6	0.59	400	5800	1600	23200	100	3.9	0,35	0.24	T2000		6000 (L000)
E25	8	-05	8,2	5/16	16,4	0.65	350	5100	1400	20400	115	4.5	0,42	0.28	T2000		
E26	10	-06	9,8	3/8	18,5	0.74	330	4800	1320	19200	125	5.0	0,51	0.34	T2000	T7000	6000 (L000)
E28	12	-08	13,0	1/2	21,7	0.86	275	4000	1100	16000	180	7.0	0,65	0.44	T2000	T7000	6000 (L000)
E210	16	-10	16,2	5/8	24,9	0.99	250	3625	1000	14500	200	7.9	0,75	0.50	T2000	T7000	6000 (L000)
E212	19	-12	19,1	3/4	28,9	1.15	215	3100	860	12400	240	9.5	0,93	0.62	T2000	T7000	6000 (L000)
E216	25	-16	25,4	1	37,3	1.48	165	2400	660	9600	300	11.8	1,30	0.87	T2000	T7000	6000 (L000)

Refer to the latest Ryco Digital Crimp Tools for crimping parameters.

T1D

EXTRA ABRASION RESISTANT FRAS ONE WIRE BRAID HOSE



RECOMMENDED FOR:

High pressure hydraulic oil lines in applications where the outside cover of the hose is subjected to abrasion that may cause premature failure of standard hoses.

PERFORMANCE:

Meets or Exceeds the Performance Requirements of: AS 3791 100R1AT, DIN 20022-1SN, EN 853 Type 1SN, ISO 1436 Types R1AT & 1SN, SAE 100R1AT.

TUBE:

Black, oil resistant synthetic rubber.

REINFORCEMENT:

One braid of high tensile steel wire.

COVER:

DIEHARD™ Black, oil and extra abrasion resistant synthetic rubber. Flame Resistant, Anti-Static (FRAS) & MSHA compliant. Highly visible layline branding for easy and permanent identification. No skiving required with T2000 Series Crimp Couplings and K000 Series Field Attachable Couplings.

FEATURES:

The very high abrasion resistant properties of the cover, combined with the high working pressures and excellent impulse life, when tested to EN 853 Type 1SN/SAE 100R1AT test conditions, result in increased service life and minimise equipment downtime.

FRAS - FLAME RESISTANCE AND ANTI-STATIC:

DIEHARD™ complies with Flame Resistant and Electrical Resistance (Anti-Static) requirements of Australian Standard AS 2660 and Methods of Test AS 1180.10B and 13A. Meets Flame Resistant Designation “U.S. MSHA” of the US Department of Labor, Mine Safety and Health Administration.

TEMPERATURE RANGE:

From -40°C to +100°C (-40°F to +212°F).
For water, emulsions etc. see page 58.

WORKING PRESSURE:

Maximum working pressures are based on 4:1 safety factor (maximum working pressure to minimum burst pressure).

THIRD PARTY APPROVALS:

ABS, DNV-GL, LR, MED, USCG, GOST-R, BV, RINA, KR & MA-KA.

COUPLINGS:

NON-SKIVE ONE-PIECE CRIMP

T2000 Series (sizes -03 to -32).
Assembly Instructions pages 146.

FIELD ATTACHABLE NON-SKIVE

6000 SERIES insert (sizes -03 to -16).
K000 Series ferrule (sizes -03 to -16).
Assembly Instructions page 142.

T1D - DIEHARD																COUPLING SERIES	
PART NO	HOSE SIZE	NOMINAL HOSE ID		NOMINAL HOSE OD		MAXIMUM WORKING PRESSURE		MINIMUM BURST PRESSURE		MINIMUM BEND RADIUS		AVERAGE WEIGHT		ONE PIECE	FIELD ATT		
Hose	DN	Dash	mm	inch	mm	inch	bar	psi	bar	psi	mm	inch	kg/m	lb/ft	NON-SKIVE		
T13D	5	-03	4,8	3/16	11,7	0.46	250	3600	1000	14500	35	1.4	0,19	0.13	T2000	6000 (K000)	
T14D	6	-04	6,6	1/4	13,3	0.52	225	3250	900	13000	40	1.5	0,22	0.15	T2000	6000 (K000)	
T15D	8	-05	8,2	5/16	14,9	0.59	215	3100	860	12400	50	2.0	0,25	0.17	T2000		
T16D	10	-06	9,8	3/8	17,3	0.68	180	2600	720	10400	50	2.0	0,31	0.21	T2000	6000 (K000)	
T18D	12	-08	13,0	1/2	20,3	0.80	160	2300	640	9200	75	3.0	0,39	0.26	T2000	6000 (K000)	
T110D	16	-10	16,2	5/8	23,6	0.93	130	1900	520	7600	90	3.5	0,49	0.33	T2000	6000 (K000)	
T112D	19	-12	19,1	3/4	27,6	1.09	105	1500	420	6000	110	4.3	0,62	0.42	T2000	6000 (K000)	
T116D	25	-16	25,4	1	35,5	1.40	90	1300	360	5200	140	5.5	0,90	0.60	T2000	6000 (K000)	
T120D	31	-20	31,8	1.1/4	43,2	1.70	65	945	260	3780	210	8.3	1,21	0.81	T2000		
T124D	38	-24	38,1	1.1/2	50,2	1.98	50	725	200	2900	250	9.8	1,45	0.97	T2000		
T132D	51	-32	50,8	2	63,6	2.50	40	580	160	2320	315	12.4	2,09	1.40	T2000		

Refer to the latest Ryco Digital Crimp Tools for crimping parameters.

HOSES

BRAID

T1S

**EXTREMELY ABRASION RESISTANT
ONE WIRE BRAID HOSE**



RECOMMENDED FOR:

High pressure hydraulic oil lines.

PERFORMANCE:

Meets or Exceeds the Performance Requirements of: AS 3791 100R1AT, DIN 20022-1SN, EN 853 Type 1SN, ISO 1436 Types R1AT & 1SN, SAE 100R1AT.

TUBE:

Black, oil resistant synthetic rubber.

REINFORCEMENT:

One braid of high tensile steel wire.

COVER:

SLIDER Black, oil and extremely abrasion resistant synthetic rubber sheathed with a layer of extremely abrasion resistant polyethylene. Flame Resistant, MSHA compliant. Highly visible layline branding for easy and permanent identification. No skiving required with T2000 Series Crimp Couplings.

MSHA - FLAME RESISTANCE:

SLIDER complies with Flame Resistant requirements of Australian Standard AS 2660 and Methods of Test AS 1180.10B. Meets Flame Resistant Designation "U.S. MSHA" of the US Department of Labor, Mine Safety and Health Administration.

TEMPERATURE RANGE:

From -40°C to +100°C (-40°F to +212°F).
For water, emulsions etc. see page 58..

WORKING PRESSURE:

Maximum working pressures are based on 4:1 safety factor (maximum working pressure to minimum burst pressure).

THIRD PARTY APPROVALS:

ABS, DNV-GL, LR, MED, USCG, GOST-R, BV, RINA, KR & MA-KA.

COUPLINGS:

NON-SKIVE ONE-PIECE CRIMP

T2000 Series (sizes -03 to -32).

Assembly Instructions pages 146.

T1S - SLIDER															
PART NO	HOSE SIZE	NOMINAL HOSE ID		NOMINAL HOSE OD		MAXIMUM WORKING PRESSURE		MINIMUM BURST PRESSURE		MINIMUM BEND RADIUS		AVERAGE WEIGHT		COUPLING SERIES ONE PIECE	
Hose	DN	Dash	mm	inch	mm	inch	bar	psi	bar	psi	mm	inch	kg/m	lb/ft	NON-SKIVE
T13S	5	-03	4,8	3/16	11,7	0.46	250	3600	1000	14500	35	1.4	0,19	0.13	T2000
T14S	6	-04	6,6	1/4	13,3	0.52	225	3250	900	13000	40	1.5	0,22	0.15	T2000
T15S	8	-05	8,2	5/16	14,9	0.59	215	3100	860	12400	50	2.0	0,25	0.17	T2000
T16S	10	-06	9,8	3/8	17,3	0.68	180	2600	720	10400	50	2.0	0,31	0.21	T2000
T18S	12	-08	13,0	1/2	20,3	0.80	160	2300	640	9200	75	3.0	0,39	0.26	T2000
T110S	16	-10	16,2	5/8	23,6	0.93	130	1900	520	7600	90	3.5	0,49	0.33	T2000
T112S	19	-12	19,1	3/4	27,6	1.09	105	1500	420	6000	110	4.3	0,62	0.42	T2000
T116S	25	-16	25,4	1	35,5	1.40	90	1300	360	5200	140	5.5	0,90	0.60	T2000
T120S	31	-20	31,8	1.1/4	43,2	1.70	65	945	260	3780	210	8.3	1,21	0.81	T2000
T124S	38	-24	38,1	1.1/2	50,2	1.98	50	725	200	2900	250	9.8	1,45	0.97	T2000
T132S	51	-32	50,8	2	63,6	2.50	40	580	160	2320	315	12.4	2,09	1.40	T2000

Refer to the latest Ryco Digital Crimp Tools for crimping parameters.

T1F

FIRE SUPPRESSION ONE WIRE BRAID HOSE



RECOMMENDED FOR

Use in Fire Suppression Systems of off-road vehicles, mining equipment, stationary engines, etc. The hose is coloured red, for easy identification as part of the Fire Suppression System.

PERFORMANCE:

Meets or Exceeds the Performance Requirements of: AS 3791 100R1AT, DIN 20022-1SN, EN 853 Type 1SN, ISO 1436 Types R1AT & 1SN, SAE 100R1AT.

TUBE:

Black, oil resistant synthetic rubber. Resistant to aqueous film forming foam, dry chemical powder, carbon dioxide, and water based fire extinguishing agents.

REINFORCEMENT:

One braid of high tensile steel wire.

COVER:

Red, heat resistant, abrasion resistant and oil resistant rubber. Flame Resistant to Australian Standard AS 2660 and U.S. MSHA requirements. Highly visible layline branding for easy and permanent identification. No skiving required with T2000 Series Crimp Couplings and K000 Series Field Attachable Couplings.

FRAS - FLAME RESISTANCE AND ANTI-STATIC:

Complies with Flame Resistant requirements of Australian Standard AS 2660 and Method of Test AS 1180.10B Meets Flame Resistant Designation "U.S. MSHA" of the US Department of Labor, Mine Safety and Health Administration.

TEMPERATURE RANGE:

From -40°C to +100°C (-40°F to +212°F).
For water, emulsions etc. see page 58..

WORKING PRESSURE:

Maximum working pressures are based on 4:1 safety factor (maximum working pressure to minimum burst pressure).

THIRD PARTY APPROVALS:

ABS, DNV-GL, LR, MED, USCG, GOST-R, BV, RINA and KR.

COUPLINGS:

NON-SKIVE ONE-PIECE CRIMP

T2000 Series (sizes -03 to -16).
Assembly Instructions pages 146.

FIELD ATTACHABLE NON-SKIVE

6000 SERIES insert (sizes -03 to -16).
K000 Series ferrule (sizes -03 to -16).
Assembly Instructions page 142.

T1F - FIRE SUPPRESSION																
PART NO	HOSE SIZE	NOMINAL HOSE ID		NOMINAL HOSE OD		MAXIMUM WORKING PRESSURE		MINIMUM BURST PRESSURE		MINIMUM BEND RADIUS		AVERAGE WEIGHT		COUPLING SERIES		
		mm	inch	mm	inch	bar	psi	bar	psi	mm	inch	kg/m	lb/ft	ONE PIECE	FIELD ATT	
Hose	DN	Dash	mm	inch	mm	inch	bar	psi	bar	psi	mm	inch	kg/m	lb/ft	NON-SKIVE	
T13F	5	-03	4,8	3/16	11,7	0.46	250	3600	1000	14500	90	3.5	0,19	0.13	T2000	6000 (K000)
T14F	6	-04	6,6	1/4	13,3	0.52	225	3250	900	13000	100	3.9	0,22	0.15	T2000	6000 (K000)
T15F	8	-05	8,2	5/16	14,9	0.59	215	3100	860	12400	115	4.5	0,25	0.17	T2000	
T16F	10	-06	9,8	3/8	17,3	0.68	180	2600	720	10400	125	5.0	0,31	0.21	T2000	6000 (K000)
T18F	12	-08	13,0	1/2	20,3	0.80	160	2300	640	9200	180	7.0	0,39	0.26	T2000	6000 (K000)
T110F	16	-10	16,2	5/8	23,6	0.93	130	1900	520	7600	200	7.9	0,49	0.33	T2000	6000 (K000)
T112F	19	-12	19,1	3/4	27,6	1.09	105	1500	420	6000	240	9.5	0,62	0.41	T2000	6000 (K000)
T116F	25	-16	25,4	1	35,5	1.40	90	1300	360	5200	300	11.8	0,90	0.60	T2000	6000 (K000)

Refer to the latest Ryco Digital Crimp Tools for crimping parameters.

HOSES

BRAID

T2D

EXTRA ABRASION RESISTANT
FRAS
TWO WIRE BRAID HOSE



RECOMMENDED FOR:

High pressure hydraulic oil lines in applications where the outside cover of the hose is subjected to abrasion that may cause premature failure of standard hoses.

PERFORMANCE:

Meets or Exceeds the Performance Requirements of:
AS 3791 100R2AT, DIN 20022 - 2SN, EN 853 Type 2SN,
ISO 1436 Types R2AT & 2SN, SAE 100R2AT.

TUBE:

Black, oil resistant synthetic rubber.

REINFORCEMENT:

Two braids of high tensile steel wire.

COVER:

DIEHARD™ Black, oil and extra abrasion resistant synthetic rubber. Flame Resistant, Anti-Static (FRAS) & MSHA compliant. Highly visible layline branding for easy and permanent identification. No skiving required with T2000 and T7000 Series Crimp Couplings and L000 Series Field Attachable Couplings.

FEATURES:

The very high abrasion resistant properties of the cover, combined with the high working pressures and excellent impulse life when tested to EN 853 Type 2SN/SAE 100R2AT test conditions result in, increased service life and minimise equipment downtime.

FRAS - FLAME RESISTANCE AND ANTI-STATIC:

DIEHARD™ complies with Flame Resistant and Electrical Resistance (Anti-Static) requirements of Australian Standard AS 2660 and Methods of Test AS 1180.10B and 13A. Meets Flame Resistant Designation "U.S. MSHA" of the US Department of Labor, Mine Safety and Health Administration.

TEMPERATURE RANGE:

From -40°C to +100°C (-40°F to +212°F).
For water, emulsions etc. see page 58..

WORKING PRESSURE:

Maximum working pressures are based on 4:1 safety factor (maximum working pressure to minimum burst pressure).

THIRD PARTY APPROVALS:

ABS, DNV-GL, LR, MED, USCG, GOST-R, BV, RINA, KR & MA-KA.

COUPLINGS:

NON-SKIVE ONE-PIECE CRIMP

T2000 Series (sizes -04 to -48).

T7000 Series (sizes -06 to -32).

Assembly Instructions pages 146.

FIELD ATTACHABLE NON-SKIVE

6000 SERIES insert (sizes -04 to -20).

L000 Series ferrule (sizes -04 to -20).

Assembly Instructions page 142.

T2D - DIEHARD																
PART NO	HOSE SIZE	NOMINAL HOSE ID		NOMINAL HOSE OD		MAXIMUM WORKING PRESSURE		MINIMUM BURST PRESSURE		MINIMUM BEND RADIUS		AVERAGE WEIGHT		ONE PIECE	FIELD ATT	
Hose	DN	Dash	mm	inch	mm	inch	bar	psi	bar	psi	mm	inch	kg/m	lb/ft	NON-SKIVE	
T24D	6	-04	6,6	1/4	14,6	0.59	420	6100	1680	24400	100	3.9	0,35	0.24	T2000	6000 (L000)
T25D	8	-05	8,2	5/16	16,4	0.65	350	5100	1400	20400	114	4.5	0,42	0.28	T2000	
T26D	10	-06	9,8	3/8	18,5	0.74	350	5100	1400	20400	125	5.0	0,51	0.34	T2000	T7000 6000 (L000)
T28D	12	-08	13,0	1/2	21,7	0.86	350	5100	1400	20400	178	7.0	0,65	0.44	T2000	T7000 6000 (L000)
T210D	16	-10	16,2	5/8	24,9	0.99	250	3600	1000	14400	200	7.9	0,75	0.50	T2000	T7000 6000 (L000)
T212D	19	-12	19,1	3/4	28,9	1.15	215	3100	860	12400	240	9.5	0,93	0.62	T2000	T7000 6000 (L000)
T216D	25	-16	25,4	1	37,3	1.48	175	2500	700	10000	300	11.8	1,30	0.87	T2000	T7000 6000 (L000)
T220D	31	-20	31,8	1.1/4	47,2	1.87	140	2000	560	8000	420	16.5	1,97	1.33	T2000	T7000 6000 (L000)
T224D	38	-24	38,1	1.1/2	54,2	2.13	100	1450	400	5800	500	19.7	2,48	1.67	T2000	T7000
T232D	51	-32	50,8	2	66,8	2.63	90	1300	360	5200	600	23.6	3,02	2.03	T2000	T7000
T240D	63	-40	63,5	2.1/2	78.5	3.09	105	1520	420	6091	760	29.9	3,70	2.49	T2000	
T248D	76	-48	76,2	3	93.6	3.68	80	1160	320	4641	900	35.4	3,99	2.68	T2000	

When using B000 Series Field Attachable Couplings on T2D Series Hose, cover of hose must be skived at ends.
Refer to the latest Ryco Digital Crimp Tools for crimping parameters.



T2S
EXTREMELY ABRASION RESISTANT
TWO WIRE BRAID HOSE

RECOMMENDED FOR:

High pressure hydraulic oil lines in applications where the outside cover of the hose is subjected to sliding abrasion that may cause premature failure of standard hoses.

PERFORMANCE:

Meets or Exceeds the Performance Requirements of: AS 3791 100R2AT, DIN 20022-2SN, EN 853 Type 2SN, ISO 1436 Type 2AT, SAE 100R2AT.

TUBE:

Black, oil resistant synthetic rubber.

REINFORCEMENT:

Two braids of high tensile steel wire.

COVER:

SLIDER Black, oil and extremely abrasion resistant synthetic rubber sheathed with a layer of extremely abrasion resistant polyethylene. Flame Resistant, MSHA compliant. Highly visible layline branding for easy and permanent identification. No skiving required with T2000 & T7000 Series Crimp Couplings.

MSHA - FLAME RESISTANCE:

SLIDER complies with Flame Resistant requirements of Australian Standard AS 2660 and Methods of Test AS 1180.10B. Meets Flame Resistant Designation "U.S. MSHA" of the US Department of Labor, Mine Safety and Health Administration.

TEMPERATURE RANGE:

From -40°C to +100°C (-40°F to +212°F).
For water, emulsions etc. see page 58.

WORKING PRESSURE:

Maximum working pressures are based on 4:1 safety factor (maximum working pressure to minimum burst pressure).

THIRD PARTY APPROVALS:

ABS, DNV-GL, LR, MED, USCG, GOST-R, BV, RINA, KR & MA-KA.

COUPLINGS:

NON-SKIVE ONE-PIECE CRIMP

T2000 Series (sizes -04 to -32).

T7000 Series (sizes -05 to -32).

Assembly Instructions pages 146.

T2S - SLIDER																
PART NO	HOSE SIZE	NOMINAL HOSE ID		NOMINAL HOSE OD		MAXIMUM WORKING PRESSURE		MINIMUM BURST PRESSURE		MINIMUM BEND RADIUS		AVERAGE WEIGHT		COUPLING SERIES ONE PIECE		
Hose	DN	Dash	mm	inch	mm	inch	bar	psi	bar	psi	mm	inch	kg/m	lb/ft	NON-SKIVE	
T24S	6	-04	6,6	1/4	14,9	0.59	420	6100	1680	24400	100	3.9	0,35	0.24	T2000	
T25S	8	-05	8,2	5/16	16,5	0.65	350	5100	1400	20400	114	4.5	0,42	0.28	T2000	
T26S	10	-06	9,8	3/8	18,9	0.74	350	5100	1400	20400	125	5.0	0,51	0.34	T2000	T7000
T28S	12	-08	13,0	1/2	21,9	0.86	350	5100	1400	20400	178	7.0	0,65	0.44	T2000	T7000
T210S	16	-10	16,2	5/8	25,1	0.99	250	3600	1000	14400	200	7.9	0,75	0.50	T2000	T7000
T212S	19	-12	19,1	3/4	29,1	1.15	215	3100	860	12400	240	9.5	0,93	0.62	T2000	T7000
T216S	25	-16	25,4	1	37,5	1.48	175	2500	700	10000	300	11.8	1,30	0.87	T2000	T7000
T220S	31	-20	31,8	1.1/4	47,6	1.87	140	2000	560	8000	420	16.5	1,97	1.33	T2000	T7000
T224S	38	-24	38,1	1.1/2	54,1	2.13	100	1450	400	5800	500	19.7	2,48	1.67	T2000	T7000
T232S	51	-32	50,8	2	66,8	2.63	90	1300	360	5200	600	23.6	3,02	2.03	T2000	T7000

Refer to the latest Ryco Digital Crimp Tools for crimping parameters.

HOSES

BRAID

T2C LOW TEMPERATURE HOSE



RECOMMENDED FOR:

High pressure hydraulic oil lines in applications where low temperature environmental conditions exist.

PERFORMANCE:

Meets or Exceeds the Performance Requirements of: AS 3791 100R2AT, DIN 20022-2SN, EN 853 Type 2SN, ISO 1436 Types R2AT & 2SN, SAE 100R2AT.

TUBE:

Black, specially formulated oil resistant synthetic rubber.

REINFORCEMENT:

Two braids of high tensile steel wire.

COVER:

Black, oil resistant and abrasion resistant synthetic rubber. No skiving required with T2000 Series Crimp Couplings.

FEATURES:

Low Temperature hose (-60°C/-76°F).

TEMPERATURE RANGE:

From -60°C to +100°C (-76°F to +212°F).

For water, emulsions etc. see page 58.

WORKING PRESSURE:

Maximum working pressures are based on 4:1 safety factor (maximum working pressure to minimum burst pressure).

THIRD PARTY APPROVALS:

ABS, DNV-GL, LR, MED, USCG, GOST-R, BV, RINA and KR.

COUPLINGS:

NON-SKIVE ONE-PIECE CRIMP

T2000 Series (sizes -04 to -32).

Assembly Instructions pages 146.

T2C - ICEBREAKER															
PART NO	HOSE SIZE	NOMINAL HOSE ID		NOMINAL HOSE OD		MAXIMUM WORKING PRESSURE		MINIMUM BURST PRESSURE		MINIMUM BEND RADIUS		AVERAGE WEIGHT		COUPLING SERIES ONE PIECE	
Hose	DN	Dash	mm	inch	mm	inch	bar	psi	bar	psi	mm	inch	kg/m	lb/ft	NON-SKIVE
T24C	6	-04	6,6	1/4	15,0	0.59	420	6100	1680	24400	100	3.9	0,38	0.26	T2000
T25C	8	-05	8,2	5/16	16,6	0.65	350	5100	1400	20400	114	4.5	0,46	0.31	T2000
T26C	10	-06	9,8	3/8	19,0	0.75	350	5100	1400	20400	125	5.0	0,56	0.38	T2000
T28C	12	-08	13,0	1/2	22,2	0.87	350	5100	1400	20400	178	7.0	0,65	0.44	T2000
T210C	16	-10	16,2	5/8	25,2	0.99	250	3600	1000	14400	200	7.9	0,80	0.54	T2000
T212C	19	-12	19,1	3/4	29,1	1.15	215	3100	860	12400	240	9.5	0,94	0.63	T2000
T216C	25	-16	25,4	1	37,2	1.46	175	2500	700	10000	300	11.8	1,31	0.88	T2000
T220C	31	-20	31,8	1.1/4	47,4	1.87	140	2000	560	8000	420	16.5	1,91	1.28	T2000
T224C	38	-24	38,1	1.1/2	53,8	2.12	100	1450	400	5800	500	19.7	2,14	1.44	T2000
T232C	51	-32	50,8	2	66,7	2.63	90	1300	360	5200	600	23.6	2,78	1.87	T2000

Refer to the latest Ryco Digital Crimp Tools for crimping parameters.

TXA2D

**EXTRA ABRASION RESISTANT
EXTRA HIGH PRESSURE
FRAS
TWO WIRE BRAID HOSE**



INTRODUCTION
HOSES
TECHNICAL

RECOMMENDED FOR:

High pressure hydraulic oil lines in applications where the outside cover of the hose is subjected to abrasion that may cause premature failure of standard hoses. Ideal for high pressure use that requires a smaller outside diameter (except -20 size), lighter weight, and more flexibility than spiral hose.

PERFORMANCE:

Meets or Exceeds the Performance Requirements of: AS 3791 100R2AT, BCS 174, DIN 20022-2SN, EN 853 Type 2SN, ISO 1436 Types R2AT & 2SN, SAE 100R2AT.

TUBE:

Black, oil resistant synthetic rubber.

REINFORCEMENT:

Two braids of high tensile steel wire.

COVER:

DIEHARD™ Black, oil and extra abrasion resistant synthetic rubber. Flame Resistant, Anti-Static (FRAS) & MSHA compliant. Highly visible layline branding for easy and permanent identification. No skiving required with T2000 & T7000 Series Crimp Couplings and L000 Series Field Attachable Couplings.

FEATURES:

The very high abrasion resistant properties of the cover, combined with the high working pressures and excellent impulse life, when tested to EN 853 Type 2SN/SAE 100R2AT test conditions, result in increased service life and minimise equipment downtime.

FLAME RESISTANCE:

Complies with Flame Resistant and Electrical Resistance (Anti-Static) requirements of Australian Standard AS 2660 and Methods of Test AS 1180.10B and 13A. Meets Flame Resistant Designation "U.S. MSHA" of the US Department of Labor, Mine Safety and Health Administration.

TEMPERATURE RANGE:

From -40°C to +100°C (-40°F to +212°F).
For water, emulsions etc. see page 58.

WORKING PRESSURE:

Maximum working pressures are based on 4:1 safety factor (maximum working pressure to minimum burst pressure).

THIRD PARTY APPROVALS:

ABS, DNV-GL, LR, MED, USCG, GOST-R, BV, RINA and KR.

COUPLINGS:

NON-SKIVE ONE-PIECE CRIMP

T2000 Series (sizes -08 to -16).
T7000 Series (sizes -08 to -16) pages 274 to 304.
Assembly Instructions pages 146.

FIELD ATTACHABLE NON-SKIVE

6000 SERIES insert (sizes -08 to -16).
L000 Series ferrule (sizes -08 to -16).
Assembly Instructions page 142.

TXA2D - DIEHARD		NOMINAL HOSE ID		NOMINAL HOSE OD		MAXIMUM WORKING PRESSURE		MINIMUM BURST PRESSURE		MINIMUM BEND RADIUS		AVERAGE WEIGHT		COUPLING SERIES		
PART NO	HOSE SIZE	mm	inch	mm	inch	bar	psi	bar	psi	mm	inch	kg/m	lb/ft	ONE PIECE	FIELD ATT	
TXA28D	12 -08	13,0	1/2	22,0	0.87	375	5440	1500	21760	178	7.0	0,72	0.48	T2000	T7000	6000 (L000)
TXA210D	16 -10	16,2	5/8	25,2	0.99	350	5100	1400	20400	200	8.0	0,87	0.58	T2000	T7000	6000 (L000)
TXA212D	19 -12	19,1	3/4	29,1	1.15	313	4530	1252	18120	240	9.5	1,11	0.75	T2000	T7000	6000 (L000)
TXA216D	25 -16	25,4	1	37,7	1.48	225	3250	900	13000	300	12.0	1,50	1.01	T2000	T7000	6000 (L000)
TXA220D	31 -20	44,0	1.73	47.6	1.87	175	2540	700	10152	419	16.49	2,04	1.38	T2000		6000 (L000)

Contact Ryco for Crimp Diameter and Mark Length for Couplings.

H12D

EXTRA ABRASION RESISTANT
VERY HIGH PRESSURE
FRAS
MULTI-SPIRAL HOSE



RECOMMENDED FOR:

Very high pressure hydraulic oil lines, in applications where the outside cover of the hose is subject to abrasion that may cause premature failure of standard hoses.

PERFORMANCE:

Meets or Exceeds the Performance Requirements of: AS 3791 100R12, EN 856 Type R12, EN 856 Type 4SP (-12 and above), ISO 3862 Type R12, SAE 100R12.

TUBE:

Black, oil resistant synthetic rubber.

REINFORCEMENT:

Four alternating layers of spiralled high tensile steel wire.

COVER:

DIEHARD™ Black, oil and extra abrasion resistant synthetic rubber. Flame Resistant, Anti-Static (FRAS) & MSHA compliant. Highly visible layline branding for easy and permanent identification. No skiving required with T7000 Series Crimp Couplings.

FEATURES:

The very high abrasion resistant properties of the cover, combined with the extra high working pressures and excellent impulse life, when tested to SAE 100R12 test conditions, result in increased service life and minimise equipment downtime.

FRAS - FLAME RESISTANCE AND ANTI-STATIC:

DIEHARD™ complies with Flame Resistant and Electrical Resistance (Anti-Static) requirements of Australian Standard AS 2660 and Methods of Test AS 1180.10B and 13A. Meets Flame Resistant Designation "U.S. MSHA" of the US Department of Labor, Mine Safety and Health Administration.

TEMPERATURE RANGE:

From -40°C to +121°C (-40°F to +250°F).
For water, emulsions etc. see page 58.

WORKING PRESSURE:

Maximum working pressures are based on 4:1 safety factor (maximum working pressure to minimum burst pressure).

THIRD PARTY APPROVALS:

ABS, DNV-GL, LR, MED, USCG, GOST-R, BV, RINA and KR.

COUPLINGS:

NON-SKIVE ONE-PIECE CRIMP

T7000 Series (sizes -06 to -40).
Assembly Instructions pages 146.

H12D - DIEHARD															
PART NO	HOSE SIZE	NOMINAL HOSE ID		NOMINAL HOSE OD		MAXIMUM WORKING PRESSURE		MINIMUM BURST PRESSURE		MINIMUM BEND RADIUS		AVERAGE WEIGHT		COUPLING SERIES ONE PIECE	
Hose	DN	Dash	mm	inch	mm	inch	bar	psi	bar	psi	mm	inch	kg/m	lb/ft	NON-SKIVE
H1206D	10	-06	9,5	3/8	19,3	0.76	350	5100	1400	20400	125	5.0	0,61	0.41	T7000
H1208D	12	-08	12,7	1/2	22,7	0.89	350	5100	1400	20400	178	7.0	0,78	0.52	T7000
H1210D	16	-10	15,9	5/8	26,2	1.03	350	5100	1400	20400	200	7.9	0,98	0.66	T7000
H1212D	19	-12	19,1	3/4	30,0	1.18	350	5100	1400	20400	240	9.5	1,21	0.81	T7000
H1216D	25	-16	25,4	1	37,4	1.47	350	5100	1400	20400	300	11.8	1,84	1.24	T7000
H1220D	31	-20	31,8	1.1/4	45,7	1.80	275	4000	1100	16000	400	15.8	2,34	1.57	T7000
H1224D	38	-24	38,1	1.1/2	53,0	2.09	255	3700	1020	14800	500	19.7	3,04	2.04	T7000
H1232D	51	-32	50,8	2	66,0	2.60	210	3050	840	12400	600	23.6	4,23	2.84	T7000
H1240D	63	-40	63,5	2.1/2	82,6	3.25	140	2000	560	8000	650	25.6	5,20	3.49	T7000

Refer to the latest Ryco Digital Crimp Tools for crimping parameters.

H12S

**EXTREMELY ABRASION RESISTANT
VERY HIGH PRESSURE
MULTI-SPIRAL HOSE**



RECOMMENDED FOR:

Very high pressure hydraulic oil lines, in applications where the outside cover of the hose is subject to sliding abrasion that may cause premature failure of standard hoses.

PERFORMANCE:

Meets or Exceeds the Performance Requirements of: AS 3791 100R12, EN 856 Type R12, EN 856 Type 4SP (-12 and above), ISO 3862 Type R12, SAE 100R12.

TUBE:

Black, oil resistant synthetic rubber.

REINFORCEMENT:

Four alternating layers of spiralled high tensile steel wire.

COVER:

SLIDER Black, oil and extremely abrasion resistant synthetic rubber sheathed with a layer of extremely abrasion resistant polyethylene. Flame Resistant, MSHA compliant. Highly visible layline branding for easy and permanent identification. No skiving required with T7000 Series Crimp Couplings.

FEATURES:

The extremely high abrasion resistant properties of the polyethylene sheathed cover, combined with the extra high working pressures and excellent impulse life, when tested to SAE 100R12 test conditions, result in increased service life and minimise equipment downtime.

MSHA - FLAME RESISTANCE:

SLIDER complies with Flame Resistant requirements of Australian Standard AS 2660 and Methods of Test AS 1180.10B. Meets Flame Resistant Designation "U.S. MSHA" of the US Department of Labor, Mine Safety and Health Administration.

TEMPERATURE RANGE:

From -40°C to +121°C (-40°F to +250°F).
For water, emulsions etc. see page 58.

WORKING PRESSURE:

Maximum working pressures are based on 4:1 safety factor (maximum working pressure to minimum burst pressure).







THIRD PARTY APPROVALS:

ABS, DNV-GL, LR, MED, USCG, GOST-R, BV, RINA and KR.

COUPLINGS:

NON-SKIVE ONE-PIECE CRIMP

T7000 Series (sizes -06 to -32).
Assembly Instructions pages 146.

H12S - SLIDER															
PART NO	HOSE SIZE	NOMINAL HOSE ID		NOMINAL HOSE OD		MAXIMUM WORKING PRESSURE		MINIMUM BURST PRESSURE		MINIMUM BEND RADIUS		AVERAGE WEIGHT		COUPLING SERIES ONE PIECE	
Hose	DN	Dash	mm	inch	mm	inch	bar	psi	bar	psi	mm	inch	kg/m	lb/ft	NON-SKIVE
H1206S	10	-06	9,5	3/8	19,3	0.76	350	5100	1400	20400	125	5.0	0,61	0.41	T7000
H1208S	12	-08	12,7	1/2	22,7	0.89	350	5100	1400	20400	178	7.0	0,78	0.52	T7000
H1210S	16	-10	15,9	5/8	26,2	1.03	350	5100	1400	20400	200	7.9	0,98	0.66	T7000
H1212S	19	-12	19,1	3/4	30,0	1.18	350	5100	1400	20400	240	9.5	1,21	0.81	T7000
H1216S	25	-16	25,4	1	37,4	1.47	350	5100	1400	20400	300	11.8	1,84	1.24	T7000
H1220S	31	-20	31,8	1.1/4	45,7	1.80	275	4000	1100	16000	400	15.8	2,34	1.57	T7000
H1224S	38	-24	38,1	1.1/2	53,0	2.09	255	3700	1020	14800	500	19.7	3,04	2.04	T7000
H1232S	51	-32	50,8	2	66,0	2.60	210	3050	840	12400	600	23.6	4,23	2.84	T7000

Refer to the latest Ryco Digital Crimp Tools for crimping parameters.

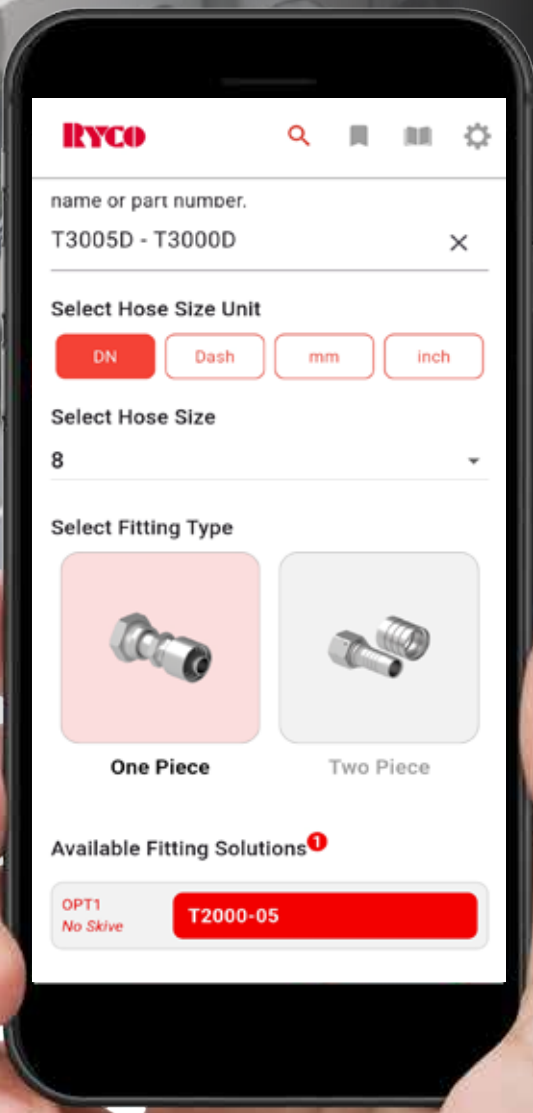

RYCO[®] CRIMP

YOUR SOURCE FOR THE MOST UP TO DATE CRIMP PARAMETERS

Stay up to date using Ryco's Digital Crimp Tools, available as an App and a Web version, our Crimp Tools are your go-to resource for accurate, efficient, and safe hydraulic hose crimping. Designed with professionals in mind, this innovative tool grants instant access to the latest crimp specifications, ensuring precision, and reliability in every assembly.

Whether in the workshop or on the go, Ryco Digital Crimp Tools provide real-time access to an extensive database of hose and fitting specifications, helping to reduce downtime and boost productivity.

Key Features of Ryco's Digital Crimp Tools:

Print Feature: This feature supports printing crimping parameters as reference charts for both single or multiple hose sizes within a selected hose family, supporting workshop and warehouse use.

Saved Items: Frequently used hose and fitting combinations can be saved within the app, allowing quick access to commonly used crimping parameters during routine hose assembly tasks.

Technical Centre: The Digital Crimp Tools are supported by a dedicated section on our website called the Technical Centre. This integrated resource provides expert insights, practical tips, and industry knowledge, with access to in depth guides and best practice information.

Current Crimping Parameters: To ensure accuracy on their crimping parameters, customers should regularly access the Ryco Digital Crimp Tools to check for updates. It is also recommended that printed charts should be reprinted regularly to ensure crimping information remains up to date.

Download the Manuli Crimp App Now



TJ2D

EXTRA ABRASION RESISTANT
FRAS
JACK HOSE
TWO WIRE BRAID



INTRODUCTION

HOSES

TECHNICAL

RECOMMENDED FOR:

Hydraulic Jack applications requiring a light weight, small outside diameter hose. The very high abrasion resistant properties of the DIEHARD cover extend the life of the hose when it is subjected to the abrasion that may cause the premature failure of standard hoses.

PERFORMANCE:

Meets or Exceeds the Performance Requirements of: Materials Handling Institute specification IJ 100 (July 1979) for hydraulic hose and assemblies used with jacking systems.

TUBE:

Black, oil resistant synthetic rubber.

REINFORCEMENT:

Two braids of high tensile steel wire.

COVER:

DIEHARD™ Black, oil and extra abrasion resistant synthetic rubber. Flame Resistant, Anti-Static (FRAS) & MSHA compliant. Highly visible layline branding for easy and permanent identification. No skiving required with T2000 Series Crimp Couplings.

FRAS - FLAME RESISTANCE AND ANTI-STATIC:

DIEHARD™ complies with Flame Resistant and Electrical Resistance (Anti-Static) requirements of Australian Standard AS 2660 and Methods of Test AS 1180.10B and 13A. Meets Flame Resistant Designation "U.S. MSHA" of the US Department of Labor, Mine Safety and Health Administration.

TEMPERATURE RANGE:

From -40°C to +49°C (-40°F to +120°F).
For water, emulsions etc. see page 58.

WORKING PRESSURE:

Specification IJ 100 (July 1979) is based on 2:1 minimum burst to maximum working pressure safety factor and is suitable for 700 bar/10,000 psi use in hydraulic jack applications ONLY.

COUPLINGS:

NON-SKIVE ONE-PIECE CRIMP

T2000 Series (sizes -04 to -06).
Assembly Instructions pages 146.

TJ2D - DIEHARD		NOMINAL HOSE ID		NOMINAL HOSE OD		MAXIMUM WORKING PRESSURE		MINIMUM BURST PRESSURE		MINIMUM BEND RADIUS		AVERAGE WEIGHT		COUPLING SERIES ONE PIECE	
PART NO	HOSE SIZE	mm	inch	mm	inch	bar	psi	bar	psi	mm	inch	kg/m	lb/ft	NON-SKIVE	
TJ24D	6	-04	6,6	1/4	14.9	0.59	700	10000	1400	20000	100	3.9	0.35	0.24	T2000
TJ26D	10	-06	9,8	3/8	18.9	0.74	700	10000	1400	20000	130	5.0	0.51	0.34	T2000

NOTE: Ensure rated Working Pressure of chosen End Style meets or exceeds the 700 bar/10,000 psi Maximum Working Pressure of TJ2D hose.

For hydraulic jack applications, Ryco recommends the use of 3/8" NPTF Male Extended Couplings.

TJ24D: Part No. T2091-0406 One-Piece Crimp. Use of Ryco 750 Spring Guards at each end of the hose assembly is also recommended.

TJ26D: Part No. T2091-0606 One-Piece Crimp. Use of a Bend Restrictor device at each end of the hose assembly is also recommended.

Refer to the latest Ryco Digital Crimp Tools for crimping parameters.

HOSES

SPECIALTY AND HIGH TEMPERATURE

JACK HOSE ASSEMBLIES

For ease of ordering, Hose Assemblies can be specified using TJ24 and TJ26 numbers below, followed by overall length in millimetres.

For example, to order a TJ24D Hose Assembly, 1800 mm overall length, with 3/8" NPTF male one end and male Screw-On coupling other end, with Spring Guards at each end; simply order TJ2402-1800.

Standard lengths are 1000 mm, 2000 mm and 3000 mm. Other lengths are available.

JACK HOSE ASSEMBLIES (HOSE ENDS INCLUDE RYCO 750 SPRING GUARD**)

HOSE ASSEMBLY No.	HOSE END 1	HOSE END 2
TJ2401-xxxx* TJ2601-xxxx*	3/8" NPTF Male	3/8" NPTF Male
TJ2402-xxxx* TJ2602-xxxx*	3/8" NPTF Male	R100-06M Male Tip
TJ2403-xxxx* TJ2603-xxxx*	3/8" NPTF Male	R100-06M Male Tip and R100-06DC Dust Cap
TJ2404-xxxx* TJ2604-xxxx*	3/8" NPTF Male	R100-06FM Male and Female Coupling
TJ2405-xxxx* TJ2605-xxxx*	3/8" NPTF Male	R100-06FMPC Male and Female Coupling with Dust Cap and Dust Plug

* Substitute xxxx for overall length (mm)

** Ryco 750 Spring Guard is only available to suit TJ24D hose assemblies.

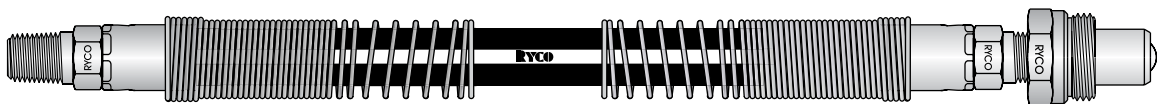

TJ2402 shown

R100 SERIES QUICK RELEASE COUPLINGS, 700 BAR/10,000 PSI, THREAD-TO-CONNECT.

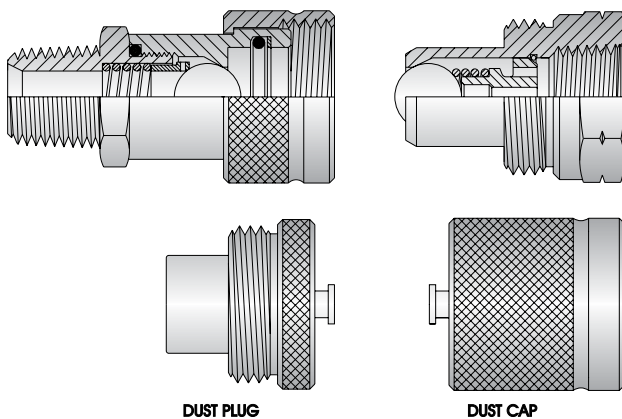

- Designed for use in heavy duty applications on portable cylinders, rams and pumps, where low flow rates and pressures up to 700 bar/10,000 psi are involved.
- Threaded sleeve on female body engages thread on male tip. When the sleeve is screwed completely up, the two coupling halves are secured together. Can connect and disconnect with pressure in line.
- Precision ball type check valves.
- Threaded dust caps and plugs complete with captive chain are available.
- Female body is NPTF male threaded to screw directly into the cylinder or ram.
- Male tip is NPTF female threaded to screw onto hose coupling.

NOMINAL SIZE	NPTF THREAD	MAXIMUM WORKING PRESSURE		FEMALE BODY	MALE TIP	COMPLETE COUPLING	DUST PLUG FOR MALE	DUST PLUG FOR FEMALE
		bar	psi					
1/4	1/4	700	10000	R100-04F	R100-04M	R100-04FM	R100-06DP	R100-06DC
3/8	3/8	700	10000	R100-06F	R100-06M	R100-06FM	R100-06DP	R100-06DC

For further information refer to Quick Release Couplings (QRC) Brochure on www.ryco-hydraulics.com.

D4000D

**EXTRA ABRASION RESISTANT
HIGH PRESSURE
FRAS
ULTRA FLEXIBLE MULTI-SPIRAL
HOSE FOR DRIFTER UNITS**



INTRODUCTION

HOSES

TECHNICAL

RECOMMENDED FOR:

High pressure hydraulic oil lines and Jumbo drill rig drifter (rock drill) units. The ultra flexible and tough construction improves service life in applications where the outside cover of the hose is subject to bending, abrasion and rockfall that may cause premature failure of standard hoses.

PERFORMANCE:

Meets or Exceeds the Performance Requirements of: ISO 18752-CC, AS 3791 100R12, EN 856 Type R12, ISO 3862 Type R12 & SAE 100R12.

Very small Minimum Bend Radius of up to 60% less than SAE 100R12.

TUBE:

Black, oil resistant synthetic rubber.

REINFORCEMENT:

Four alternating layers of spiralled high tensile steel wire.

COVER:

DIEHARD™ Black, oil and extra abrasion resistant synthetic rubber. Flame Resistant, Anti-Static (FRAS) & MSHA compliant. Embossed layline for positive, permanent identification. No skiving required with T7000 Series Crimp Couplings.

FEATURES:

The ultra flexibility combined with very high abrasion resistant properties of the hose cover provides the necessary attributes for drifter (rock drill) unit assemblies. Combined with the extra high working pressures and excellent impulse life, D4000D DRIFTER provides increased service life and minimises Jumbo equipment downtime.

FRAS - FLAME RESISTANCE AND ANTI-STATIC:

DIEHARD™ complies with Flame Resistant and Electrical Resistance (Anti-Static) requirements of Australian Standard AS 2660 and Methods of Test AS 1180.10B and 13A. Meets Flame Resistant Designation "U.S. MSHA" of the US Department of Labor, Mine Safety and Health Administration.

TEMPERATURE RANGE:

From -40°C to +121°C (-40°F to +250°F).

For water, emulsions etc. page 23.

COUPLINGS:

NON-SKIVE ONE-PIECE CRIMP

T7000 Series (sizes -08 to -16).

Assembly Instructions as per Ryco Product Technical Manual - Hydraulics pages 146.

D4000D - DRIFTER															
PART NO	HOSE SIZE	NOMINAL HOSE ID		NOMINAL HOSE OD		MAXIMUM WORKING PRESSURE		MINIMUM BURST PRESSURE		MINIMUM BEND RADIUS		AVERAGE WEIGHT		COUPLING SERIES ONE PIECE	
Hose	DN	Dash	mm	inch	mm	inch	bar	psi	bar	psi	mm	inch	kg/m	lb/ft	NON-SKIVE
D4008D	12	-08	13,0	1/2	21,9	0.86	280	4100	1120	16400	85	3.3	0,63	0.42	T7000
D4012D	19	-12	19,3	3/4	28,8	1.13	280	4100	1120	16400	85	3.3	0,98	0.66	T7000
D4016D	25	-16	25,8	1	35,6	1.40	280	4100	1120	16400	120	4.7	1,51	1.01	T7000

HOSES

SPECIALTY AND HIGH TEMPERATURE

SURVIVOR/1

HIGH TEMPERATURE
MULTI FLUID
ONE WIRE BRAID HOSE





RECOMMENDED FOR:

High pressure hydraulic oil applications where pressure or temperature requirements exceed the performance requirements of SAE 100R1AT and EN 853-1SN. May be used with compressed air if cover of hose is perforated (pinpricked) and additional Safety Devices are used. Refer to Fluid Compatibility Chart for applicable fluids for SURVIVOR range.

PERFORMANCE:

Meets or Exceeds the Performance Requirements of: EN 853-1SN, ISO 1436-R1AT & 1SN, SAE 100R1AT, AS 3791-100R1AT.

TUBE:

Black, synthetic rubber, specifically compounded for high temperature resistance.

REINFORCEMENT:

One braid of high tensile steel wire.

COVER:

SURVIVOR Blue, oil resistant and abrasion resistant synthetic rubber.

FEATURES:

High temperature and long lasting aging resistance. Outstanding ozone resistance. Superior weather and UV resistance. No-Skive couplings

FLAME RESISTANCE AND ANTI-STATIC:

Meets Flame Resistant Designation "U.S. MSHA" of the US Department of Labor, Mine Safety and Health Administration.

TEMPERATURE RANGE:

From -40°C to +135°C (-40°F to +275°F); Peaks of 150°C (300°F).

WORKING PRESSURE:

Maximum working pressures are based on 4:1 safety factor (maximum working pressure to minimum burst pressure).

THIRD PARTY APPROVALS:

MSHA

COUPLINGS:

NON-SKIVE ONE-PIECE CRIMP

T2000 Series

FIELD ATTACHABLE NON-SKIVE

6000 Series insert

K000 Series ferrule

SURVIVOR/1															
PART NO	HOSE SIZE		NOMINAL HOSE OD		MAXIMUM WORKING PRESSURE		MINIMUM BURST PRESSURE		MINIMUM BEND RADIUS		AVERAGE WEIGHT		COUPLING SERIES		
Hose	DN	Dash	inch	mm	inch	bar	psi	bar	psi	mm	inch	kg/m	lb/ft	NON-SKIVE	
SRV14*	6	-4	1/4"	13.4	0.52	225	3260	900	13053	100.0	3.93	0,24	0.16	T2000	6000 (K000)
SRV15*	8	-5	5/16"	15.0	0.59	215	3110	860	12473	114.0	4.48	0,28	0.19	T2000	
SRV16*	10	-6	3/8"	17.3	0.68	180	2610	720	10442	125.0	4.92	0,34	0.23	T2000	6000 (K000)
SRV18*	12	-8	1/2"	20.5	0.8	160	2320	640	9282	178.0	7.0	0,44	0.29	T2000	6000 (K000)
SRV110*	16	-10	5/8"	23.5	0.92	130	1880	520	7542	200.0	7.87	0,51	0.34	T2000	6000 (K000)
SRV112*	19	-12	3/4"	27.7	1.09	105	1520	420	6091	240.0	9.44	0,66	0.44	T2000	6000 (K000)
SRV116*	25	-16	1"	35.8	1.4	90	1300	360	5221	300.0	11.81	0,98	0.66	T2000	6000 (K000)
SRV120*	31	-20	1.1/4"	43.5	1.71	65	940	260	3771	420.0	16.53	0,13	0.89	T2000	
SRV124*	38	-24	1.1/2"	50.0	1.96	50	720	200	2900	500.0	19.68	0,15	1.05	T2000	
SRV132*	51	-32	2"	63.1	2.48	40	580	160	2320	630.0	24.8	0,21	1.44	T2000	
SRV140*	63	-40	2.1/2"	74.6	2.93	35	500	140	2030	760.0	29.92	0,24	1.61	T2000	
SRV148*	76	-48	3"	87.7	3.45	35	500	140	2030	900.0	35.43	0,26	1.75	T2000	

- SURVIVOR/1 may be used for compressed air applications but requires cover pin-pricking and additional safety devices.
- SURVIVOR/1 is not approved for "air brake" applications on railway and/or mobile equipment.
- SURVIVOR/1 is not suitable for high temperature water applications.
- Refer to the latest Ryco Digital Crimp Tools for crimping parameters.

SURVIVOR/2

HIGH TEMPERATURE
MULTI FLUID
TWO WIRE BRAID HOSE



RECOMMENDED FOR:

High pressure hydraulic oil applications where pressure or temperature requirements exceed the performance requirements of SAE 100R2AT and EN 853-2SN. May be used with compressed air if cover of hose is perforated (pinpricked) and additional Safety Devices are used. Refer to Fluid Compatibility Chart for applicable fluids for SURVIVOR range.

PERFORMANCE:

Meets or Exceeds the Performance Requirements of: SAE J517-100R2AT, EN 853-2SN, ISO 1436-R2AT & 2SN.

TUBE:

Black, synthetic rubber, specifically compounded for high temperature resistance.

REINFORCEMENT:

Two braids of high tensile steel wire.

COVER:

SURVIVOR Blue, oil resistant and abrasion resistant synthetic rubber.

FEATURES:

High temperature and long lasting aging resistance. Outstanding ozone resistance. Superior weather and UV resistance. No-Skive couplings.

MSHA - FLAME RESISTANCE:

Meets Flame Resistant Designation "U.S. MSHA" of the US Department of Labor, Mine Safety and Health Administration.

TEMPERATURE RANGE:

From -40°C to +135°C (-40°F to +275°F); Peaks of 150°C (300°F).

WORKING PRESSURE:

Maximum working pressures are based on 4:1 safety factor (maximum working pressure to minimum burst pressure).

THIRD PARTY APPROVALS:

MSHA.

COUPLINGS:

NON-SKIVE ONE-PIECE CRIMP

T2000 Series

T7000 Series

SURVIVOR/2															
PART NO	HOSE SIZE		NOMINAL HOSE OD		MAXIMUM WORKING PRESSURE		MINIMUM BURST PRESSURE		MINIMUM BEND RADIUS		AVERAGE WEIGHT		COUPLING SERIES		
Hose	DN	Dash	inch	mm	inch	bar	psi	bar	psi	mm	inch	kg/m	lb/ft	NON-SKIVE	
SRV24*	6	-4	1/4"	14.9	0.58	420	6090	1680	24366	100.0	3.93	0,38	0.26	T2000	
SRV25*	8	-5	5/16"	16.5	0.64	350	5070	1400	20305	114.0	4.48	0,43	0.29	T2000	
SRV26*	10	-6	3/8"	19.0	0.74	350	5070	1400	20305	125.0	4.92	0,52	0.35	T2000	T7000
SRV28*	12	-8	1/2"	22.0	0.86	300	4350	1200	17404	178.0	7.0	0,66	0.44	T2000	T7000
SRV210*	16	-10	5/8"	25.2	0.99	250	3625	1000	14504	200.0	7.87	0,77	0.52	T2000	T7000
SRV212*	19	-12	3/4"	29.0	1.14	215	3100	860	12473	240.0	9.44	0,95	0.64	T2000	T7000
SRV216*	25	-16	1"	37.0	1.45	175	2540	700	10152	300.0	11.81	0,13	0.89	T2000	T7000
SRV220*	31	-20	1.1/4"	47.0	1.85	150	2170	600	8702	420.0	16.53	0,21	1.41	T2000	T7000
SRV224*	38	-24	1.1/2"	53.4	2.1	100	1450	400	5801	500.0	19.68	0,27	1.53	T2000	T7000
SRV232*	51	-32	2"	66.2	2.6	90	1300	360	5221	630.0	24.8	0,31	2.1	T2000	T7000
SRV240*	63	-40	2.1/2"	76.0	2.99	70	1010	280	4061	760.0	29.92	0,29	1.95	T2000	
SRV248*	76	-48	3"	91.4	3.59	50	725	200	2900	900.0	35.43	0,31	2.1	T2000	

- SURVIVOR/2 may be used for compressed air applications but requires cover pin-pricking and additional safety devices.
- SURVIVOR/2 is not approved for "air brake" applications on railway and/or mobile equipment.
- SURVIVOR/2 is not suitable for high temperature water applications.
- Refer to the latest Ryco Digital Crimp Tools for crimping parameters.

HOSES

SPECIALTY AND HIGH TEMPERATURE

SURVIVOR/R5

HIGH TEMPERATURE
POLYESTER BRAID COVER
ONE WIRE BRAID HOSE



RECOMMENDED FOR:

Medium pressure hydraulic oil applications where pressure or temperature requirements exceed the performance requirements of SAE 100R5. May be used for compressed air applications with appropriate safety devices like whip-checks where required. Refer to Fluid Compatibility Chart for applicable fluids for SURVIVOR range.

PERFORMANCE:

Meets or Exceeds the Performance Requirements of: SAE J517-100R5, AS 3791 100R5, SAE J1402 Type All.

TUBE:

Black, synthetic rubber, specifically compounded for high temperature resistance.

REINFORCEMENT:

One braid of high tensile steel wire.

COVER:

Blue, polyester yarn braid.

FEATURES:

High temperature and long lasting aging resistance. Outstanding ozone resistance. Superior weather and UV resistance. No-Skive couplings.

TEMPERATURE RANGE:

From -40°C to +135°C (-40°F to +275°F); Peaks of 150°C (300°F).

WORKING PRESSURE:

Maximum working pressures are based on 4:1 safety factor (maximum working pressure to minimum burst pressure).

COUPLINGS:

NON-SKIVE ONE-PIECE CRIMP

T2000 Series

FIELD ATTACHABLE NON-SKIVE

V000 Series

PART NO	SURVIVOR/R5			NOMINAL HOSE OD		MAXIMUM WORKING PRESSURE		MINIMUM BURST PRESSURE		MINIMUM BEND R SAE100R5		AVERAGE WEIGHT		COUPLING SERIES	
	HOSE SIZE													ONE PC	FIELD
Hose	DN	Dash	inch	mm	inch	bar	psi	bar	psi	mm	inch	kg/m	lb/ft	NON-SKIVE	
SRVR55*	6	-5	1/4"	14,8	0.58	210	3050	840	2200	85,0	3.3	0,26	0.17	T2000	V000
SRVR56*	8	-6	5/16"	17,2	0.68	157	2270	628	9108	100,0	3.93	0,30	0.20	T2000	V000
SRVR58*	10	-8	13/32"	19,4	0.76	140	2030	560	8122	115,0	4.52	0,36	0.24	T2000	V000
SRVR510*	12	-10	1/2"	23,4	0.92	122	1760	488	7077	140,0	5.51	0,53	0.36	T2000	V000

- SURVIVOR/R5 may be used for compressed air applications but requires cover pin-pricking and additional safety devices.
- SURVIVOR/R5 is not approved for "air brake" applications on railway and/or mobile equipment.
- SURVIVOR/R5 is not suitable for high temperature water applications.
- Refer to the latest Ryco Digital Crimp Tools for crimping parameters.

D2B

DRILLER
HIGH TEMPERATURE
DRILL RIG HOSE



INTRODUCTION

HOSES

TECHNICAL

RECOMMENDED FOR:

Hydraulic oil or air lines. Drill rigs - high pressure, large bore air hose.

PERFORMANCE:
SAE 100R16 (SIZE -20).

TUBE:
Black, oil resistant synthetic rubber specifically compounded for temperature resistance.

REINFORCEMENT:
Two braids of high tensile steel wire.

COVER:
Perforated blue, oil and abrasion resistant synthetic rubber. No skiving required with T2000 & T7000 Series Crimp Couplings.

MSHA - FLAME RESISTANCE:

Complies with Flame Resistant requirements of Australian Standard AS 2660 and Method of Test AS 1180.10B. Meets Flame Resistant Designation "U.S. MSHA" of the US Department of Labor, Mine Safety and Health Administration.

TEMPERATURE RANGE:

Air: -40°C to +121°C (-40°F to +250°F)
Oil: -40°C to +135°C (-40°F to +275°F)

WORKING PRESSURE:

Maximum working pressures are based on 4:1 safety factor (maximum working pressure to minimum burst pressure).

THIRD PARTY APPROVALS:

ABS, DNV-GL, LR, MED, USCG, GOST-R, BV, RINA and KR.

COUPLINGS:

NON-SKIVE ONE-PIECE CRIMP

T2000 Series (sizes -20 to -32).

T7000 Series (sizes -24 to -32).

Assembly Instructions pages 146.

Not suitable for use with field attachable couplings.

D2B - DRILLER HOSE																
PART NO	HOSE SIZE	NOMINAL HOSE ID		NOMINAL HOSE OD		MAXIMUM WORKING PRESSURE		MINIMUM BURST PRESSURE		MINIMUM BEND RADIUS		AVERAGE WEIGHT		COUPLING SERIES ONE PIECE		
Hose	DN	Dash	mm	inch	mm	inch	bar	psi	bar	psi	mm	inch	kg/m	lb/ft	NON-SKIVE	
D220B	31	-20	31,8	1.1/4	40,4	1.59	140	2030	560	8120	200	7.9	1,22	0.82	T2000	
D224B	38	-24	38,1	1.1/2	48,0	1.89	100	1450	400	5800	250	9.8	1,49	1.00	T2000	T7000
D232B	51	-32	50,8	2	62,0	2.44	90	1300	360	5200	300	11.8	2,24	1.50	T2000	T7000

Refer to the latest Ryco Digital Crimp Tools for crimping parameters.

HOSES

SPECIALTY AND HIGH TEMPERATURE

T5

**POLYESTER BRAID COVER
ONE WIRE BRAID HOSE**

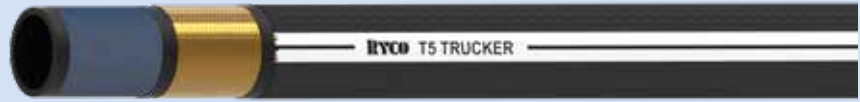

RECOMMENDED FOR:

Medium to high pressure hydraulic oil applications. The small bend radius, temperature resistance and light weight of Ryco T5 hose make it suitable for under the bonnet automotive/trucking applications including hydraulic oil, diesel fuel, lubrication oil and transmission oil coolers. Sizes T54 to T512 also comply with SAE J1402 Type All "Automotive Air Brake Hose" for use in truck "air brake systems including flexible connections from frame to axle, tractor to trailer, trailer to trailer, and other unshielded air lines that are exposed to potential pull or impact". T5 may be used with compressed air if maximum working pressure is reduced by 30%. T5 hose is normally used where there is minimal abrasion to the outside cover. If abrasion is likely, support the hose away from the source of abrasion using mounting clamps, or protect with RWA Wire Armour or RSG Spiral Guard. T5 is a reduced bore hose. It has a similar Inside Diameter to steel or copper tubing of the same nominal (outside diameter) size. See page 153 for more information.

PERFORMANCE:

Meets or Exceeds the Performance Requirements of: AS 3791 100R5, SAE 100R5, SAE J1402 Type All (up to -12 size).

TUBE:

Black, oil resistant synthetic rubber.

REINFORCEMENT:

Polyester inner braid covered with one braid of high tensile steel wire.

COVER:

Black polyester braid. Skiving of cover is not required.

MSHA - FLAME RESISTANCE:

Meets Flame Resistant Designation "U.S. MSHA" of the US Department of Labor, Mine Safety and Health Administration and Flame Resistant requirements of Australian Standard AS 2660 and Method of Test AS 1180.10B when used with FS1072 Fire Sleeve.

TEMPERATURE RANGE:

From -40°C to +100°C (-40°F to +212°F).
For water, emulsions etc. see page 58.

WORKING PRESSURE:

Maximum working pressures are based on 4:1 safety factor (maximum working pressure to minimum burst pressure).

THIRD PARTY APPROVALS:

ABS, DNV-GL, LR, MED, USCG, DOT, GOST-R, BV, RINA and KR.

COUPLINGS:

NON-SKIVE ONE-PIECE CRIMP

T4000 Series (Sizes -04 to -20).
Assembly Instructions pages 146.

FIELD ATTACHABLE NON-SKIVE

V000 Series (sizes -04 to -32).
Assembly Instructions page 142.

T5 - TRUCKER																				
PART NO	HOSE SIZE	NOMINAL HOSE ID		NOMINAL HOSE OD		MAXIMUM WORKING PRESSURE		MINIMUM BURST PRESSURE		MINIMUM BEND R SAE100R5		MINIMUM BEND R SAEJ1402		VACUUM RATING		AVERAGE WEIGHT		ONE PC	FIELD ATT	
Hose	DN	Dash	mm	inch	mm	inch	bar	psi	bar	psi	mm	inch	mm	inch	inHg	mmHg	kg/m	lb/ft	NON-SKIVE	
T54	5	-04	4,8	3/16	13,2	0.52	210	3050	840	12200	75	3.0	51	2.0	710	28	0,23	0.15	T4000	V000
T55	6	-05	6,4	1/4	14,8	0.58	210	3050	840	12200	85	3.3	64	2.5	710	28	0,26	0.17	T4000	V000
T56	8	-06	7,9	5/16	17,2	0.68	157	2250	628	9000	100	4.0	76	3.0	710	28	0,30	0.20	T4000	V000
T58	10	-08	10,3	13/32	19,4	0.76	140	2000	560	8000	115	4.6	89	3.5	710	28	0,36	0.24	T4000	V000
T510	12	-10	12,7	1/2	23,4	0.92	122	1750	488	7000	140	5.5	102	4.0	710	28	0,53	0.36	T4000	V000
T512	16	-12	15,9	5/8	27,4	1.08	105	1500	420	6000	165	6.5	114	4.5	710	28	0,65	0.44	T4000	V000
T516	22	-16	22,2	7/8	31,4	1.24	56	800	224	3200	187	7.4	N/A	N/A	510	20	0,63	0.42	T4000	V000
T520	28	-20	28,6	1.1/8	38,1	1.50	43	625	172	2500	229	9.0	N/A	N/A	510	20	0,90	0.60	T4000	V000
T524	35	-24	34,9	1.3/8	44,5	1.75	35	500	140	2000	267	10.5	N/A	N/A	380	15	1,00	0.67	T4000	V000
T532	46	-32	46,0	1.13/16	56,3	2.22	24	350	96	1400	337	13.3	N/A	N/A	280	11	1,48	0.99	T4000	V000

***IMPORTANT NOTE:** MAXIMUM WORKING PRESSURE and MINIMUM BURST PRESSURE shown above relate to SAE 100R5 specification and hose used in non Air Brake applications. For Air Brake applications, SAE J1402 Type All Air Brake Hose specification requires Minimum Burst Pressure 900 psi (62,1 bar) and Proof Pressure of 300 psi (20,7 bar) for all sizes, and reduced Minimum Bend Radii as shown below. T54 to T512 comply with SAE J1402 Minimum Bend Radius at SAE J1402 pressures, and SAE 100R5 Minimum Bend Radius at SAE 100R5 working pressures. Refer to the latest Ryco Digital Crimp Tools for crimping parameters.

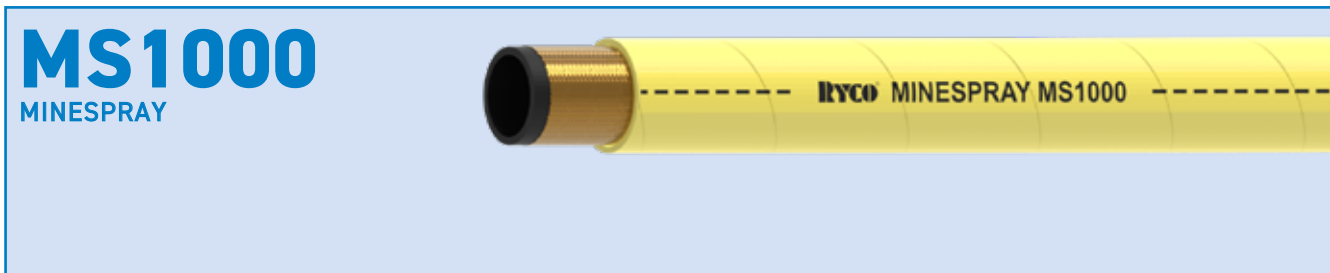

MS1000

MINESPRAY

RECOMMENDED FOR:

Water and air spray suited for dust control in all industrial and mining applications.

TUBE:

Black, oil resistant synthetic rubber.
Cover is perforated (pin-pricked).

REINFORCEMENT:

One braid of high tensile steel wire.

COVER:

Yellow, oil resistant and abrasion resistant synthetic rubber.
No skiving required with T2000 Series Crimp Couplings.

MSHA - FLAME RESISTANCE:

Complies with Flame Resistant requirements of Australian Standard AS 2660 and Method of Test AS 1180.10B. Meets Flame Resistant Designation "U.S. MSHA" of the US Department of Labor, Mine Safety and Health Administration.

TEMPERATURE RANGE:

From -40°C to +100°C (-40°F to +212°F).
For water, emulsions etc. see page 58.

WORKING PRESSURE:

Maximum working pressures are based on 4:1 safety factor (maximum working pressure to minimum burst pressure).

COUPLINGS:

NON-SKIVE ONE-PIECE CRIMP T2000 Series.

Assembly Instructions pages 146.

MS1000 - MINESPRAY															
PART NO	HOSE SIZE	NOMINAL HOSE ID		NOMINAL HOSE OD		MAXIMUM WORKING PRESSURE		MINIMUM BURST PRESSURE		MINIMUM BEND RADIUS		AVERAGE WEIGHT		COUPLING SERIES ONE PIECE	
Hose	DN	Dash	mm	inch	mm	inch	bar	psi	bar	psi	mm	inch	kg/m	lb/ft	NON-SKIVE
MS1008	12	-08	13,0	1/2	18,5	0.73	70	1000	280	4000	90	3.6	0,29	0.19	T2000
MS1010	16	-10	16,2	5/8	22,1	0.87	70	1000	280	4000	100	3.9	0,35	0.24	T2000
MS1012	19	-12	19,1	3/4	25,8	1.02	70	1000	280	4000	120	4.7	0,40	0.27	T2000
MS1016	25	-16	25,4	1	32,5	1.28	70	1000	280	4000	150	5.9	0,62	0.42	T2000
MS1020	31	-20	31,8	1.1/4	39,5	1.56	70	1000	280	4000	210	8.3	0,75	0.50	T2000
MS1024	38	-24	38,1	1.1/2	46,0	1.81	70	1000	280	4000	250	9.9	1,00	0.67	T2000
MS1032	51	-32	50,8	2	59,1	2.33	70	1000	280	4000	300	11.8	1,42	0.95	T2000

Refer to the latest Ryco Digital Crimp Tools for crimping parameters.

HOSES

SPECIALTY AND HIGH TEMPERATURE

CS1000 COALSPRAY



RECOMMENDED FOR:

Water and air spray suited for dust control in all industrial and mining applications.

TUBE:

Black, oil resistant synthetic rubber.
Cover is perforated (pin-pricked).

REINFORCEMENT:

One braid of high tensile steel wire.

COVER:

Black, oil resistant and abrasion resistant synthetic rubber.
No skiving required with T2000 Series Crimp Couplings.

FRAS - FLAME RESISTANCE AND ANTI-STATIC:

Complies with Flame Resistant and Electrical Resistance (Anti-Static) requirements of Australian Standard AS 2660 and Methods of Test AS 1180.10B and 13A. Meets Flame Resistant Designation "U.S. MSHA" of the US Department of Labor, Mine Safety and Health Administration.

TEMPERATURE RANGE:

From -40°C to +100°C (-40°F to +212°F).
For water, emulsions etc. see page 58.

WORKING PRESSURE:

Maximum working pressures are based on 4:1 safety factor (maximum working pressure to minimum burst pressure).

COUPLINGS:

NON-SKIVE ONE-PIECE CRIMP

T2000 Series.

For water, emulsions etc. see page 58.

CS1000 - COALSPRAY															
PART NO	HOSE SIZE	NOMINAL HOSE ID		NOMINAL HOSE OD		MAXIMUM WORKING PRESSURE		MINIMUM BURST PRESSURE		MINIMUM BEND RADIUS		AVERAGE WEIGHT		COUPLING SERIES ONE PIECE	
Hose	DN	Dash	mm	inch	mm	inch	bar	psi	bar	psi	mm	inch	kg/m	lb/ft	NON-SKIVE
CS1008	12	-08	13,0	1/2	18,5	0.73	70	1000	280	4000	90	3.6	0,29	0.19	T2000
CS1010	16	-10	16,2	5/8	22,1	0.87	70	1000	280	4000	100	3.9	0,35	0.24	T2000
CS1012	19	-12	19,1	3/4	25,8	1.02	70	1000	280	4000	120	4.7	0,40	0.27	T2000
CS1016	25	-16	25,4	1	32,5	1.28	70	1000	280	4000	150	5.9	0,62	0.42	T2000
CS1020	31	-20	31,8	1.1/4	39,5	1.56	70	1000	280	4000	210	8.3	0,75	0.50	T2000
CS1024	38	-24	38,1	1.1/2	46,0	1.81	70	1000	280	4000	250	9.9	1,00	0.67	T2000
CS1032	51	-32	50,8	2	59,1	2.33	70	1000	280	4000	300	11.8	1,42	0.95	T2000

Refer to the latest Ryco Digital Crimp Tools for crimping parameters.



BIOTRANS

TRANSPORTING OUR FUTURE

WIDE RANGE OF FLUIDS

MULTI PURPOSE HOSE



MSHA

HOSES

SPECIALTY

BT1

ONE WIRE BRAID HOSE



RECOMMENDED FOR:

Marine fuel applications. Low pressure hydraulic oil return lines, general purpose water, glycol antifreeze solutions, biodiesel, diesel fuel, ethanol, gasoline/petrol or air.

PERFORMANCE:

Meets or Exceeds the Performance Requirements of: SAE J1527 Type Class I, USCG SAE J1942, SAE J30R2 (non-marine). Meets SAE J30R2 performance requirements for non-marine applications and SAE J1527 Type Class I and USCG SAEJ1942 for marine applications.

TUBE:

Black, oil resistant synthetic rubber.

REINFORCEMENT:

One braid of high tensile steel wire.

COVER:

Blue, oil resistant and abrasion resistant synthetic rubber.

MSHA - FLAME RESISTANCE:

Complies with Flame Resistant requirements of Australian Standard AS 2660 and Method of Test AS 1180.10B. Meets Flame Resistant Designation "U.S. MSHA" of the US Department of Labor, Mine Safety and Health Administration.

WORKING PRESSURE:

Maximum working pressures are based on 4:1 safety factor (maximum working pressure to minimum burst pressure).

TEMPERATURE RANGE:

MEDIA	TEMP °C	
	MIN	MAX
Petroleum based hydraulic fluids	-40	+100
Water, water/oil emulsion and water/glycol hydraulic fluids	—	70
Engine oil, lubricating oils	-40	100
Air	—	70
Diesel, JP8	-20	80
Biodiesel	-40	80
Gasoline/petrol	-20	80
Ethanol blends (15% max.ethanol)	-20	80

THIRD PARTY APPROVALS:

ABS, DNV-GL, LR, MED, USCG, DOT, GOST-R, BV, RINA and KR.

COUPLINGS:

NON-SKIVE ONE-PIECE CRIMP

T2000 Series (sizes -04 to -16).

Assembly Instructions pages 146.

FIELD ATTACHABLE NON-SKIVE

6000 Series insert (sizes -04 to -16).

K000 Series ferrule (sizes -04 to -16).

Assembly Instructions page 142.

BT1 - BIOTRANS		NOMINAL HOSE ID		NOMINAL HOSE OD		MAXIMUM WORKING PRESSURE		MINIMUM BURST PRESSURE		MINIMUM BEND RADIUS		AVERAGE WEIGHT		COUPLING SERIES		
PART NO	HOSE SIZE	mm	inch	mm	inch	bar	psi	bar	psi	mm	inch	kg/m	lb/ft	ONE PC	FIELD ATT	
BT14	6	-04	6,6	1/4	13,3	0.52	50	725	200	2900	25	1.0	0,22	0.15	T2000	6000 (K000)
BT15	8	-05	8,2	5/16	14,9	0.59	50	725	200	2900	30	1.2	0,25	0.17	T2000	
BT16	10	-06	9,8	3/8	17,3	0.68	50	725	200	2900	35	1.4	0,31	0.21	T2000	6000 (K000)
BT18	12	-08	13,0	1/2	20,3	0.80	50	725	200	2900	55	2.2	0,39	0.26	T2000	6000 (K000)
BT110	16	-10	16,2	5/8	23,6	0.93	50	725	200	2900	70	2.8	0,49	0.33	T2000	6000 (K000)
BT112	19	-12	19,1	3/4	27,6	1.09	50	725	200	2900	80	3.2	0,62	0.41	T2000	6000 (K000)
BT116	25	-16	25,4	1	35,5	1.40	50	725	200	2900	105	4.1	0,90	0.60	T2000	6000 (K000)

Refer to the latest Ryco Digital Crimp Tools for crimping parameters.

SW

VERY HIGH PRESSURE WATERBLAST



INTRODUCTION

HOSES

TECHNICAL

RECOMMENDED FOR:

Very High Pressure waterblast hose for the cleaning and preparation of marine surfaces, runway and swimming pool cleaning, and paint removal.

DO NOT USE with Steam.

TUBE:

Oil and water resistant synthetic rubber.

REINFORCEMENT:

Four alternating layers of spiralled high tensile steel wire.

COVER:

Oil, water and ozone resistant synthetic rubber. The cover is formulated to resist marking. Internal and External skiving required with TW4000 Series Interlok Crimp Couplings.

FEATURES:

Exceeds ISO 7751 performance requirements.
Meets specifications EN 1829-2 (impulse) and AS/NZS 4233.2.
Highly abrasion resistant cover.

TEMPERATURE RANGE:

Continuous service from -20°C to +80°C (-4°F to +176°F).
Intermittent service to +100°C (+212°F).

WORKING PRESSURE:

Maximum working pressures are based on 2.5:1 safety factor (maximum working pressure to minimum burst pressure).

COUPLINGS:

INTERLOK SKIVE ONE-PIECE CRIMP

TW4000 Series (Sizes -06 to -16) page 325.
Assembly Instructions page 481

A MEMBER OF:

The Waterjet Technology Association (WJTA) and Industrial & Municipal Cleaning Association (IMCA)

The Australasian High Pressure Water Jetting Association

SW - SHOCKWAVE																
COLOUR CODE	PART NO	HOSE SIZE	NOMINAL HOSE ID		NOMINAL HOSE OD		MAXIMUM WORKING PRESSURE		MINIMUM BURST PRESSURE		MINIMUM BEND RADIUS		AVERAGE WEIGHT		COUPLING SERIES INTERLOK ONE-PIECE	
	Hose	DN	Dash	mm	inch	mm	inch	bar	psi	bar	psi	mm	inch	kg/m	lb/ft	INT/EXT SKIVE
	SW18006	10	-06	9,5	3/8	21,5	0.85	1250	18125	3125	45315	150	5.9	0,56	0.37	TW4000
	SW16008	12	-08	12,7	1/2	24,6	0.97	1100	16000	2750	40000	180	7.1	0,83	0.56	TW4000
	SW14512	19	-12	19,0	3/4	31,9	1.26	1000	14500	2500	36250	220	8.7	0,92	0.62	TW4000
	SW10012	19	-12	19,0	3/4	30,6	1.21	700	10000	1750	25000	220	8.7	1,34	0.90	TW4000
	SW10016	25	-16	25,4	1	37,6	1.48	700	10000	1750	25000	250	9.8	1,39	0.93	TW4000

Refer to the latest Ryco Digital Crimp Tools for crimping parameters.

WJTA-IMCA colour code recommendations:	
	20K Pressure Range
	15K Pressure Range
	10K Pressure Range

HOSES

PRESSURE WASHER

JS4000/G

PRESSURE WASHER
280 BAR/4100 PSI



RECOMMENDED FOR:

Hot Water Pressure Washer Machines.

DO NOT USE with Steam.

PERFORMANCE:

Meets or Exceeds the Performance Requirements of:
EN 1829-2.

TUBE:

Black, heat resistant synthetic rubber.

REINFORCEMENT:

One braid of high tensile steel wire.

COVER:

Oil resistant synthetic rubber formulated to resist marking.

JS4000, black, highly abrasion resistant (AR), non marking.

JS4000G, grey, animal fat resistant (AFR), non marking.

Embossed layline for positive, permanent identification.

No skiving required for T2000 Series Crimp Couplings.

TEMPERATURE RANGE:

JS4000/G JETSTORM Hoses handle hot water up to
+135°C (+275°F) with intermittent service to
+150°C (+302°F).

WORKING PRESSURE:

Maximum working pressures are based on 3:1 safety factor
(maximum working pressure to minimum burst pressure).

COUPLINGS:

NON-SKIVE ONE-PIECE CRIMP

T2000 Series (sizes -04 to -08).

Assembly Instructions pages 146.

A MEMBER OF:

The Waterjet Technology Association (WJTA) and Industrial
& Municipal Cleaning Association (IMCA)

The Australasian High Pressure Water Jetting Association

JS4000 - JETSTORM															
PART NO	HOSE SIZE	NOMINAL HOSE ID		NOMINAL HOSE OD		MAXIMUM WORKING PRESSURE		MINIMUM BURST PRESSURE		MINIMUM BEND RADIUS		AVERAGE WEIGHT		COUPLING SERIES ONE PIECE	
Hose	DN	Dash	mm	inch	mm	inch	bar	psi	bar	psi	mm	inch	kg/m	lb/ft	NON-SKIVE
JS4004/G	6	-04	6,6	1/4	11,5	0.45	280	4100	840	12300	50	2.0	0,15	0.10	T2000
JS4005/G	8	-05	8,2	5/16	13,1	0.52	280	4100	840	12300	55	2.2	0,18	0.12	T2000
JS4006/G	10	-06	9,8	3/8	15,3	0.60	280	4100	840	12300	65	2.6	0,23	0.15	T2000
JS4008/G	12	-08	13,0	1/2	18,3	0.72	280	4100	840	12300	90	3.6	0,31	0.21	T2000

Refer to the latest Ryco Digital Crimp Tools for crimping parameters.



JS4000BX/GX

PRESSURE WASHER
280 BAR/4100 PSI

RECOMMENDED FOR:
Hot Water Pressure Washer Machines.
DO NOT USE with Steam.

PERFORMANCE:
Meets or Exceeds the Performance Requirements of:
EN 1829-2.

TUBE:
Black, heat resistant synthetic rubber.

REINFORCEMENT:
One braid of high tensile steel wire.

COVER:
Oil resistant synthetic rubber formulated to resist marking
.JS4000BX, blue, highly abrasion resistant (AR), non marking
JS4000GX, grey, highly abrasion resistant (AR), non marking.
Embossed layline for positive, permanent identification.
No skiving required for T2000 Series Crimp Couplings.

TEMPERATURE RANGE:
JS4000BX/GX JETSTORM Hoses handle hot water up to
+135°C (+275°F) with intermittent service to
+150°C (+302°F).

WORKING PRESSURE:
Maximum working pressures are based on 3:1 safety factor
(maximum working pressure to minimum burst pressure).

COUPLINGS:
NON-SKIVE ONE-PIECE CRIMP
T2000 Series (sizes -04 to -08).
Assembly Instructions pages 146.

A MEMBER OF:
The Waterjet Technology Association (WJTA) and Industrial
& Municipal Cleaning Association (IMCA)
The Australasian High Pressure Water Jetting Association

JS4000 - JETSTORM															
PART NO	HOSE SIZE	NOMINAL HOSE ID		NOMINAL HOSE OD		MAXIMUM WORKING PRESSURE		MINIMUM BURST PRESSURE		MINIMUM BEND RADIUS		AVERAGE WEIGHT		COUPLING SERIES ONE PIECE	
Hose	DN	Dash	mm	inch	mm	inch	bar	psi	bar	psi	mm	inch	kg/m	lb/ft	NON-SKIVE
JS4004BX	6	-04	6,6	1/4	12,6	0.50	280	4100	840	12300	50	2.0	0,18	0.12	T2000
JS4005BX	8	-05	8,2	5/16	14,2	0.56	280	4100	840	12300	55	2.2	0,22	0.15	T2000
JS4006BX	10	-06	9,8	3/8	16,4	0.65	280	4100	840	12300	65	2.6	0,26	0.17	T2000
JS4008BX	12	-08	13,0	1/2	19,4	0.76	280	4100	840	12300	90	3.6	0,36	0.24	T2000
JS4004GX	6	-04	6,6	1/4	12,6	0.50	280	4100	840	12300	50	2.0	0,18	0.12	T2000
JS4005GX	8	-05	8,2	5/16	14,2	0.56	280	4100	840	12300	55	2.2	0,22	0.15	T2000
JS4006GX	10	-06	9,8	3/8	16,4	0.65	280	4100	840	12300	65	2.6	0,26	0.17	T2000
JS4008GX	12	-08	13,0	1/2	19,4	0.76	280	4100	840	12300	90	3.6	0,36	0.24	T2000

Refer to the latest Ryco Digital Crimp Tools for crimping parameters.

HOSES

PRESSURE WASHER

JS6000/G

PRESSURE WASHER
420 BAR/6100 PSI



RECOMMENDED FOR:

Hot Water Pressure Washer Machines.

DO NOT USE with Steam.

PERFORMANCE:

Meets or Exceeds the Performance Requirements of:
EN 1829-2.

TUBE:

Black, heat resistant synthetic rubber.

REINFORCEMENT:

Two braid of high tensile steel wire.

COVER:

Oil resistant synthetic rubber formulated to resist marking.

JS6000, black, highly abrasion resistant (AR), non marking
JS6000G, grey, animal fat resistant (AFR), non marking.

Embossed layline for positive, permanent identification.

No skiving required for T2000 Series Crimp Couplings.

TEMPERATURE RANGE:

JS6000/G JETSTORM Hoses handle hot water up to
+135°C (+275°F) with intermittent service to
+150°C (+302°F).

WORKING PRESSURE:

Maximum working pressures are based on 3:1 safety factor
(maximum working pressure to minimum burst pressure).

COUPLINGS:

NON-SKIVE ONE-PIECE CRIMP

T2000 Series (sizes -04 to -08).

Assembly Instructions pages 146.

A MEMBER OF:

The Waterjet Technology Association (WJTA) and Industrial &
Municipal Cleaning Association (IMCA)

The Australasian High Pressure Water Jetting Association

JS6000 - JETSTORM															
PART NO	HOSE SIZE	NOMINAL HOSE ID		NOMINAL HOSE OD		MAXIMUM WORKING PRESSURE		MINIMUM BURST PRESSURE		MINIMUM BEND RADIUS		AVERAGE WEIGHT		COUPLING SERIES ONE PIECE	
Hose	DN	Dash	mm	inch	mm	inch	bar	psi	bar	psi	mm	inch	kg/m	lb/ft	NON-SKIVE
JS6004/G	6	-04	6,6	1/4	12,4	0.49	420	6100	1260	18300	50	2.0	0,23	0.15	T2000
JS6005/G	8	-05	8,2	5/16	14,5	0.57	420	6100	1260	18300	55	2.2	0,30	0.20	T2000
JS6006/G	10	-06	9,8	3/8	16,3	0.64	420	6100	1260	18300	65	2.6	0,32	0.22	T2000
JS6008/G	12	-08	13,0	1/2	19,3	0.76	420	6100	1260	18300	90	3.6	0,44	0.30	T2000

Refer to the latest Ryco Digital Crimp Tools for crimping parameters.

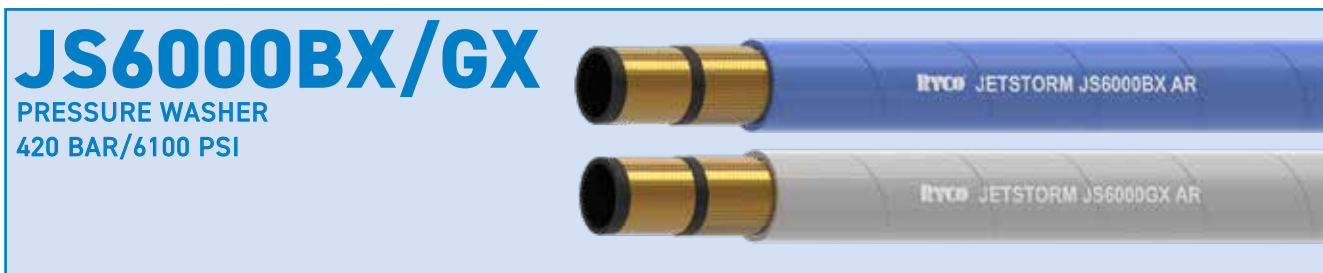

JS6000BX/GX

PRESSURE WASHER
420 BAR/6100 PSI

RECOMMENDED FOR:

Hot Water Pressure Washer Machines.

DO NOT USE with Steam.

PERFORMANCE:

Meets or Exceeds the Performance Requirements of:
EN 1829-2.

TUBE:

Black, heat resistant synthetic rubber.

REINFORCEMENT:

Two braid of high tensile steel wire.

COVER:

Oil resistant synthetic rubber formulated to resist marking.
JS6000BX, blue, highly abrasion resistant (AR), non marking.
JS6000GX, grey, highly abrasion resistant (AR), non marking.
Embossed layline for positive, permanent identification.
No skiving required for T2000 Series Crimp Couplings.

TEMPERATURE RANGE:

JS6000BX/GX JETSTORM Hoses handle hot water up to
+135°C (+275°F) with intermittent service to
+150°C (+302°F).

WORKING PRESSURE:

Maximum working pressures are based on 3:1 safety factor
(maximum working pressure to minimum burst pressure).

COUPLINGS:

NON-SKIVE ONE-PIECE CRIMP
T2000 Series (sizes -04 to -08).
Assembly Instructions pages 146.

A MEMBER OF:

The Waterjet Technology Association (WJTA) and Industrial
& Municipal Cleaning Association (IMCA)
The Australasian High Pressure Water Jetting Association

JS6000BX/GX - JETSTORM															
PART NO	HOSE SIZE		NOMINAL HOSE ID		NOMINAL HOSE OD		MAXIMUM WORKING PRESSURE		MINIMUM BURST PRESSURE		MINIMUM BEND RADIUS		AVERAGE WEIGHT		COUPLING SERIES ONE PIECE
Hose	DN	Dash	mm	inch	mm	inch	bar	psi	bar	psi	mm	inch	kg/m	lb/ft	NON-SKIVE
JS6004BX	6	-04	6,6	1/4	13,5	0.53	420	6100	1260	18300	50	2.0	0,26	0.17	T2000
JS6005BX	8	-05	8,2	5/16	15,6	0.61	420	6100	1260	18300	55	2.2	0,34	0.23	T2000
JS6006BX	10	-06	9,8	3/8	17,4	0.69	420	6100	1260	18300	65	2.6	0,35	0.24	T2000
JS6008BX	12	-08	13,0	1/2	20,4	0.80	420	6100	1260	18300	90	3.6	0,49	0.33	T2000
JS6004GX	6	-04	6,6	1/4	13,5	0.53	420	6100	1260	18300	50	2.0	0,26	0.17	T2000
JS6005GX	8	-05	8,2	5/16	15,6	0.61	420	6100	1260	18300	55	2.2	0,34	0.23	T2000
JS6006GX	10	-06	9,8	3/8	17,4	0.69	420	6100	1260	18300	65	2.6	0,35	0.24	T2000
JS6008GX	12	-08	13,0	1/2	20,4	0.80	420	6100	1260	18300	90	3.6	0,49	0.33	T2000

Refer to the latest Ryco Digital Crimp Tools for crimping parameters.

HOSES

SUCTION & RETURN

SRF/P

COMPACT
SUCTION & RETURN HOSE



RECOMMENDED FOR:

Petroleum and water base hydraulic fluids in suction lines or in low pressure return lines. Small bend radius is an advantage in installations where space is minimal.

PERFORMANCE:

Meets or Exceeds the Performance Requirements of: AS 3791 100R4, SAE J517 100R4.

TUBE:

Black, oil resistant synthetic rubber.

REINFORCEMENT:

Textile reinforcement with spiral wire to prevent collapsing.

COVER:

Black, oil resistant and abrasion resistant synthetic rubber.

TEMPERATURE RANGE:

From -40°C to +100°C (-40°F to +212°F).

WORKING PRESSURE:

Maximum working pressures are based on 4:1 safety factor (maximum working pressure to minimum burst pressure).

COUPLINGS:

NON-SKIVE ONE-PIECE CRIMP

T4000 Series (Sizes -12 to -48).

Assembly Instructions pages 146.

NON-SKIVE TWO-PIECE CRIMP

MF Series +M03400 Ferrule (Sizes -56 to -64).

SRF/P - DEFIANT																	
PART NO	HOSE SIZE	NOMINAL HOSE ID		NOMINAL HOSE OD		MAXIMUM WORKING PRESSURE		MINIMUM BURST PRESSURE		MINIMUM BEND RADIUS		VACUUM RATING		AVERAGE WEIGHT		COUPLING SERIES ONE PIECE	
Hose	DN	Dash	mm	inch	mm	inch	bar	psi	bar	psi	mm	inch	mmHg	inHg	kg/m	lb/ft	NON-SKIVE
SRFP12	19	-12	19,1	3/4	29,6	1.16	21	300	84	1200	65	2.5	635	25	0,53	0.36	T4000
SRFP16	25	-16	25,4	1	36,0	1.41	17	250	68	1000	75	2.9	635	25	0,67	0.45	T4000
SRFP20	31	-20	31,8	1.1/4	42,6	1.67	14	200	56	800	100	3.9	635	25	0,82	0.55	T4000
SRFP24	38	-24	38,1	1.1/2	49,4	1.94	11	150	42	600	125	4.9	635	25	1,04	0.70	T4000
SRFP32	51	-32	50,8	2	62,4	2.45	7	100	28	400	150	5.9	635	25	1,41	0.95	T4000
SRFP40	63	-40	63,5	2.1/2	76,7	3.01	4	60	17	240	235	9.25	635	25	2,35	1.58	T4000
SRFP48	76	-48	76,2	3	88,6	3.48	4	60	17	240	300	11.81	635	25	2,70	1.82	T4000
SRFP56	89	-56	88,9	3.1/2	103,9	4.09	3	40	12	170	350	13.78	635	25	3,42	2.30	MF + M03400-56
SRFP64	102	-64	101,6	4	116,4	4.58	3	40	12	170	400	15.75	635	25	3,98	2.68	MF + M03400-64

PART NO	CLAMP PART NO	CLAMP ADJUSTMENT RANGE	RECOMMENDED TIGHTENING TORQUE	
		d mm	N.m	ft.lbf
SRFP12	RSC-3134	31 to 34	20	15
SRFP16	RSC-3740*	37 to 40	20	15
	RSC-4043*	40 to 43	20	15
SRFP20	RSC-4347*	43 to 47	20	15
	RSC-4751*	47 to 51	20	15
SRFP24	RSC-5155	51 to 55	20	15
SRFP32	RSC-6368	63 to 68	25	18

NOTE: For sizes -20, -24 & -32, use **Ryco SRF** Hose.

*Due to the manufacturing tolerance on outside diameter of the hose and the range of adjustment of the clamp, it is necessary to confirm correct clamp at time of assembly.

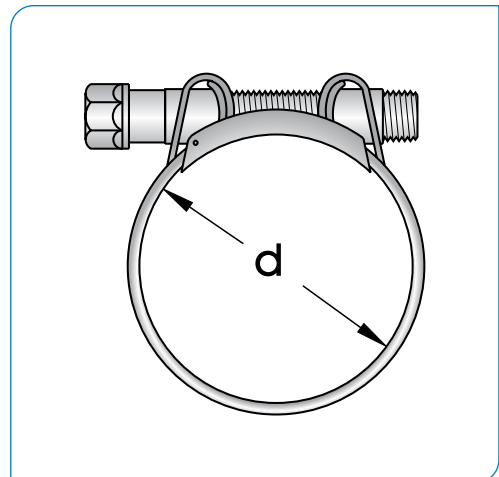

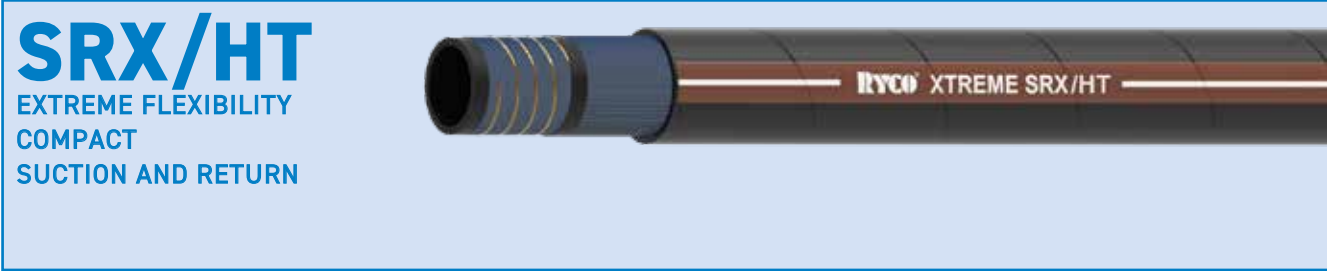

SRX/HT

EXTREME FLEXIBILITY
COMPACT
SUCTION AND RETURN

RECOMMENDED FOR:

Petroleum and water base hydraulic fluids in suction lines or in low pressure return lines. Extreme Flexibility is an advantage in installations where space is minimal.

PERFORMANCE:

Meets or Exceeds the Performance Requirements of: AS 3791 100R4, SAE J517 100R4.

TUBE:

Black, oil resistant synthetic rubber.

REINFORCEMENT:

Textile reinforcement with spiral wire to prevent collapsing.

COVER:

Black, oil resistant and abrasion resistant synthetic rubber.

TEMPERATURE RANGE:

From -40°C to +135°C (-40°F to +275°F)

WORKING PRESSURE:

Maximum working pressures are based on 4:1 safety factor (maximum working pressure to minimum burst pressure).

COUPLINGS:

NON-SKIVE ONE-PIECE CRIMP

T4000 Series (Sizes -12 to -48).
Assembly Instructions pages 146.

NON-SKIVE TWO-PIECE CRIMP

MF Series + MO3400 Ferrule (Sizes -12 to -64).

SRX/HT - XTREME																			
PART NO	HOSE SIZE	NOMINAL HOSE ID		NOMINAL HOSE OD		MAXIMUM WORKING PRESSURE		MINIMUM BURST PRESSURE		MINIMUM BEND RADIUS				VACUUM RATING		AVERAGE WEIGHT		COUPLING SERIES ONE PIECE	
		mm	inch	mm	inch	bar	psi	bar	psi	-20°C		-40°C		mmHg	inHg	kg/m	lb/ft		
Hose	DN	Dash	mm	inch	mm	inch	bar	psi	bar	psi	mm	inch	mm	inch	mmHg	inHg	kg/m	lb/ft	NON-SKIVE
SRXHT12	19	-12	19,1	3/4	29,6	1.16	25	360	100	1,450	40	1.6	80	3.2	635	25	0,53	0.36	T4000
SRXHT16	25	-16	25,4	1	36,0	1.41	25	360	100	1,450	45	1.8	100	3.9	635	25	0,67	0.45	T4000
SRXHT20	31	-20	31,8	1.1/4	43,0	1.69	17	250	70	1,010	60	2.4	130	5.1	635	25	0,83	0.56	T4000
SRXHT24	38	-24	38,1	1.1/2	49,6	1.95	17	250	70	1,010	65	2.6	170	6.7	635	25	1,10	0.74	T4000
SRXHT32	51	-32	50,8	2	62,4	2.45	10	150	42	600	100	3.9	200	7.9	635	25	1,41	0.95	T4000
SRXHT40	63	-40	63,5	2.1/2	75,7	2.98	10	150	42	600	140	5.5	235	9.3	635	25	2,24	1.51	T4000
SRXHT48	76	-48	76,2	3	88,2	3.47	7	100	28	400	180	7.1	300	11.8	635	25	2,70	1.82	T4000
SRXHT56	89	-56	88,9	3.1/2	103,5	4.07	5	70	21	304	210	8.3	350	13.77	635	25	3,61	2.43	MF + M03400-56
SRXHT64	102	-64	101,6	4	116,6	4.59	5	70	21	304	250	9.8	400	15.74	635	25	4,21	2.83	MF + M03400-64

Refer to the latest Ryco Digital Crimp Tools for crimping parameters.

RTH1

STAINLESS STEEL
BRAID TEFLON* HOSE



RECOMMENDED FOR:

High pressure hydraulic oil lines. Fluids at extremes of pressure and temperature. Ryco RTH1 Series Hose Lining is chemically pure, inert and contains no leachable additives. Ryco RTH1 is remarkably resistant to high temperature and flame. It has a very high melting point, thermal degradation threshold and auto-ignition temperature. Warning: RTH1 Hose Liner is non-conductive. Do not use with high velocity fluids and gases, as static electricity may be generated and cause premature failure of hose. If in doubt contact Ryco Hydraulics technical department.

PERFORMANCE:

Meets or Exceeds the Performance Requirements of: SAE 100R14. RTH12 meets ID and OD requirements of SAE 100R14. Other sizes have ID and OD different to SAE 100R14.

TUBE:

TEFLON® (PTFE).

REINFORCEMENT:

One braid of high tensile Grade 304 stainless steel wire.

TEMPERATURE RANGE:

From -60°C to +260°C (-76°F to +500°F).
(According to application).
For water, emulsions etc. see page 58.

WORKING TEMPERATURE		% OF WORKING PRESSURE THAT MAY BE USED SAFELY
°C	°F	Percentage
-60°C to +100°C	(-76°F to +212°F)	100
+101°C to +150°C	(+214°F to +302°F)	93
+151°C to +200°C	(+304°F to +392°F)	85
+201°C to +250°C	(+394°F to +482°F)	77
+251°C to +260°C	(+484°F to +500°F)	70

WORKING PRESSURE:

Maximum working pressures are based on 4:1 safety factor (maximum working pressure to minimum burst pressure).

THIRD PARTY APPROVALS:

ABS, DNV-GL, LR, MED, USCG, DOT, GOST-R, BV, RINA and KR.

COUPLINGS:

ONE-PIECE CRIMP

TT000 Series (sizes -04 to -16).
Assembly instructions page 482.

RTH1																	
PART NO	HOSE SIZE	NOMINAL HOSE ID		NOMINAL HOSE OD		MAXIMUM WORKING PRESSURE		MAXIMUM WORKING PRESSURE		MINIMUM BURST PRESSURE		MINIMUM BEND RADIUS		AVERAGE WEIGHT		COUPLING SERIES ONE PIECE	
Hose	DN	Dash	mm	inch	mm	inch	bar	psi	bar	psi	bar	psi	mm	inch	kg/m	lb/ft	
RTH14	6	-04	6,4	1/4	9,4	0.37	170	2450	105	1500	680	9800	75	3.0	0,12	0.08	TT000
RTH16	10	-06	9,5	3/8	11,7	0.46	165	2375	105	1500	660	9500	125	5.0	0,14	0.09	TT000
RTH18	12	-08	12,7	1/2	15,4	0.61	120	1750	56	800	485	7000	140	5.5	0,22	0.15	TT000
RTH110	16	-10	15,9	5/8	18,4	0.72	105	1500	56	800	420	6000	165	6.5	0,28	0.19	TT000
RTH112	19	-12	19,1	3/4	22,1	0.87	85	1250	56	800	345	5000	200	8.0	0,33	0.22	TT000
RTH116	25	-16	25,4	1	28,6	1.13	55	800	56	800	220	3200	300	12.0	0,46	0.31	TT000

* DuPont Registered TM
Refer to the latest Ryco Digital Crimp Tools for crimping parameters.

PL1D

EXTRA ABRASION RESISTANT
FRAS
ONE TEXTILE BRAID HOSE
PUSH ON HOSE



RECOMMENDED FOR:

Petroleum base hydraulic oils, glycol antifreeze solutions, water, diesel fuels, and air.

PERFORMANCE:

Meets or Exceeds the Performance Requirements of: AS 3791 100R6, DIN 20021-1TE, ISO 4079 Type R6, SAE 100R6.

TUBE:

Black, oil resistant synthetic rubber.

REINFORCEMENT:

One textile braid.

COVER:

DIEHARD™ Black, oil and extra abrasion resistant synthetic rubber. Flame Resistant, Anti-Static (FRAS) & MSHA compliant. No skiving required with T4000 Series Crimp Couplings.

FRAS - FLAME RESISTANCE AND ANTI-STATIC:

DIEHARD™ FRAS textile braided hose meets or exceeds the Flame Resistance of U.S.A. MSHA Code of Federal Regulations Title 30 Part 18 Section 18.65 and the Anti-Static requirements of MDG 41, AS1180-13A and ISO 8031 having a resistance of less than 1MΩ per metre.

TEMPERATURE RANGE:

From -40°C to +100°C (-40°F to +212°F).
For water, emulsions etc. see page 58.

WORKING PRESSURE:

Maximum working pressures are based on 4:1 safety factor (maximum working pressure to minimum burst pressure). PL1D Hose, and 8000 Series Push-On Fittings, are recommended for use in systems with Static Working Pressures (constant loads without pressure spikes) only. They are not recommended for vibration or pressure surge applications. PL1D Hose should not be used at both maximum working pressure and maximum temperature simultaneously.

COUPLINGS:

NON-SKIVE ONE-PIECE CRIMP

T4000 Series (Sizes -04 to -12).
Assembly Instructions pages 146.

FIELD ATTACHABLE NON-SKIVE

8000 Series Push-On (sizes -04 to -12).
PL1D Hose simply pushes on to 8000 Series Couplings. For diesel fuel and other potentially dangerous, or critical applications crimp fittings are required.

PL1D - DIEHARD																		
PART NO	HOSE SIZE	NOMINAL HOSE ID		NOMINAL HOSE OD		MAXIMUM STATIC WORKING PRESSURE		MINIMUM BURST PRESSURE		MINIMUM BEND RADIUS		VACUUM RATING		AVERAGE WEIGHT		COUPLING SERIES		
Hose	DN	Dash	mm	inch	mm	inch	bar	psi	bar	psi	mm	inch	mmHg	inHg	kg/m	lb/ft	NON-SKIVE	
PL14D	6	-04	6,6	1/4	12,7	0.50	30	435	120	1740	65	2.6	710	28	0,12	0.08	T4000	8000
PL15D	8	-05	8,2	5/16	14,3	0.56	30	435	120	1740	75	3.0	710	28	0,15	0.10	T4000	8000
PL16D	10	-06	9,8	3/8	15,9	0.63	30	435	120	1740	75	3.0	635	25	0,17	0.11	T4000	8000
PL18D	12	-08	13,0	1/2	19,8	0.78	30	435	120	1740	90	3.5	460	18	0,23	0.15	T4000	8000
PL110D	16	-10	16,2	5/8	23,0	0.91	26	375	104	1500	125	4.9	380	15	0,29	0.19	T4000	8000
PL112D	19	-12	19,1	3/4	26,4	1.04	22	320	88	1280	150	5.9	380	15	0,36	0.24	T4000	8000

Refer to the latest Ryco Digital Crimp Tools for crimping parameters.

HOSES

TEXTILE BRAID

PL1PV

FIRE RESISTANT UL94 V-0
ONE TEXTILE BRAID HOSE
PUSH ON HOSE



RECOMMENDED FOR:

Petroleum base hydraulic oils, glycol antifreeze solutions, water, diesel fuels, and air.

PERFORMANCE:

Meets or Exceeds the Performance Requirements of: AS 3791 100R6, ISO 4079 Type 1, SAE 100R6.

TUBE:

Black, oil resistant synthetic rubber.

REINFORCEMENT:

One textile braid.

COVER:

Black, oil and flame resistant synthetic rubber. Highly visible layline branding for easy and permanent identification. No skiving required with T4000 Series Crimp Couplings.

FLAME RESISTANCE:

Meets flame resistance requirements of UL94 V-0 - Standard for tests of flammability of plastic materials for parts and appliances. Certification No 20170622-E489804.

TEMPERATURE RANGE:

From -40°C to +100°C (-40°F to +212°F).
For water, emulsions etc. see page 58.

WORKING PRESSURE:

Maximum working pressures are based on 4:1 safety factor (maximum working pressure to minimum burst pressure). PL1PV Hose, and 8000 Series Push-On Fittings, are recommended for use in systems with Static Working Pressures (constant loads without pressure spikes) only. They are not recommended for vibration or pressure surge applications. PL1PV Hose should not be used at both maximum working pressure and maximum temperature simultaneously.

COUPLINGS:

NON-SKIVE ONE-PIECE CRIMP

T4000 Series (Sizes -04 to -12).
Assembly Instructions pages 146.

FIELD ATTACHABLE NON-SKIVE

8000 Series Push-On (sizes -04 to -12).
PL1PV Hose simply pushes on to 8000 Series Couplings. For diesel fuel and other potentially dangerous, or critical applications crimp fittings are required.

PL1 PV - PREVENTER																		
PART NO	HOSE SIZE	NOMINAL HOSE ID		NOMINAL HOSE OD		MAXIMUM STATIC WORKING PRESSURE		MINIMUM BURST PRESSURE		MINIMUM BEND RADIUS		VACUUM RATING		AVERAGE WEIGHT		ONE PC	PUSH ON	
Hose	DN	Dash	mm	inch	mm	inch	bar	psi	bar	psi	mm	inch	mmHg	inHg	kg/m	lb/ft	NON-SKIVE	
PL14PV	6	-04	6,6	1/4	12,7	0.50	30	410	112	1640	65	3.0	710	28	0,12	0.08	T4000	8000
PL15PV	8	-05	8,2	5/16	14,3	0.56	30	410	112	1640	75	3.0	710	28	0,15	0.10	T4000	8000
PL16PV	10	-06	9,8	3/8	15,9	0.63	30	410	112	1640	75	3.0	635	25	0,17	0.11	T4000	8000
PL18PV	12	-08	13,0	1/2	19,8	0.78	30	410	112	1640	100	5.0	460	18	0,23	0.15	T4000	8000
PL110PV	16	-10	16,2	5/8	23,0	0.91	26	350	96	1400	125	6.0	380	15	0,29	0.19	T4000	8000
PL112PV	19	-12	19,1	3/4	26,4	1.04	22	305	84	1220	150	6.9	380	15	0,36	0.24	T4000	8000

Refer to the latest Ryco Digital Crimp Tools for crimping parameters.

MP1

MULTI PURPOSE ONE TEXTILE BRAID HOSE



RECOMMENDED FOR:

Air, water, petroleum oils, kerosene and fuel oils.

PERFORMANCE:

Meets or Exceeds the Performance Requirements of:
RMA (USA) Class A High Oil Resistance (tube),
RMA (USA) Class B Medium Oil Resistance (cover),

TUBE:

Black, oil resistant synthetic rubber. RMA (USA) Class A High Oil Resistance.

REINFORCEMENT:

One textile braid.

COVER:

Red, oil resistant and abrasion resistant synthetic rubber (Modified Nitrile). RMA (USA) Class B Medium Oil Resistance. No skiving required with T4000 Series Crimp Couplings.

FEATURES:

Tube non-conductive at 1000 volts DC. Meets electrical resistance of one megohm per inch when subjected to 1000 volts DC. Incorrect storage and use may adversely affect electrical properties.

TEMPERATURE RANGE:

Air, water, petroleum & lubricating oils: -40°C to +93°C (-40°F to +200°F). Petrol, kerosene, fuel oils: -40°C to +49°C (-40°F to +120°F). For continuous service at upper temperature limit, reduce maximum working pressure by 30%. For water, emulsions etc. see page 58.

WORKING PRESSURE:

Maximum working pressures are based on 4:1 safety factor (maximum working pressure to minimum burst pressure), and are for the performance of the hose with Ryco T4000 Series One-Piece couplings only. Maximum working pressure for a hose assembly with other couplings depends on the type of coupling and the type of clamp used. MP1 Hose should not be used at maximum working pressure and maximum working temperature simultaneously.

COUPLINGS:

NON-SKIVE ONE-PIECE CRIMP

T4000 Series (Sizes -04 to -20).
Assembly Instructions pages 146.

Standard industrial hose barbed tails with hose clamps may also be suitable depending on working pressure required.

Not suitable for use with Ryco 8000 Series Push-On couplings.

MP1															
PART NO	HOSE SIZE	NOMINAL HOSE ID		NOMINAL HOSE OD		MAXIMUM WORKING PRESSURE		MINIMUM BURST PRESSURE		MINIMUM BEND RADIUS		AVERAGE WEIGHT		COUPLING SERIES ONE PIECE	
Hose	DN	Dash	mm	inch	mm	inch	bar	psi	bar	psi	mm	inch	kg/m	lb/ft	NON-SKIVE
MP14	6	-04	6,4	1/4	13,5	0.53	13,8	200	55,2	800	50	2.0	0,16	0.11	T4000
MP16	10	-06	9,5	3/8	17,5	0.69	13,8	200	55,2	800	70	3.0	0,24	0.16	T4000
MP18	12	-08	12,7	1/2	21,4	0.84	13,8	200	55,2	800	85	4.0	0,33	0.22	T4000
MP110	16	-10	15,9	5/8	25,4	1.00	13,8	200	55,2	800	105	5.0	0,43	0.29	T4000
MP112	19	-12	19,1	3/4	28,6	1.13	13,8	200	55,2	800	120	5.0	0,48	0.32	T4000
MP116	25	-16	25,4	1	37,3	1.47	13,8	200	55,2	800	155	8.0	0,82	0.55	T4000
MP120	31	-20	31,8	1.1/4	43,9	1.73	13,8	200	55,2	800	230	10.0	1,00	0.68	T4000

Refer to the latest Ryco Digital Crimp Tools for crimping parameters.



SPIDERLINE

KINK FREE FLEXIBILITY



TP7 & TP7T (SAE 100R7)



TP8 & TP8T (SAE 100R8)

COMPACT OUTSIDE
DIAMETER

REDUCED WEIGHT



ISOLATOR

THERMOPLASTIC HOSE

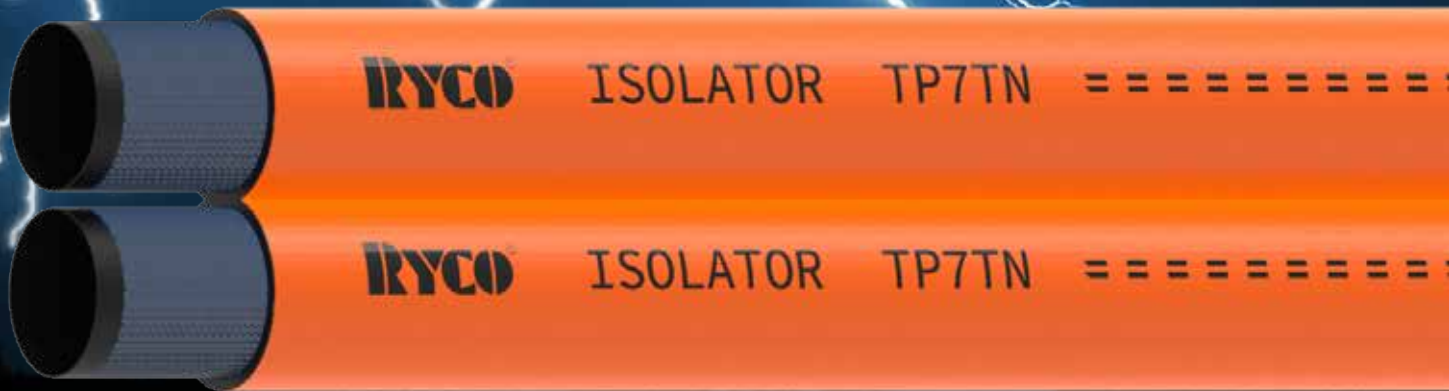

TP7N & TP7TN (SAE 100R7)



TP8N & TP8TN (SAE 100R8)

ELECTRICAL
NON-CONDUCTIVITY

COMPACT OUTSIDE
DIAMETER

REDUCED WEIGHT

HOSES

THERMOPLASTIC

TP7 SPIDERLINE R7 HOSE



RECOMMENDED FOR:

High pressure hydraulic oil lines; pilot lines; greasing and lubrication lines; and some pneumatic and water lines. Suitable for use with mineral, vegetable and most ester based hydraulic fluids. Suitable for use with some gases, fluids and chemicals. Cover is perforated (pin-pricked) for use with air and gases.

Ryco SPIDERLINE hose is lighter weight, has a more compact outside diameter and is less than half the minimum bend radius of wire braided rubber hose. Smooth inner tube for high flow rate; and smooth, easily cleaned cover.

The synthetic and aramid fibre reinforcement gives SPIDERLINE hose excellent corrosion and fatigue resistance plus low elongation at maximum dynamic working pressure.

PERFORMANCE:

Meets or Exceeds the Performance Requirements of: AS 3791 100R7, EN 855 TYPE R7, ISO 3949, SAE 100R7.

TUBE:

White, oil resistant seamless thermoplastic (Polyester).

REINFORCEMENT:

One or two braids of synthetic fibre.

COVER:

Black, oil and abrasion resistant thermoplastic (Polyurethane). Cover is perforated (pin-pricked).

TEMPERATURE RANGE:

From -40°C to +100°C (-40°F to +212°F).

Air & Water +70 °C (+158 °F).

For water, emulsions etc. see page 58.

WORKING PRESSURE:

Maximum working pressures are based on 4:1 safety factor (maximum working pressure to minimum burst pressure).

COUPLINGS:

NON-SKIVE ONE-PIECE CRIMP

TP000 Series (sizes -03 to -16).

Assembly Instructions pages 146.

TP7 - SPIDERLINE															
PART NO	HOSE SIZE	NOMINAL HOSE ID		NOMINAL HOSE OD		MAXIMUM WORKING PRESSURE		MINIMUM BURST PRESSURE		MINIMUM BEND RADIUS		AVERAGE WEIGHT		COUPLING SERIES ONE PIECE	
Hose	DN	Dash	mm	inch	mm	inch	bar	psi	bar	psi	mm	inch	kg/m	lb/ft	NON-SKIVE
TP73	5	-03	5,0	3/16	9,6	0.38	210	3000	840	12000	25	1.0	0,06	0.04	TP000
TP74	6	-04	6,5	1/4	12,2	0.48	210	3000	840	12000	35	1.4	0,10	0.07	TP000
TP75	8	-05	8,1	5/16	14,3	0.56	190	2700	760	10800	45	1.8	0,13	0.09	TP000
TP76	10	-06	9,7	3/8	16,0	0.63	160	2300	640	9200	55	2.2	0,15	0.10	TP000
TP78	12	-08	13,0	1/2	20,3	0.80	140	2000	560	8000	75	3.0	0,22	0.15	TP000
TP712	19	-12	19,5	3/4	27,1	1.07	90	1300	360	5200	140	5.5	0,34	0.23	TP000
TP716	25	-16	25,9	1	34,0	1.34	70	1000	280	4000	190	7.5	0,46	0.31	TP000

Refer to the latest Ryco Digital Crimp Tools for crimping parameters.



TP7N

**ISOLATOR
R7 NON CONDUCTIVE HOSE**

RECOMMENDED FOR:

Hydraulic oil lines where electrical non-conductivity is required (for use in applications where there is potential for contact with high voltage sources). Suitable for use with mineral, vegetable and most ester based hydraulic fluids. Heat and hydrolysis stabilised for use with water based hydraulic fluids up to +70°C (+158°F). Smooth inner tube for high flow rate; and smooth, easily cleaned cover. The high strength, non-metallic reinforcement gives these hoses excellent corrosion and fatigue resistance, and low elongation of ±2% at maximum dynamic working pressure.

PERFORMANCE:

Meets or Exceeds the Performance Requirements of: AS 3791 100R7, EN 855 TYPE R7, ISO 3949, SAE 100R7.

TUBE:

White, oil resistant seamless thermoplastic (Polyester).

REINFORCEMENT:

One or two braids of synthetic fibre.

COVER:

Orange, oil and abrasion resistant thermoplastic (Polyurethane). Cover is non-perforated.

FEATURES:

Meets non-conductivity requirements of SAE 100R7, AS 3791 100R7, EN 855 Type 7 (maximum leakage does not exceed 50 µA when subjected to 75 kV/305 mm or 250 kV/m for 5 minutes). Incorrect storage and use, particularly that leading to oil or moisture entering the reinforcement, may adversely affect electrical properties.

TEMPERATURE RANGE:

From -40°C to +100°C (-40°F to +212°F).
Air & Water +70 °C (+158 °F).
For water, emulsions etc. see page 58.

WORKING PRESSURE:

Maximum working pressures are based on 4:1 safety factor (maximum working pressure to minimum burst pressure).

COUPLINGS:

NON-SKIVE ONE-PIECE CRIMP

TP000 Series (sizes -04 to -16).
Assembly Instructions pages 146.

TP7N - ISOLATOR															
PART NO	HOSE SIZE	NOMINAL HOSE ID		NOMINAL HOSE OD		MAXIMUM WORKING PRESSURE		MINIMUM BURST PRESSURE		MINIMUM BEND RADIUS		AVERAGE WEIGHT		COUPLING SERIES ONE PIECE	
Hose	DN	Dash	mm	inch	mm	inch	bar	psi	bar	psi	mm	inch	kg/m	lb/ft	NON-SKIVE
TP74N	6	-04	6,5	1/4	12,2	0.48	210	3000	840	12000	35	1.4	0,10	0.07	TP000
TP76N	10	-06	9,7	3/8	16,0	0.63	160	2300	640	9200	55	2.2	0,15	0.10	TP000
TP78N	12	-08	13,0	1/2	20,3	0.80	140	2000	560	8000	75	3.0	0,22	0.15	TP000
TP712N	19	-12	19,5	3/4	27,1	1.07	90	1300	360	5200	140	5.5	0,34	0.23	TP000
TP716N	25	-16	25,9	1	34,0	1.34	70	1000	280	4000	190	7.5	0,46	0.31	TP000

Refer to the latest Ryco Digital Crimp Tools for crimping parameters.

HOSES

THERMOPLASTIC

TP7T

SPIDERLINE
R7 TWIN HOSE



RECOMMENDED FOR:

Ryco TP7T SPIDERLINE TWIN Hose consists of two TP7 Series Hoses of the same size, permanently joined together in a flat compact form that can be easily reeled onto payout and return reels on forklifts and cranes. It is also used on dispensing equipment and other applications requiring two hoses.

High pressure hydraulic oil lines; pilot lines; greasing and lubrication lines; and some pneumatic and water lines. Suitable for use with mineral, vegetable and most ester based hydraulic fluids. Suitable for use with some gases, fluids and chemicals. Cover is perforated (pin-pricked) for use with air and gases.

Ryco SPIDERLINE hose is lighter weight, has a more compact outside diameter and is less than half the minimum bend radius of wire braided rubber hose. Smooth inner tube for high flow rate; and smooth, easily cleaned cover.

The synthetic and aramid fibre reinforcement gives SPIDERLINE hose excellent corrosion and fatigue resistance plus low elongation at maximum dynamic working pressure.

PERFORMANCE:

Meets or Exceeds the Performance Requirements of: AS 3791 100R7, EN 855 TYPE R7, ISO 3949, SAE 100R7.

TUBE:

White, oil resistant seamless thermoplastic (Polyester).

REINFORCEMENT:

One or two braids of synthetic fibre.

COVER:

Black, oil and abrasion resistant thermoplastic (Polyurethane). Cover is perforated (pin-pricked).

TEMPERATURE RANGE:

From -40°C to +100°C (-40°F to +212°F).

Air & Water +70 °C (+158 °F).

For water, emulsions etc. see page 58.

WORKING PRESSURE:

Maximum working pressures are based on 4:1 safety factor (maximum working pressure to minimum burst pressure).

COUPLINGS:

NON-SKIVE ONE-PIECE CRIMP

TP000 Series (sizes -04 to -16).

Assembly Instructions pages 146.

TP7T - SPIDERLINE		NOMINAL HOSE ID		NOMINAL HOSE OD		MAXIMUM WORKING PRESSURE		MINIMUM BURST PRESSURE		MINIMUM BEND RADIUS		AVERAGE WEIGHT		COUPLING SERIES ONE PIECE	
PART NO	HOSE SIZE	mm	inch	mm	inch	bar	psi	bar	psi	mm	inch	kg/m	lb/ft	NON-SKIVE	
TP74T	6	-04	6,5	1/4	12,2	0.48	210	3000	840	12000	35	1.4	0,20	0.13	TP000
TP75T	8	-05	8,1	5/16	14,3	0.56	190	2700	760	10800	45	1.8	0,26	0.18	TP000
TP76T	10	-06	9,7	3/8	16,0	0.63	160	2300	640	9200	55	2.2	0,30	0.20	TP000
TP78T	12	-08	13,0	1/2	20,3	0.80	140	2000	560	8000	75	3.0	0,44	0.30	TP000

Refer to the latest Ryco Digital Crimp Tools for crimping parameters.

TP7TN

**ISOLATOR
R7 NON CONDUCTIVE
TWIN HOSE**

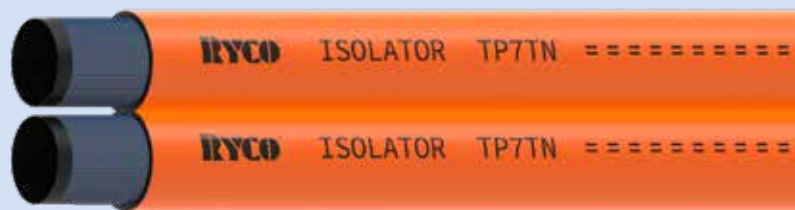

INTRODUCTION

HOSES

TECHNICAL

RECOMMENDED FOR:

Ryco TP7TN ISOLATOR TWIN Hose consists of two TP7N Series Hoses of the same size, permanently joined together in a flat compact form that can be easily reeled onto payout and return reels on forklifts and cranes. It is also used for hydraulic powered hand tools, such as loppers and chain saws, and other applications requiring two hoses. TP7TN is used where electrical non-conductivity is required (for use in applications where there is potential for contact with high voltage sources). Suitable for use with mineral, vegetable and most ester based hydraulic fluids. Heat and hydrolysis stabilised for use with water based hydraulic fluids up to +70°C (+158°F). Suitable for use with some gases, fluids and chemicals (contact Ryco Hydraulics Technical Department). Smooth inner tube for high flow rate; and smooth, easily cleaned cover. The polyester reinforcement gives TP7TN Hose excellent corrosion and fatigue resistance, and low elongation of ±2% at maximum dynamic working pressure.

PERFORMANCE:

Meets or Exceeds the Performance Requirements of: AS 3791 100R7, EN 855 TYPE R7, ISO 3949, SAE 100R7.

TUBE:

White, oil resistant seamless thermoplastic (Polyester).

REINFORCEMENT:

One or two braids of synthetic fibre.

COVER:

Orange, oil and abrasion resistant thermoplastic (Polyurethane). Cover is non-perforated.

FEATURES:

Meets non-conductivity requirements of SAE 100R7, AS 3791 100R7, EN 855 Type 7 (maximum leakage does not exceed 50 µA when subjected to 75 kV/305 mm or 250 kV/m for 5 minutes). Incorrect storage and use, particularly that leading to oil or moisture entering the reinforcement, may adversely affect electrical properties.

TEMPERATURE RANGE:

From -40°C to +100°C (-40°F to +212°F).
Air & Water +70 °C (+158 °F).
For water, emulsions etc. see page 58.

WORKING PRESSURE:

Maximum working pressures are based on 4:1 safety factor (maximum working pressure to minimum burst pressure).

COUPLINGS:

NON-SKIVE ONE-PIECE CRIMP

TP000 Series (sizes -04 to -16).
Assembly Instructions pages 146.

TP7TN - ISOLATOR		NOMINAL HOSE ID		NOMINAL HOSE OD		MAXIMUM WORKING PRESSURE		MINIMUM BURST PRESSURE		MINIMUM BEND RADIUS		AVERAGE WEIGHT		COUPLING SERIES ONE PIECE	
PART NO	HOSE SIZE	mm	inch	mm	inch	bar	psi	bar	psi	mm	inch	kg/m	lb/ft	NON-SKIVE	
TP74TN	6	-04	6,5	1/4	12,2	0.48	210	3000	840	12000	35	1.4	0,20	0.13	TP000
TP76TN	10	-06	9,7	3/8	16,0	0.63	160	2300	640	9200	55	2.2	0,30	0.20	TP000
TP78TN	12	-08	13,0	1/2	20,3	0.80	140	2000	560	8000	75	3.0	0,44	0.30	TP000

Refer to the latest Ryco Digital Crimp Tools for crimping parameters.

HOSES

THERMOPLASTIC

TP8 SPIDERLINE R8 HOSE



RECOMMENDED FOR:

High pressure hydraulic oil lines; pilot lines; greasing and lubrication lines; and some pneumatic and water lines. Suitable for use with mineral, vegetable and most ester based hydraulic fluids. Suitable for use with some gases, fluids and chemicals. Cover is perforated (pin-pricked) for use with air and gases.

Ryco SPIDERLINE hose is lighter weight, has a more compact outside diameter and is less than half the minimum bend radius of wire braided rubber hose. Smooth inner tube for high flow rate; and smooth, easily cleaned cover.

The synthetic and aramid fibre reinforcement gives SPIDERLINE hose excellent corrosion and fatigue resistance plus low elongation at maximum dynamic working pressure.

PERFORMANCE:

Meets or Exceeds the Performance Requirements of: AS 3791 100R8, EN 855 TYPE R8, ISO 3949, SAE 100R8.

TUBE:

White, oil resistant seamless thermoplastic (Polyester).

REINFORCEMENT:

One or two braids of aramid fibre.

COVER:

Black, oil and abrasion resistant thermoplastic (Polyurethane). Cover is perforated (pin-pricked).

TEMPERATURE RANGE:

From -40°C to +100°C (-40°F to +212°F).
For water, emulsions etc. see page 58.

WORKING PRESSURE:

Maximum working pressures are based on 4:1 safety factor (maximum working pressure to minimum burst pressure).

COUPLINGS:

NON-SKIVE ONE-PIECE CRIMP

TP000 Series (sizes -04 to -16).
Assembly Instructions pages 146.

TP8 - SPIDERLINE															
PART NO	HOSE SIZE	NOMINAL HOSE ID		NOMINAL HOSE OD		MAXIMUM WORKING PRESSURE		MINIMUM BURST PRESSURE		MINIMUM BEND RADIUS		AVERAGE WEIGHT		COUPLING SERIES ONE PIECE	
Hose	DN	Dash	mm	inch	mm	inch	bar	psi	bar	psi	mm	inch	kg/m	lb/ft	NON-SKIVE
TP84	6	-04	6,5	1/4	11,5	0.45	350	5000	1400	20000	50	2.0	0,09	0.06	TP000
TP86	10	-06	9,7	3/8	15,5	0.61	280	4000	1120	16000	60	2.4	0,14	0.09	TP000
TP88	12	-08	13,0	1/2	19,9	0.78	245	3500	980	14000	80	3.1	0,20	0.13	TP000

Refer to the latest Ryco Digital Crimp Tools for crimping parameters.

TP8N

**ISOLATOR
R8 NON CONDUCTIVE HOSE**



RECOMMENDED FOR:

Hydraulic oil lines where electrical non-conductivity is required (for use in applications where there is potential for contact with high voltage sources). Suitable for use with mineral, vegetable and most ester based hydraulic fluids. Heat and hydrolysis stabilised for use with water based hydraulic fluids up to +70°C (+158°F). Smooth inner tube for high flow rate; and smooth, easily cleaned cover. The high strength, non-metallic reinforcement gives these hoses excellent corrosion and fatigue resistance, and low elongation of ±2% at maximum dynamic working pressure.

PERFORMANCE:

Meets or Exceeds the Performance Requirements of: AS 3791 100R8, EN 855 TYPE R8, ISO 3949, SAE 100R8.

TUBE:

White, oil resistant seamless thermoplastic (Polyester).

REINFORCEMENT:

One or two braids of aramid fibre.

COVER:

Orange, oil and abrasion resistant thermoplastic (Polyurethane). Cover is non-perforated.

FEATURES:

Meets non-conductivity requirements of SAE 100R7, AS 3791 100R7, EN 855 Type 7 (maximum leakage does not exceed 50 µA when subjected to 75 kV/305 mm or 250 kV/m for 5 minutes). Incorrect storage and use, particularly that leading to oil or moisture entering the reinforcement, may adversely affect electrical properties.

TEMPERATURE RANGE:

From -40°C to +100°C (-40°F to +212°F).
Air & Water +70 °C (+158 °F).
For water, emulsions etc. see page 58.

WORKING PRESSURE:

Maximum working pressures are based on 4:1 safety factor (maximum working pressure to minimum burst pressure).

COUPLINGS:

NON-SKIVE ONE-PIECE CRIMP

TP000 Series (sizes -04 to -16).
Assembly Instructions pages 146.

TP8N - ISOLATOR		NOMINAL HOSE ID		NOMINAL HOSE OD		MAXIMUM WORKING PRESSURE		MINIMUM BURST PRESSURE		MINIMUM BEND RADIUS		AVERAGE WEIGHT		COUPLING SERIES ONE PIECE
PART NO	HOSE SIZE	mm	inch	mm	inch	bar	psi	bar	psi	mm	inch	kg/m	lb/ft	NON-SKIVE
TP84N	6 -04	6,5	1/4	11,5	0.45	350	5000	1400	20000	50	2.0	0,09	0.06	TP000
TP86N	10 -06	9,7	3/8	15,5	0.61	280	4000	1120	16000	60	2.4	0,14	0.09	TP000
TP88N	12 -08	13,0	1/2	19,9	0.78	245	3500	980	14000	80	3.1	0,20	0.13	TP000

Refer to the latest Ryco Digital Crimp Tools for crimping parameters.

HOSES

THERMOPLASTIC

TP8T SPIDERLINE R8 TWIN HOSE



RECOMMENDED FOR:

Ryco TP8T SPIDERLINE TWIN Hose consists of two TP8 Series Hoses of the same size, permanently joined together in a flat compact form that can be easily reeled onto payout and return reels on forklifts and cranes. It is also used on dispensing equipment and other applications requiring two hoses.

High pressure hydraulic oil lines; pilot lines; greasing and lubrication lines; and some pneumatic and water lines. Suitable for use with mineral, vegetable and most ester based hydraulic fluids. Suitable for use with some gases, fluids and chemicals. Cover is perforated (pin-pricked) for use with air and gases.

Ryco SPIDERLINE hose is lighter weight, has a more compact outside diameter and is less than half the minimum bend radius of wire braided rubber hose. Smooth inner tube for high flow rate; and smooth, easily cleaned cover.

The synthetic and aramid fibre reinforcement gives SPIDERLINE hose excellent corrosion and fatigue resistance plus low elongation at maximum dynamic working pressure.

PERFORMANCE:

Meets or Exceeds the Performance Requirements of: AS 3791 100R8, EN 855 TYPE R8, ISO 3949, SAE 100R8.

TUBE:

White, oil resistant seamless thermoplastic (Polyester).

REINFORCEMENT:

One or two braids of aramid fibre.

COVER:

Black, oil and abrasion resistant thermoplastic (Polyurethane). Cover is perforated (pin-pricked).

TEMPERATURE RANGE:

From -40°C to +100°C (-40°F to +212°F).

Air & Water +70 °C (+158 °F).

For water, emulsions etc. see page 58.

WORKING PRESSURE:

Maximum working pressures are based on 4:1 safety factor (maximum working pressure to minimum burst pressure).

COUPLINGS:

NON-SKIVE ONE-PIECE CRIMP

TP000 Series (sizes -04 to -16).

Assembly Instructions pages 146.

TP8T - SPIDERLINE															
PART NO	HOSE SIZE	NOMINAL HOSE ID		NOMINAL HOSE OD		MAXIMUM WORKING PRESSURE		MINIMUM BURST PRESSURE		MINIMUM BEND RADIUS		AVERAGE WEIGHT		COUPLING SERIES ONE PIECE	
Hose	DN	Dash	mm	inch	mm	inch	bar	psi	bar	psi	mm	inch	kg/m	lb/ft	NON-SKIVE
TP84T	6	-04	6,5	1/4	11,5	0.45	350	5000	1400	20000	50	2.0	0,17	0.11	TP000
TP86T	10	-06	9,7	3/8	15,5	0.61	280	4000	1120	16000	60	2.4	0,27	0.18	TP000
TP88T	12	-08	13,0	1/2	19,9	0.78	245	3500	980	14000	80	3.1	0,40	0.27	TP000

Refer to the latest Ryco Digital Crimp Tools for crimping parameters.



TP8TN

ISOLATOR
R8 NON CONDUCTIVE TWIN HOSE

RECOMMENDED FOR:

Ryco TP8TN ISOLATOR TWIN Hose consists of two TP8N Series Hoses of the same size, permanently joined together in a flat compact form that can be easily reeled onto payout and return reels on forklifts and cranes. It is also used for hydraulic powered hand tools, such as loppers and chain saws, and other applications requiring two hoses. TP8TN is used where electrical non-conductivity is required (for use in applications where there is potential for contact with high voltage sources). Suitable for use with mineral, vegetable and most ester based hydraulic fluids. Heat and hydrolysis stabilised for use with water based hydraulic fluids up to +70°C (+158°F). Suitable for use with some gases, fluids and chemicals (contact Ryco Hydraulics Technical Department). Smooth inner tube for high flow rate; and smooth, easily cleaned cover. The aramid reinforcement gives TP8TN Hose excellent corrosion and fatigue resistance, and low elongation of ±2% at maximum dynamic working pressure.

PERFORMANCE:

Meets or Exceeds the Performance Requirements of: AS 3791 100R8, EN 855 Type R8, ISO 3949, SAE 100R8.

TUBE:

White, oil resistant seamless thermoplastic (Polyester).

REINFORCEMENT:

One or two braids of aramid fibre.

COVER:

Orange, oil and abrasion resistant thermoplastic (Polyurethane). Cover is non-perforated.

FEATURES:

Meets non-conductivity requirements of SAE 100R7, AS 3791 100R7, EN 855 Type 7 (maximum leakage does not exceed 50 µA when subjected to 75 kV/305 mm or 250 kV/m for 5 minutes). Incorrect storage and use, particularly that leading to oil or moisture entering the reinforcement, may adversely affect electrical properties.

TEMPERATURE RANGE:

From -40°C to +100°C (-40°F to +212°F).

Air & Water +70 °C (+158 °F).

For water, emulsions etc. see page 58.

WORKING PRESSURE:

Maximum working pressures are based on 4:1 safety factor (maximum working pressure to minimum burst pressure).

COUPLINGS:

NON-SKIVE ONE-PIECE CRIMP

TP000 Series (sizes -04 to -16).

Assembly Instructions pages 146.

TP8TN - ISOLATOR															
PART NO	HOSE SIZE	NOMINAL HOSE ID		NOMINAL HOSE OD		MAXIMUM WORKING PRESSURE		MINIMUM BURST PRESSURE		MINIMUM BEND RADIUS		AVERAGE WEIGHT		COUPLING SERIES ONE PIECE	
Hose	DN	Dash	mm	inch	mm	inch	bar	psi	bar	psi	mm	inch	kg/m	lb/ft	NON-SKIVE
TP84TN	6	-04	6,5	1/4	11,5	0.45	350	5000	1400	20000	50	2.0	0,17	0.11	TP000
TP86TN	10	-06	9,7	3/8	15,5	0.61	280	4000	1120	16000	60	2.4	0,27	0.18	TP000
TP88TN	12	-08	13,0	1/2	19,9	0.78	245	3500	980	14000	80	3.1	0,40	0.27	TP000

Refer to the latest Ryco Digital Crimp Tools for crimping parameters.

HOSES

THERMOPLASTIC

TP3000

LOW TEMPERATURE R18
ISOBARIC HOSE
210 BAR / 3000 PSI



RECOMMENDED FOR:

Medium pressure hose suitable for petroleum or synthetic based hydraulic fluids in forklift systems. Optimum bonding characteristics and special cover also make it the ideal hose for equipment operating in cold environments, while maintaining a high level of flexibility.

PERFORMANCE:

Meets or Exceeds the Performance Requirements of: SAE 100 R18.

TUBE:

Polyester elastomer.

REINFORCEMENT:

One or two braids of synthetic fibre.

COVER:

Special polyester, black with white ink-jet branding. Cover is perforated (pin-pricked).

FEATURES:

Special polyester cover resistant to low temperatures and harsh weather conditions. Optimum bonding between tube, braids and cover for tight bend radii without cover wrinkling.

TEMPERATURE RANGE:

From -55°C to +100°C (-67°F to +212°F)

Air & Water +70 °C (+158 °F)

For water, emulsions etc. see page 58.

WORKING PRESSURE:

Maximum working pressures are based on 4:1 safety factor (maximum working pressure to minimum burst pressure).

COUPLINGS:

TP000 Series (sizes -04 to -16).

Assembly Instructions pages 146.

TP3000 - SPIDERLINE															
PART NO	HOSE SIZE	NOMINAL HOSE ID		NOMINAL HOSE OD		MAXIMUM WORKING PRESSURE		MINIMUM BURST PRESSURE		MINIMUM BEND RADIUS		AVERAGE WEIGHT		COUPLING SERIES ONE PIECE	
Hose	DN	Dash	mm	inch	mm	inch	bar	psi	bar	psi	mm	inch	kg/m	lb/ft	NON-SKIVE
TP3004	6	-04	6,5	1/4	12,2	0.48	210	3000	840	12000	35	1.4	0,09	0.06	TP000
TP3006	10	-06	9,7	3/8	16,6	0.65	210	3000	840	12000	45	1.8	0,16	0.11	TP000
TP3008	12	-08	13,0	1/2	22,5	0.89	210	3000	840	12000	70	2.8	0,29	0.20	TP000

Refer to the latest Ryco Digital Crimp Tools for crimping parameters.



TPGL
THERMOPLASTIC
HIGH PRESSURE
GREASELINE HOSE

RECOMMENDED FOR:

Thermoplastic constant pressure hose for high pressure greasing and lubrication systems.

TUBE:

White, oil resistant seamless thermoplastic polymer.

REINFORCEMENT:

One braid of synthetic fibre.

COVER:

Black, oil and abrasion resistant thermoplastic polymer. Cover is non-perforated.

FEATURES:

Polyester reinforcement for high pressure. Extremely compact and flexible, and highly kink resistant. Special low-friction smooth cover for easy installation and compact routing.

TEMPERATURE RANGE:

From -40°C to +100°C (-40°F to +212°F). For water, emulsions etc. see page 58.

WORKING PRESSURE:

Maximum working pressures are based on 4:1 safety factor (maximum working pressure to minimum burst pressure).

COUPLINGS:

NON-SKIVE ONE-PIECE CRIMP

TG000 Series (size -02).
Assembly Instructions pages 146.

FIELD ATTACHABLE NON-SKIVE

6000 Series insert (size -02).
P000 Series ferrule (size -02).

TPGL - GREASELINE		NOMINAL HOSE ID		NOMINAL HOSE OD		MAXIMUM WORKING PRESSURE		MINIMUM BURST PRESSURE		MINIMUM BEND RADIUS		AVERAGE WEIGHT		COUPLING SERIES		
PART NO	HOSE SIZE	mm	inch	mm	inch	bar	psi	bar	psi	mm	inch	kg/m	lb/ft	ONE PC	FIELD ATT	
TPGL2	4	-02	4,0	0.16	8,3	0.33	250	3600	1000	14400	25	0.98	0,05	0.03	TG000	6000 (P000)

Refer to the latest Ryco Digital Crimp Tools for crimping parameters.

HOSES

GREASING AND LUBRICATION

R4100N

FLEXIBLE GREASE GUN
EXTENSIONS

**RECOMMENDED FOR:**

Rubber-covered hose for high pressure greasing and lubrication systems.

TUBE:

Black, oil resistant seamless synthetic rubber.

REINFORCEMENT:

One braid of high tensile steel wire.

COVER:

Black, oil and abrasion resistant synthetic rubber.

FEATURES:

Suit standard grease guns.

High tensile wire reinforcement for high pressure and durability.

Available in a variety of lengths

TEMPERATURE RANGE:

From -40°C to +100°C (-40°F to +212°F).

For water, emulsions etc. see page 58.

WORKING PRESSURE:

Maximum working pressures are based on 4:1 safety factor (maximum working pressure to minimum burst pressure).

R4100 - FLEXIBLE GREASE GUN EXTENSIONS

PART NO	OVERALL LENGTH		END 1 CONNECTION	END 2 CONNECTION
	mm	inch		
Hose				
R4100	255	10	1/8" BSPT MALE	1/8" BSPT MALE
R4200	380	15	1/8" BSPT MALE	1/8" BSPT MALE
R4101	460	18	1/8" BSPT MALE	1/8" BSPT MALE
R4201	610	24	1/8" BSPT MALE	1/8" BSPT MALE
R4202	710	28	1/8" BSPT MALE	1/8" BSPT MALE



HOSE PROTECTION

EXTRA ABRASION RESISTANT

FRAS - FLAME RESISTANT ANTI STATIC



RYCO QUALITY

BUNDLE MULTIPLE HOSES

RCS CROCSLEEVE SHOWN ABOVE

HOSES

HOSE PROTECTION – FS1072 FIRE SLEEVE

FS1072 FIRE SLEEVE



MEETS OR EXCEEDS THE PERFORMANCE REQUIREMENTS OF:
SAE AEROSPACE STANDARD AS 1072.

RECOMMENDED FOR:

Increasing service life of hoses used in hostile environments. It is a tough, flexible insulation, which not only protects from intense external radiant heat, but also sheds molten metal splash. Consequently, damage to hoses is reduced and service life is increased. In the event of fire, hoses carrying flammable or hazardous materials remain intact longer. It can also be used to protect cables, pipes and wire ropes. Ryco FS1072 FIRE SLEEVE can also be used to reduce heat loss from hoses.

CONSTRUCTION:

Ryco FS1072 FIRE SLEEVE is manufactured from high bulk braided glass fibre tubing, coated with silicon rubber. The “danger red” colour of the silicon rubber is due to heavy loading of iron oxide to improve heat resistance.

TEMPERATURE RANGE:

Continuous exposure:

from -54°C to +260°C (-65°F to +500°F)

15 to 20 minutes:

from +260°C to +1090°C (+500°F to +2000°F)

15 to 30 seconds:

from +1090°C to +1640°C (+2000°F to +3000°F)

TYPICAL PROPERTIES:

K Value in $\frac{\text{BTU} \cdot \text{°F}}{\text{hr} \cdot \text{in}^2}$ 1.20

K Value in $\frac{\text{Cal}}{\text{cm} \cdot \text{sec} \cdot \text{cm}^2 \cdot \text{°C}}$ 0.0004134

FLAME RESISTANCE:

7 seconds to extinguish with no afterglow.

ABRASION RESISTANCE:

Wyzenbeck 9500 cycles, 3.1/3 lb pressure, 6 lb tension using fine emery cloth.

OIL AND FLUID RESISTANCE:

Remains functional after immersion for 120hr @ 80°F in MIL-H-5606, MIL-L-6082, Skydrol 500 LD and Skydrol 500.

SIZE SELECTION:

FS1072 FIRE SLEEVE performs best when installed with a loose fit over a hose. However, some end users insist on a tight fit for the sake of appearance. To achieve this tight fit, use compressed air to expand FIRE SLEEVE as it is installed over the hose. Length of FIRE SLEEVE will shorten in length as it increases in diameter, so allow for some extra length to compensate for this.

For a loose fit, there is no hard and fast rule to relate the Nominal Inside Diameter of FIRE SLEEVE with the Nominal Outside Diameter of the hose being covered. However, it is important to take two factors into account: hose length and hose cover.

For hoses up to 5 metres (16 ft) long, use a Nominal Inside Diameter of FIRE SLEEVE 15% larger than the Nominal Outside Diameter of hose being covered. For hoses over 5 metres (16 ft) long, use a size 20% larger. Remember the FIRE SLEEVE must slide over the outside of the hose. The longer the hose, the tougher it is to install, especially if enough tolerance on a long hose has not been allowed.

As the FIRE SLEEVE must slide over the outside of the hose, the hose covering also requires special consideration. A hose with a rough rubber cover is more difficult to slide FIRE SLEEVE over than a hose with a smooth cover.

For hose covers that have a high co-efficient of friction, be sure to allow for greater tolerance between the Nominal Inside Diameter of FIRE SLEEVE and the Nominal Outside Diameter of the hose to be covered.

Sizes FS1072-08 to FS1072-104:

Standard coil length is 15,24 metres (50 ft); or cut lengths. Lengths longer than 15,24 meters (50 ft) are also available, contact Ryco Customer Service.

Sizes FS1072-80 and FS1072-104:

Standard coil length is 5 metres (16.4 ft)

FS1072 FIRE SLEEVE can be slit longitudinally to form a flat FIRE TAPE which can be wound around larger diameter hoses and secured with stainless steel ties or FSTAPE-16.

FSTAPE-16

FSTAPE-16 is an iron oxide, red silicone rubber tape. It is designed to be, not only self-bonding and self-curing, but to also bond and cure onto FS1072 FIRE SLEEVE. It can be used to join separate sections of FIRE SLEEVE, as well as to repair any scuffed or nicked areas of FIRE SLEEVE. It can be used as an end sealant (instead of clamps) to prevent moisture and hydraulic oils wicking into the inner fibreglass braid.

FSTAPE-16 is supplied in a roll 25 mm WIDE x 11 metres LONG x 0,5 mm THICK (1 inch x 36 ft x 0.02 inch)



HOSE PROTECTION – FS1072 FIRE SLEEVE

FS1072 FIRE SLEEVE SPECIFICATIONS

PART NO	NOMINAL ID		NOMINAL WALL THICKNESS		NOMINAL INSIDE FLAT DIMENSION		NOMINAL WEIGHT	
	A mm	A inch	B mm	B inch	C mm	C inch	kg/m	lb/ft
FS1072-08	12,7	0.50	4,3	0.17	20,0	0.79	0,19	0.13
FS1072-11	17,5	0.69	4,3	0.17	27,5	1.08	0,29	0.19
FS1072-14	22,2	0.87	4,4	0.17	34,9	1.37	0,28	0.19
FS1072-16	25,4	1.00	4,8	0.19	39,9	1.57	0,31	0.21
FS1072-18	28,6	1.13	4,7	0.19	46,6	1.84	0,37	0.25
FS1072-20	31,8	1.25	4,7	0.19	47,4	1.87	0,36	0.24
FS1072-22	34,9	1.38	4,8	0.19	54,8	2.17	0,43	0.29
FS1072-24	38,1	1.50	4,0	0.16	58,3	2.29	0,46	0.31
FS1072-30	47,6	1.87	4,0	0.16	74,8	2.93	0,54	0.36
FS1072-32	50,8	2.00	4,0	0.16	79,8	3.14	0,55	0.37
FS1072-40	63,5	2.50	4,1	0.16	94,2	3.71	0,84	0.56
FS1072-44	69,9	2.75	5,0	0.20	109,8	4.32	0,85	0.57
FS1072-64	102,0	4.02	5,0	0.20	160,2	6.32	1,07	0.72
FS1072-80	127,0	5.00	5,0	0.20	199,5	7.89	2,26	1.52
FS1072-104	165,0	6.50	5,0	0.20	259,2	10.21	2,86	1.92

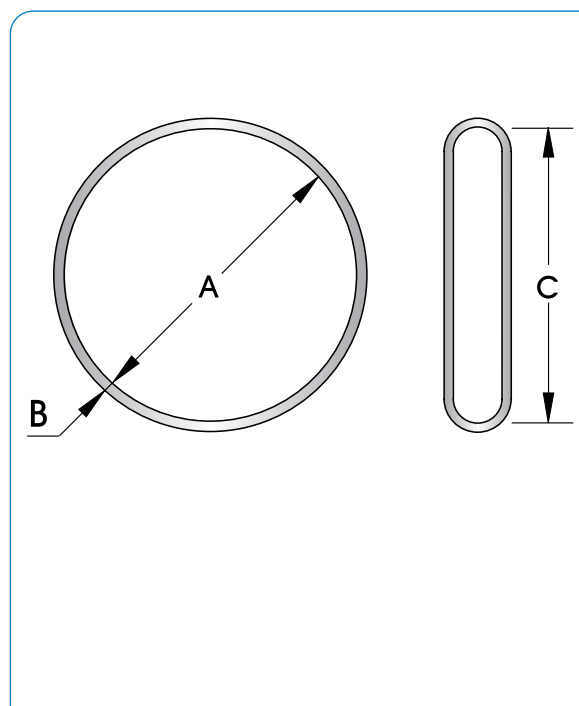

INTRODUCTION

HOSES

TECHNICAL

HOSE NOMINAL OUTSIDE DIAMETER REFERENCE CHART

This chart may be used as a quick reference to assist in choosing correct size of Hose Protection. Dimensions are nominal only, and are in millimetres. Divide by 25.4 to convert to inches.

HOSE SIZE			HOSE SERIES																								
DN	INCH	DASH	T3000D/S	T3600C	T3600D/S	T4000D/S	T5000D/S	T6000D/S	H3000D/S	H4000D/S	H5000C	H5000D/S	H6000D/S	C6000D/S	DF1D	DF2D	DK1D/E/S	DK2D/E/S	EC1	EC2	ECP1	E1	E2	T1D/S	T1F	T2D/S	
3	1/8	-02																									
5	3/16	-03																				10,3			11,7	11,7	
6	1/4	-04	11,8	11,8	11,8	11,8	13,2	13,2							12,2	13,4	11,6	12,7	12,2	13,4	11,8	13,0	14,6	13,3	13,3	14,9	
8	5/16	-05	14,4	14,4	14,4	15,6	15,6	15,6							13,9	14,9	13,4	14,8	13,9	14,9	13,3	14,6	16,4	14,9	14,9	16,5	
10	3/8	-06	15,6	15,6	15,6	16,6	17,1	17,6		19,3		19,3	19,3		15,6	17,3	15,0	16,4	15,6	17,3	14,9	16,7	18,5	17,3	17,3	18,9	
12	1/2	-08	18,7	19,9	19,9	20,6	20,6			22,7		22,7	22,7	21,4	19,0	20,3	18,3	19,7	19,0	20,3	18,3	20,0	21,7	20,3	20,3	21,9	
16	5/8	-10	23,4	23,4	23,4	23,4				24,9		26,2	26,2	28,5	20,2	23,6	21,5	22,8	20,2	23,6		23,4	24,9	23,6	23,6	25,1	
19	3/4	-12	27,6	27,6	27,6	28,4				30,0	29,6	29,6	30,6	35,5	25,6	27,6	24,7	26,1	25,6	27,6		27,4	28,9	27,6	27,6	29,1	
25	1	-16	34,8	35,	35,2					36,9	36,8	36,8	37,5		33,6	35,5	31,6	33,3	33,6	35,5		35,8	37,3	35,5	35,5	37,5	
31	1.1/4	-20								45,7	44,0	45,0	46,4			41,3	38,4	39,8							43,2		47,6
38	1.1/2	-24								50,3	50,8	52,7	53,1												50,2		54,1
51	2	-32								63,3	66,4	67,5	71,5												63,6		66,8
63	2.1/2	-40																									80,1
76	3	-48																									91,3

HOSES

HOSE PROTECTION - FS1072 FIRE SLEEVE

HOSE SIZE																							
DN	INCH	DASH	T2C	TX2AD	H12D/S	TJ2D	D4000D	SURVIVOR/1	SURVIVOR/2	SURVIVOR/R5	D2B	T5	MS1000	CS1000	BT1	SW	JS4000/G	JS4000BX/GX	JS6000/G	JS6000BX/GX	SRF/P	SRX/HT	RTH1
3	1/8	-02																					
5	3/16	-03																					
6	1/4	-04	15,0			14,9		13,4	15,0	13,2		13,2			13,3		11,5	12,6	12,4	13,5			9,4
8	5/16	-05	16,6			18,9		15,0	16,6	14,8		14,8			14,9		13,1	14,2	14,5	15,6			
10	3/8	-06	19,0		19,3			17,4	19,0	17,2		17,2			17,3	21,5	15,3	16,4	16,3	17,4			11,7
12	1/2	-08	22,2	22,0	22,7		22,7	20,5	22,0	19,4		19,4	18,5	18,5	20,3	24,6	18,3	19,4	19,3	20,4			15,4
16	5/8	-10	25,2	25,2	26,2			23,7	25,2	23,4		23,4	22,1	22,1	23,6								18,4
19	3/4	-12	29,1	29,1	30,0		30,0	27,6	29,1	27,4		27,4	25,8	25,8	27,6	31,9					31,5	29,6	22,1
25	1	-16	37,2	37,7	37,4		36,9	35,7	37,7	31,4		31,4	32,5	32,5	35,5	37,6					40,0	36,2	28,6
31	1.1/4	-20	47,4		45,7				48,0	38,1	40,4	38,1	39,5	39,5							46,5	44,0	
38	1.1/2	-24	53,8		53,0				54,4	44,5	48,0	44,5	46,0	46,0							53,1	49,4	
51	2	-32	66,7		66,0				67,3	56,3	62,0	56,3	59,1	59,1							65,5	63,8	
63	2.1/2	-40			82,6																		76,5
76	3	-48																					89,9

HOSE SIZE			HOSE SERIES							
DN	INCH	DASH	PL1D	MP1	TP7, TP7N	TP7T, TP7TN	TP8, TP8N	TP8T, TP8TN	TP3000	TPGL
3	1/8	-02								8,3
5	3/16	-03			9,6					
6	1/4	-04	12,7	13,5	12,2	12,2	11,5	11,5	12,2	
8	5/16	-05	14,3		14,3	14,3				
10	3/8	-06	15,9	17,5	16,0	16,0	15,5	15,5	16,6	
12	1/2	-08	19,8	21,4	20,3	20,3	19,9	19,9	22,5	
16	5/8	-10	23,0	25,4						
19	3/4	-12	26,4	28,6	27,1					
25	1	-16		37,3	34,0					
31	1.1/4	-20		43,9						
38	1.1/2	-24								
51	2	-32								
63	2.1/2	-40								
76	3	-48								



RCS
CROCSLEEVE
FLAME RESISTANT
ANTI-STATIC

RECOMMENDED FOR:

Hose burst and pinhole protection. Protection of individual hoses from severe abrasion. Provides a cost effective method of bundling hoses together, while providing abrasion resistance to the bundle. When abrasion occurs, the thousands of tiny filaments in the sleeve bulk up, to continually renew the surface.

CONSTRUCTION:

Densely woven, polyamide tubular sleeve. Black or Red colour. CROCSLEEVE is not affected by exposure to air, water, hydraulic oil and many other fluids. The inside bore of the CROCSLEEVE is smooth, allowing hose to move inside the sleeve, and allowing easy installation.

FRAS - FLAME RESISTANCE AND ANTI-STATIC:

Flame Resistant and Anti-Static - FRAS. Electrical conductivity is 3 to 5 MΩ/m when subjected to 500 Volts DC.

TEMPERATURE RANGE:

From - 50°C to + 121°C (- 58°F to + 250°F).

SIZE SELECTION:

Choose a size that is slightly larger than the hose or hoses to be sleeved - recommended size is 50% larger than nominal Hose OD (see chart on page 153). If CROCSLEEVE is to be installed onto fitted hose assemblies, allow for the maximum outside profile of the hose fittings.

ASSEMBLY INSTRUCTIONS:

1. Cut the CROCSLEEVE to length.
2. The loose fibres of the cut edges can be sealed with a heat gun or hot knife, to prevent fraying.
3. Install over hoses or hose assemblies.
4. Secure in place using adhesive-lined heat shrink tubing.

RCS CROCSLEEVE SPECIFICATIONS

PART NO		NOMINAL ID		NOMINAL FLAT ID		NOMINAL FLAT OD		NOMINAL WEIGHT	
Black	RED	A mm	A inch	B mm	B inch	C mm	C inch	kg/m	lb/ft
RCSB-20	RCSR-20	20	0.79	31	1.22	34	1.34	0,039	0.026
RCSB-23	RCSR-23	23	0.91	36	1.42	39	1.54	0,044	0.030
RCSB-27	RCSR-27	27	1.06	42	1.65	45	1.77	0,052	0.035
RCSB-31	RCSR-31	31	1.22	49	1.93	52	2.05	0,060	0.040
RCSB-36	RCSR-36	36	1.42	54	2.13	57	2.24	0,065	0.044
RCSB-44	RCSR-44	44	1.73	69	2.72	72	2.83	0,082	0.055
RCSB-47	RCSR-47	47	1.85	74	2.91	77	3.03	0,086	0.058
RCSB-55	RCSR-55	55	2.17	86	3.39	89	3.50	0,102	0.068
RCSB-60	RCSR-60	60	2.36	94	3.70	97	3.82	0,111	0.074
RCSB-66	RCSR-66	66	2.60	104	4.09	107	4.21	0,122	0.082
RCSB-73	RCSR-73	73	2.87	115	4.53	118	4.65	0,135	0.091
RCSB-93	RCSR-93	93	3.66	146	5.75	149	5.87	0,170	0.114
RCSB-112	RCSR-112	112	4.41	176	6.93	179	7.05	0,206	0.138
RCSB-129	RCSR-129	129	5.08	202	7.95	205	8.07	0,360	0.241

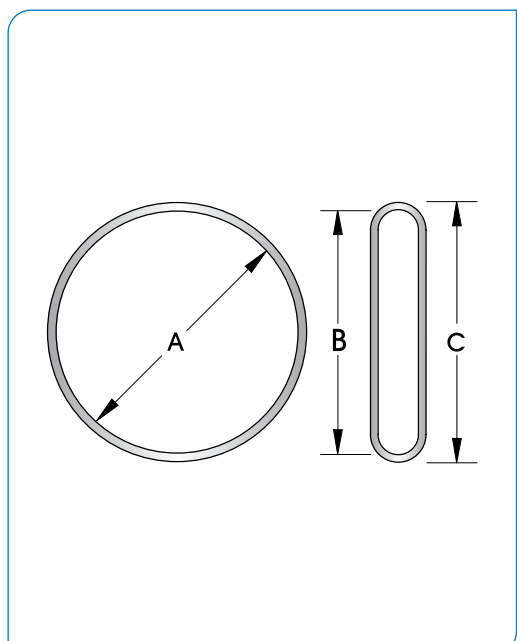

NOTE: In order to function as a burst diffuser, the RCS CROCSLEEVE size recommendations stated in this chart are approximately 50% larger than the corresponding Hose OD.



HOSES

HOSE PROTECTION – RCS CROCSLEEVE

CROCSLEEVE SIZE VERSUS HOSE AND DASH SIZE SELECTION TABLE

	T3000D/S	T3600D/S/C	T4000D/S	T5000D/S	T6000D/S	H3000D/S	H4000D/S	H5000D/S/C	H6000D/S	C6000D/S	DF1D	DF2D	DK1D/E/S	DK2D/E/S	EC1	EC2	ECP1	E1	E2
Part No.	Dash Size																		
RCSB-20	-04	-04	-04	-04	-04								-04	-04	-04	-04	-03,-04	-03,-04	
RCSB-23	-05	-05	-05	-05	-05						-04,-05	-04,-05	-05	-05	-05	-05	-05,-06	-05	-04
RCSB-27	-06	-06	-06	-06	-06						-06	-06	-06	-06	-06	-06	-08	-06	-05,-06
RCSB-31	-08	-08	-08	-08			-06	-06	-06	-08	-08,-10	-08	-10	-08	-08,-10	-08		-08	-08
RCSB-36	-10	-10	-10				-08	-08	-08		-12	-10	-12	-10		-10		-10	-10
RCSB-44	-12	-12	-12				-10	-10	-10	-12,-16	-16	-12	-16	-12	-12	-12		-12,-16	
RCSB-47							-12	-12	-12							-16			-12
RCSB-55	-16	-16					-16	-16	-16			-16		-16	-16				-16
RCSB-60												-20	-20	-20					
RCSB-66							-20	-20											
RCSB-73							-20		-20										
RCSB-93							-24	-24	-24	-24									
RCSB-112							-32	-32	-32	-32									
RCSB-129																			

NOTE: In order to function as a burst diffuser, the RCS CROCSLEEVE size recommendations stated in this chart are approximately 50% larger than the corresponding Hose OD.

CROCSLEEVE SIZE VERSUS HOSE AND DASH SIZE SELECTION TABLE

	T1D/S	T1F	T2D/S	TX2AD	H12D/S	TJ2D	D4000D	SURVIVOR/1	SURVIVOR/2	SURVIVOR/R5	D2B	T5	MS1000	CS1000	BT1	SW	JS4000/G
Part No.																	
RCSB-20	-03,-04	-03,-04						-04							-04		-04,-05
RCSB-23	-05	-05	-04			-04		-05	-04	-04,-05		-04,-05			-05		-06
RCSB-27	-06	-06	-05,-06			-06		-06	-05,-06	-06		-06	-08	-08	-06		
RCSB-31	-08	-08	-08		-06			-08	-08	-08		-08	-10	-10	-08	-06	-08
RCSB-36	-10	-10	-10	-08	-08		-08	-10	-10	-10		-10	-12	-12	-10	-08	
RCSB-44	-12	-12	-12	-10	-10			-12	-12	-12,-16		-12			-12		
RCSB-47				-12	-12		-12					-16	-16	-16	-16	-12	
RCSB-55	-16	-16	-16	-16			-16	-16	-16			-20				-16	
RCSB-60					-16						-20		-20	-20			
RCSB-66	-20	-20										-24					
RCSB-73	-24	-24	-20		-20				-20		-24		-24	-24			
RCSB-93	-32	-32	-24		-24				-24		-32	-32	-32	-32			
RCSB-112			-32		-32				-32								
RCSB-129			-40		-40												

NOTE: In order to function as a burst diffuser, the RCS CROCSLEEVE size recommendations stated in this chart are approximately 50% larger than the corresponding Hose OD.

CROCSLEEVE SIZE VERSUS HOSE AND DASH SIZE SELECTION TABLE

	JS4000BX/GX	JS6000/G	JS6000BX/GX	SRF/P	SRX/HT	RTH1	PL1D	MP1	TP7, TP7N	TP7T, TP7TN	TP8, TP8N	TP8T, TP8TN	TP3000	TPGL
Part No.														
RCSB-20	-04, -05	-04	-04			-04, -06	-04	-04	-03, -04		-04		-04	-02
RCSB-23	-06	-05	-05			-08	-05, -06	-06	-05, -06		-06		-06	
RCSB-27		-06	-06			-10								
RCSB-31	-08	-08	-08				-08	-08	-08		-08		-08	
RCSB-36						-12	-10	-10		-04				
RCSB-44				-12	-12	-16	-12	-12	-12			-04		
RCSB-47										-05				
RCSB-55								-16	-16	-06		-06		
RCSB-60				-16	-16							-08		
RCSB-66				-20	-20			-20		-08				
RCSB-73														
RCSB-93				-24	-24									
RCSB-112				-32	-32									
RCSB-129														

NOTE: In order to function as a burst diffuser, the RCS CROCSLEEVE size recommendations stated in this chart are approximately 50% larger than the corresponding Hose OD.

CROCSLEEVE - SAFETY FIRST

DESIGN FEATURES	BENEFITS
GREATER STRENGTH	CROCSLEEVE is made from high density PA (polyamide) for greater strength
FLAME RESISTANT - ABRASION RESISTANT	CROCSLEEVE is Flame Resistant and Anti-Static - FRAS
BURST RESISTANT	CROCSLEEVE is very resistant to hose burst
PIN HOLE RESISTANT	CROCSLEEVE is very resistant to hose pin holes
LEAK RESISTANT	CROCSLEEVE will allow pressure build up of up to 7 bar (100 psi)
STABLE	CROCSLEEVE is stable and has great resistance to sun, atmospheric agents and ageing
NON-TOXIC	CROCSLEEVE is non toxic
TOUGH	CROCSLEEVE is super tough
COLOURS	CROCSLEEVE comes in BLACK (RCSB) and RED (RCSR)
EASY INSTALLATION	CROCSLEEVE has a smooth bore providing easy installation of the hose

CHEMICALLY COMPATIBLE				
	Acetone	Very Good	Ether	Very Good
	Alcohols	Very Good	Gasoline	Very Good
	Bacterium	Very Good	Ionic Metallic Solutions	Very Good
	Benzene	Very Good	Mineral Oil	Very Good
	Carbon Tetrachloride	Very Good	Moths	Very Good
	Chlorine Based Solvents	Very Good	Mould	Very Good
	Diluted Acids	Good	Oil	Very Good
	Diluted Bases	Very Good	Vegetable Oil	Very Good

HOSES

HOSE PROTECTION – RAWHIDE NYLON HOSE SLEEVE

RH

RAWHIDE
NYLON HOSE SLEEVE



RECOMMENDED FOR:

Protection of individual hoses from severe abrasion. Provides a cost effective method of bundling hoses together, while providing abrasion resistance to the bundle. When abrasion occurs, the thousands of tiny filaments in the sleeve bulk up, to continually renew the surface.

CONSTRUCTION:

Densely woven, multi-filament nylon, tubular sleeve. Black colour. Nylon is not affected by exposure to air, water, hydraulic oil and many other fluids. The inside bore of the sleeve is smooth, allowing hose to move inside the sleeve, and allowing easy installation.

FLAME RESISTANCE:

Meets Flame Resistant Designation "U.S. MSHA" of the U.S. Department of Labor, Mine Safety and Health Administration.

TEMPERATURE RANGE:

From - 50°C to + 121°C (- 58°F to + 250°F).

SIZE SELECTION:

Choose a size that is slightly larger than the hose or hoses to be sleeved (see chart on page 156). If sleeve is to be installed onto fitted hose assemblies, allow for the maximum outside profile of the hose fittings.

ASSEMBLY INSTRUCTIONS:

1. Cut the Nylon Hose Sleeve to length.
2. The loose fibres of the cut edges can be sealed with a heat gun or hot knife, to prevent fraying.
3. Install over hoses or hose assemblies.
4. Secure in place using cable ties, band clamps or hose clamps.

STANDARD COIL LENGTHS:

91,4 metre (300 ft) long coils; or cut lengths.



RH RAWHIDE SPECIFICATIONS

RAWHIDE NYLON HOSE SLEEVE

PART NO	NOMINAL ID		NOMINAL WALL THICKNESS		NOMINAL INSIDE FLAT DIMENSION		NOMINAL WEIGHT	
	A mm	A inch	B mm	B inch	C mm	C inch	kg/m	lb/ft
RH-23	22,9	0.90	2,3	0.09	29,8	1.41	0,06	0.03
RH-27	26,9	1.06	2,3	0.09	39,8	1.67	0,07	0.04
RH-31	31,0	1.22	2,3	0.09	49,9	1.92	0,08	0.05
RH-36	36,0	1.42	2,5	0.10	56,6	2.23	0,09	0.06
RH-46	46,0	1.81	2,5	0.10	72,1	2.84	0,12	0.08
RH-56	55,6	2.19	2,5	0.10	87,4	3.44	0,15	0.10
RH-61	60,5	2.38	2,5	0.10	95,0	3.74	0,16	0.11
RH-67	66,8	2.63	2,5	0.10	104,6	4.12	0,17	0.12
RH-73	73,2	2.88	2,5	0.10	115,1	4.53	0,19	0.13
RH-93	93,0	3.66	2,5	0.10	146,1	5.75	0,25	0.17

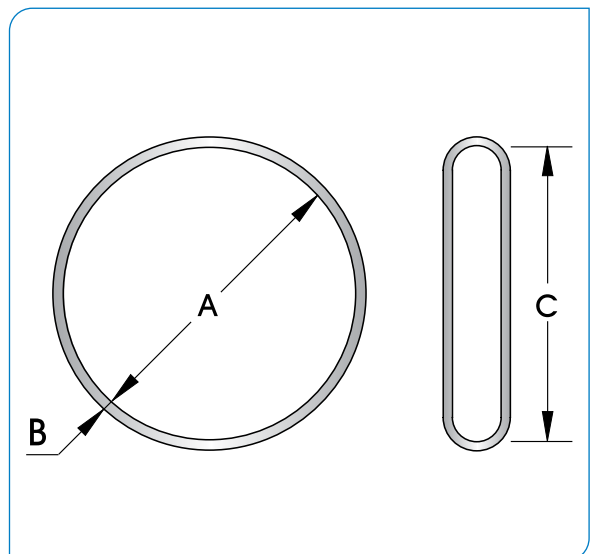

NOTE: In order to function as a burst diffuser, the RCS CROCSLEEVE size recommendations stated in this chart are approximately 50% larger than the corresponding Hose OD.

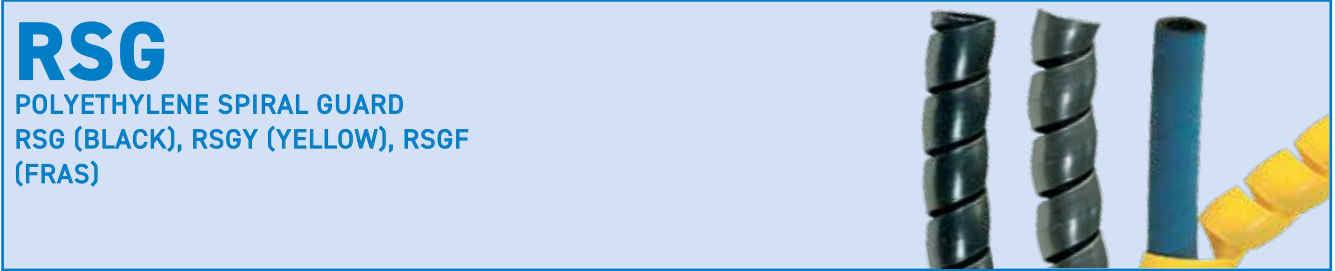

RSG

POLYETHYLENE SPIRAL GUARD
RSG (BLACK), RSGY (YELLOW), RSGF
(FRAS)

RECOMMENDED FOR:

Lightweight, cost-effective protection of hoses and cables from abrasion and impact. It can also be used to bundle hoses together in groups. RSGF meets Flame Resistance Designation "U.S. MSHA" of the US Department of Labor, Mine Safety and Health Administration.

CONSTRUCTION:

Polyethylene plastic spiral, with rounded edges to protect hose cover. RSG Black; RSGY Yellow; RSGF FRAS (Dark Grey). Polyethylene is not affected by exposure to air, water, hydraulic oil and many other fluids.

TEMPERATURE RANGE:

From -40°C to +120°C (-40°F to +248°F).

ASSEMBLY INSTRUCTIONS:

Ryco Spiral Guard can easily be applied after hose assembly because of its spiral form. Place one end of completed hose assembly in a vice. Wrap coil onto hose. It is recommended to choose Ryco Spiral Guard size so that it is a tight fit on the hose.

This will keep the Spiral Guard in place on the hose. The Spiral Guard expands to fit the hose or hose bundle. Allow extra length of Spiral Guard to allow for this expansion.

SIZE SELECTION:

The tables below show Ryco Spiral Guard size selection for a tight fit on the hose. Due to the Spiral Guard expanding to fit the hose, extra length of Spiral Guard must be allowed. This extra length can be estimated as follows:

T26A Nominal OD = 18,9 mm (see chart on page 153)
 RSG-20L Nominal ID = 15,0 mm (from chart below)
 Estimated length of RSG-20L to cover 2,3 metres of T26A

$$= \frac{18,9}{15,0} \times 2,3 \text{ m} = 2,90 \text{ metres}$$

HOW TO ORDER:

Complete the Part Number: **RSG-16L, RSGY-75L, RSGF-50L** etc.

Sizes -16L to -90L: 20 m (65.6 ft) coils or cut to length.

Size -110L: 10 m (32.8 ft) coils or cut to length.

SPIRAL GUARD					HOSE SERIES																			
DASH SIZE	NOMINAL ID		NOMINAL OD		T3000D/S	T3600C	T3600D/S	T4000D/S	T5000D/S	T6000D/S	H3000D/S	H4000D/S	H5000C	H5000D/S	H6000D/S	C6000D/S	DF1D	DF2D	DK1D/E/S	DK2D/E/S	EC1	EC2	ECP1	E1
	MM	INCH	MM	INCH																				
-12L	9,0	0.35	13,0	0.51	-4	-4	-4	-4	-4								-4		-4	-4	-4		-3,-4	
-16L	12,0	0.47	16,5	0.65	-5,-6	-5,-6	-5,-6	-5	-5	-4,-5							-5,-6	-4,-5	-5,-6	-5	-5	-4,-5	-5,-6	-4,-5
-20L	15,0	0.59	20,0	0.79	-8		-8	-6	-6	-6	-6		-6	-6	-6		-8	-6	-8	-6	-6,-8	-6	-8	-6
-25L	19,0	0.75	24,5	0.96	-10	-8,-10	-10	-8,-10	-8	-8		-8		-8	-8	-8	-10	-8,-10	-10	-8,-10	-10	-8		-8,-10
-32L	23,0	0.91	30,0	1.18	-12	-12	-12	-12				-10,-12	-12	-10,-12	-10,-12	-12	-12	-12	-12	-12	-12	-10,-12		-12
-40L	30,5	1.20	39,0	1.54	-16	-16	-16					-16	-16	-16	-16	-16	-16	-16	-16	-16	-16	-16		-16
-50L	38,0	1.50	46,5	1.83							-20	-20	-20	-20	-20			-20		-20				
-63L	47,0	1.85	58,0	2.28							-24	-24		-24	-24									
-75L	61,0	2.40	73,0	2.87							-32	-32		-32										
-90L	70,5	2.78	84,5	3.33											-32									
-110L	84,0	3.31	99,0	3.90																				

HOSES

HOSE PROTECTION - RSG/RSGY/SGF SPIRAL

RSG

POLYETHYLENE SPIRAL GUARD
RSG (BLACK), RSGY (YELLOW), RSGF (FRAS)

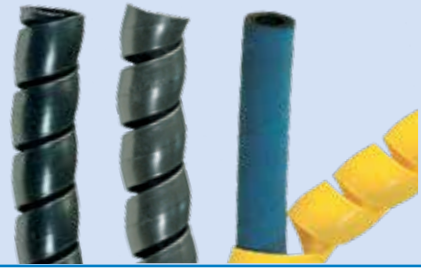

SPIRAL GUARD					HOSE SERIES (CONT)													
--------------	--	--	--	--	--------------------	--	--	--	--	--	--	--	--	--	--	--	--	--

DASH SIZE	NOMINAL ID		NOMINAL OD		E2	T1D/S	T1F	T2D/S	T2C	TXA2D	H12D/S	TJ2D	D4000D	SURVIVOR/1	SURVIVOR/2	SURVIVOR/R5	D2B	T5	MS1000
	MM	INCH	MM	INCH															
-12L	9,0	0.35	13,0	0.51		-3	-3							-4		-4		-4	
-16L	12,0	0.47	16,5	0.65	-4	-4,-5	-4,-5	-4	-4			-4		-5	-4	-5		-5	
-20L	15,0	0.59	20,0	0.79	-5,-6	-6	-6	-5,-6	-5,-6		-6	-6		-6	-5,-6	-6,-8		-6,-8	-8
-25L	19,0	0.75	24,5	0.96	-8	-8,-10	-8,-10	-8	-8	-8	-8		-8	-8,-10	-8	-10		-10	-10
-32L	23,0	0.91	30,0	1.18	-10,-12	-12	-12	-10,-12	-10,-12	-10,-12	-10		-12	-12	-10,-12	-12		-12	-12
-40L	30,5	1.20	39,0	1.54	-16	-16	-16	-16	-16	-16	-12,16		-16	-16	-16	-16,-20		-16,-20	-16
-50L	38,0	1.50	46,5	1.83		-20			-20		-20				-20	-24	-20	-24	-20,-24
-63L	47,0	1.85	58,0	2.28		-24		-20,-24	-20,-24		-24				-24	-32	-24	-32	-32
-75L	61,0	2.40	73,0	2.87		-32		-32	-32		-32				-32		-32		
-90L	70,5	2.78	84,5	3.33				-40			-40								
-110L	84,0	3.31	99,0	3.90				-48											

DASH SIZE	NOMINAL ID		NOMINAL OD		CS1000	BT1	SW	JS4000/G	JS4000/GX/BX	JS6000/G	JS6000/GX/BX	SRF/P	SRX/HT	RTH1	PL1D	MP1	TP7/N,T/TN TP7N	TP8T, TP8TN	TP3000	TP6L
	MM	INCH	MM	INCH																
-12L	9,0	0.35	13,0	0.51				-4	-4	-4				-4,-6	-4		-4	-4	-4	-2
-16L	12,0	0.47	16,5	0.65		-4,-5		-5,-6	-5	-5	-4,-5			-8	-5		-5,-6	-6	-6	
-20L	15,0	0.59	20,0	0.79	-8	-6,		-8	-6,-8	-6,-8	-6			-10	-6,-8	-4,-6	-8	-8		
-25L	19,0	0.75	24,5	0.96	-10	-8,-10	-6				-8			-12	-10	-8,-10			-8	
-32L	23,0	0.91	30,0	1.18	-12	-12	-8						-12	-16	-12	-12	-12			
-40L	30,5	1.20	39,0	1.54	-16	-16	-12,-16						-12	-16		-16	-16			
-50L	38,0	1.50	46,5	1.83	-20,-24							-16,-20	-20			-20				
-63L	47,0	1.85	58,0	2.28	-32							-24	-24							
-75L	61,0	2.40	73,0	2.87								-32	-32							
-90L	70,5	2.78	84,5	3.33									-40							
-110L	84,0	3.31	99,0	3.90									-48							

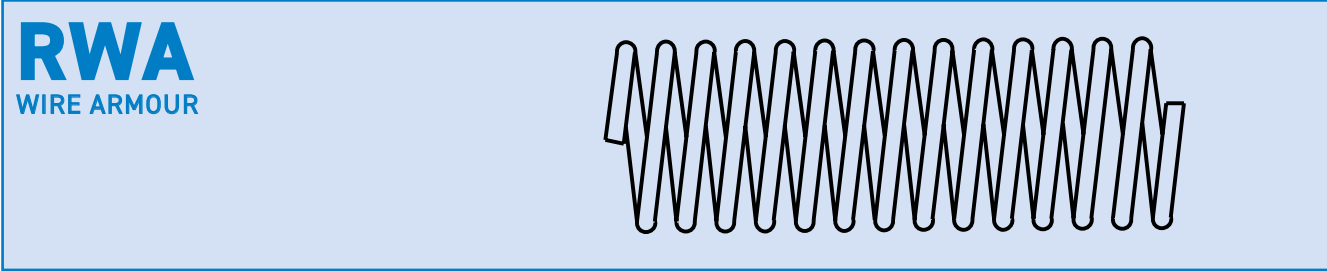

RECOMMENDED FOR:

Protection for Hose Cover in arduous operating conditions; especially against abrasion and deep gouges, thus prolonging the life of the Hose.

CONSTRUCTION:

Spring Steel Wire; galvanised for corrosion protection.

TEMPERATURE RANGE:

Suitable for use with all Ryco Hoses at their published temperature ranges.

ASSEMBLY INSTRUCTIONS:

1. Slide RWA Wire Armour over hose after first end of hose assembly is completed.
2. Then complete second end of hose assembly.

STANDARD LENGTH:

6 metres (19.7 ft) in all sizes.

WIRE ARMOUR		HOSE SERIES																						
PART NO	NOMINAL ID		T3000D/S	T3600C	T3600D/S	T4000D/S	T5000D/S	T6000D/S	H3000D/S	H4000D/S	H5000C	H5000D/S	H6000D/S	C6000D/S	DF1D	DF2D	DK1D/E/S	DK2D/E/S	EC1	EC2	ECP1	E1	E2	
	MM	INCH																						
RWA-12	12	0.47																						
RWA-16	16	0.63	-4,-5	-4,-5	-4,-5	-4	-4	-4							-4,-5	-4,-5	-5,-6	-4,-5	-4,-5	-4,-5			-4,-5	-4
RWA-20	20	0.78	-6	-6	-6	-5,-6	-5,-6	-5,-6							-6,-8	-6	-8	-6	-6	-6			-6	-5,-6
RWA-21	21	0.83	-8	-8	-8					-6		-6	-6		-10	-8		-8	-8,-10	-8			-8	
RWA-23	23	0.91				-8	-8	8						-8			-10	-10						-8
RWA-27	27	1.06	-10	-10	-10	-10	-10			-8,-10		-8	-8		-12	-10	-12	-12	-12	-10			-10	-10
RWA-30	30	1.19	-12	-12	-12	-12	-12					-10	-10	-12		-12				-12			-12	
RWA-31	31	1.22									-12	-12												-12
RWA-34	34	1.34								-12			-12				-16	-16						
RWA-39	39	1.52	-16	-16	-16					-16	-16	-16	-16	-16	-16	-16	-20			-16	-16		-16	-16
RWA-41	41	1.61																-20						
RWA-49	49	1.93								-20	-20	-20	-20	-20		-20								
RWA-56	56	2.2								-24	-24		-24	-24										
RWA-61	61	2.4																						
RWA-68	68	2.68								-32	-32													
RWA-75	75	2.95										-32	-32											

HOSES

HOSE PROTECTION – RWA WIRE ARMOUR

RWA
WIRE ARMOUR

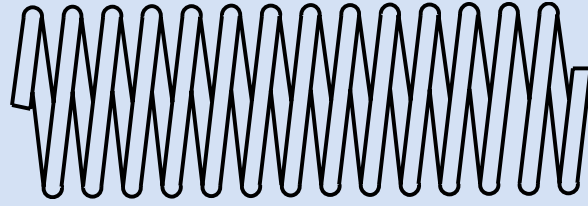

WIRE ARMOUR																					
PART NO	NOMINAL ID		T1D/S	T1F	T2D/S	T2C	TXA2D	H12D/S	TJ2D	D4000D	SURVIVOR/1	SURVIVOR/2	SURVIVOR/R5	D2B	T5	MS1000	CS1000	BT1	SW	JS4000/GX/BX	
	MM	INCH																			
RWA-12	12	0.47																			
RWA-16	16	0.63	-4,-5		-4	-4					-4,-5	-4	-4,-5		-4,-5				-4,-5		-4,-5
RWA-20	20	0.78	-6		-5	-5			-4		-6	-5	-6		-6				-6		-6
RWA-21	21	0.83			-6	-6			-6			-6	-8		-8	-8	-8				-8
RWA-23	23	0.91	-8		-8	-8	-8	-6			-8	-8							-8	-6	
RWA-27	27	1.06	-10		-10	-10	-10	-8		-8	-10	-10	-10		-10	-10,-12	-10,-12		-10	-8	
RWA-30	30	1.19	-12					-10			-12		-12		-12				-12		
RWA-31	31	1.22			-12	-12	-12					-12									
RWA-34	34	1.34						-12		-12			-16		-16	-16	-16			-12	
RWA-39	39	1.52	-16		-16	-16				-16									-16	-16	
RWA-41	41	1.61					-16	-16				-16	-20	-20	-20	-20	-20				
RWA-49	49	1.93	-20		-20	-20	-20	-20				-20	-24		-24	-24	-24				
RWA-56	56	2.2	-24		-24	-24		-24				-24		-24							
RWA-61	61	2.4											-32		-32	-32	-32				
RWA-68	68	2.68	-32		-32	-32		-32				-32		-32							
RWA-75	75	2.95																			

PART NO	NOMINAL ID		JS4000/GX/BX	JS6000/G	JS6000/GX/BX	SRE/P	SRX/HT	RTH1	PL ID	MP1	TP7, TP7N	TP7T, TP7TN	TP8, TP8N	TP8T, TP8TN	TP3000
	MM	INCH													
RWA-12	12	0.47						-4			-3				
RWA-16	16	0.63	-4,-5	-4,-5	-4			-6,-8	-4,-5	-4	-4,-5		-4		-4
RWA-20	20	0.78	-6	-6	-5,-6				-6	-6	-6		-6		-6
RWA-21	21	0.83	-8	-8	-8			-10	-8				-8		
RWA-23	23	0.91								-8	-8				-8
RWA-27	27	1.06						-12	-10	-10		-4		-4	
RWA-30	30	1.19						-12	-12	-12	-12	-5			
RWA-31	31	1.22						-16							
RWA-34	34	1.34										-6		-6	
RWA-39	39	1.52				-12	-16				-16				
RWA-41	41	1.61				-16						-8		-8	
RWA-49	49	1.93				-20	-20								
RWA-56	56	2.2				-24	-24								
RWA-61	61	2.4													
RWA-68	68	2.68				-32	-32								
RWA-75	75	2.95													

RHYS PACKAGING SLEEVE



INTRODUCTION

HOSES

TECHNICAL

RECOMMENDED FOR:

Packaging and protection of hose assemblies, in transit and in storage. Ryco RHYS Packaging Sleeve is installed over the finished hose assembly. The ends may be heat sealed, or folded over and stapled, or taped closed.

CONSTRUCTION:

Heavy gauge low density polyethylene clear plastic tubing; printed at intervals with "Ryco" logo, and incorporating an area for the hose assembly Part Number to be written.

ASSEMBLY INSTRUCTIONS:

1. Select correct size of Ryco RHYS Packaging Sleeve. It must be large enough to allow for the maximum outside profile of the hose couplings.
2. Two sizes are available:
3. RHYS-75 suits most hoses up to -16 (1") hose bore.
4. RHYS-125 suits most hoses from -16 to -32 (1" to 2") hose.
5. If required, write the hose assembly Part Number onto the Packaging Sleeve using a ball point pen.
6. Slide the hose assembly into the RHYS Packaging Sleeve.
7. Trim Packaging Sleeve to length, and seal ends.

STANDARD COIL LENGTHS:

350 metres (1,150 feet).

RHYS HOSE ASSEMBLY PACKAGING SLEEVE SPECIFICATIONS

PART NO	PACKAGING SLEEVE							
	NOMINAL ID		NOMINAL WALL THICKNESS		NOMINAL INSIDE FLAT DIMENSION		NOMINAL WEIGHT	
	A mm	A inch	B mm	B inch	C mm	C inch	kg/m	lb/ft
RHYS-75	48	1.9	0,15	0.006	75	3.0	0,021	0.014
RHYS-125	79	3.1	0,15	0.006	125	5.0	0,035	0.023

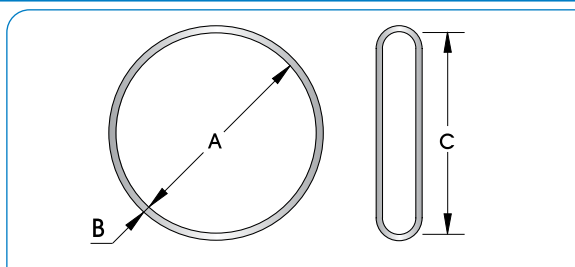

HOSES

HOSE PROTECTION – 750/760 SPRING GUARD

750/760 SPRING GUARD

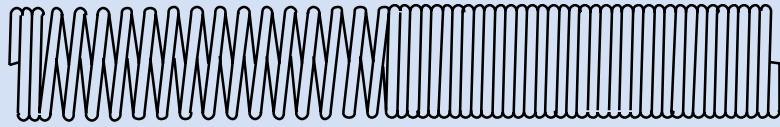

RECOMMENDED FOR:

TJ24D and TJ26D Specialist Jacking Hose Assemblies, to control bend radius at end of hoses to avoid excessive strain on hose couplings. Can also be used with E24, E26, SURVIVOR/24, SURVIVOR/26, T24C, T24D, T24S, T26C, T26D and T26S Hoses. Can be used with L000 Series Field Attachable and T2000 Series BITELOK Couplings.

- 750** Suits some -4 (1/4") and -6 (3/8") hoses
- 760** Suits some -6 (3/8") hoses

CONSTRUCTION:

Spring Steel Wire; galvanised for corrosion protection.

ASSEMBLY INSTRUCTIONS:

Slide Spring Guards over the hose before assembling hose ends. After ends are assembled, twist and push Spring Guards onto the ferrules. The close pitched end of the Spring Guard goes over the ferrule, and the wide pitched end goes over the hose (as depicted in below image).

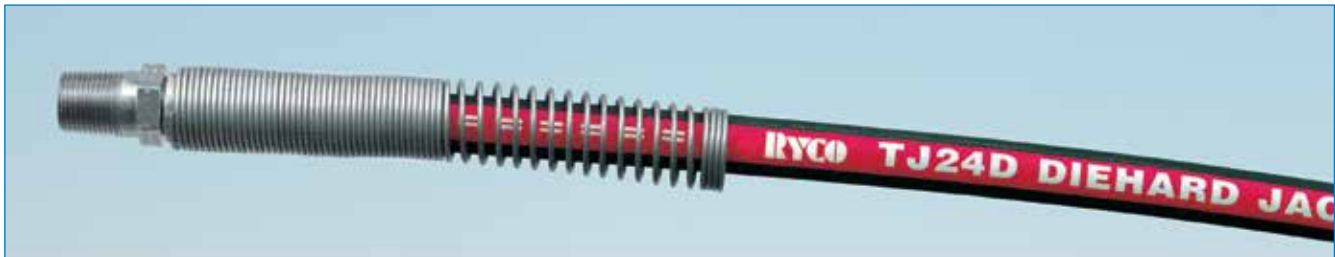



RHYT/RHWT HOSE TAG

RECOMMENDED FOR:

Permanent identification of hose assemblies. Ryco Hose Tags enable hose assembly information to be attached to the hose assembly in a cost effective manner.

Two sizes of Hose Tags allow all common hose sizes to be tagged.

Information can be written or printed on the Hose Tag prior to being attached to the hose. When the Hose Tag is wrapped on the hose, a clear panel at the end of the tag wraps over to protect the written or printed information.

Hose Tag remains in position on the hose due to the adhesive backing, and the Hose Tag bends with the hose, ensuring that flexibility is not affected.

The slim profile of the attached Hose Tag reduces the risk of accidental removal. Hose Tag does not damage or cut the cover of the hose.

CONSTRUCTION:

Heat, oil, ozone, sunlight, and weather resistant high performance plastic.

Adhesive-backed for permanent attachment to the hose assembly. Area to write or print information, with a clear panel that wraps over to protect the hose assembly identification information.

TEMPERATURE RANGE:

Suitable for use with all Ryco Hoses at their published temperature ranges.

ASSEMBLY INSTRUCTIONS:

1. Select correct size of Ryco RHYT Hose Tag for the hose assembly that is to be identified.
2. Two sizes are available:
3. **RHYT-10** and **RHWT-10** suits hose sizes -04 to -10 (1/4" to 5/8").
4. **RHYT-32** and **RHWT-32** suits hose sizes -12 to -32 (3/4" to 2").
5. Using a ball point pen or label printer, apply the required information onto the Hose Tag.
6. Remove the release paper from the back of the Hose Tag to expose the adhesive.
7. While ensuring that the Hose Tag is parallel to the axis of the hose, wrap the Hose Tag tightly around the hose, then continue to wrap the clear plastic panel over the Hose Tag.
8. Press firmly to ensure that the adhesive bonds.

RHYT HOSE TAGS SPECIFICATIONS

RHYT/RHWT HOSE TAGS			
PART NO	SUITS HOSE SIZE ID RANGE		
	DN	INCH	DASH
RHYT-10	6 to 16	1/4 to 5/8	-04 to -10
RHYT-32	12 to 51	3/4 to 2	-12 to -32
RHWT-10	6 to 16	1/4 to 5/8	-04 to -10
RHWT-32	12 to 51	3/4 to 2	-12 to -32

Contact Ryco for further information.

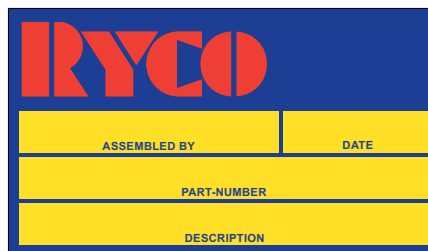

RHYT-32

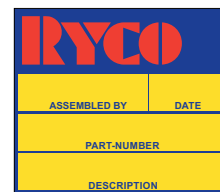

RHYT-10

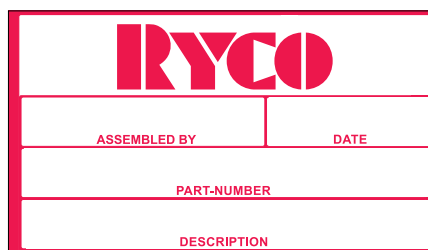

RHWT-32



RHWT-10

HOSES

HOW TO ORDER RYCO HYDRAULIC HOSE

SEE PAGES 467 AND 468 FOR "HOW TO ORDER HOSE ASSEMBLIES".

Coil length of Ryco Hydraulic Hose varies according to Hose Series and Size.

Wire braid, textile braid and spiral wire reinforced hydraulic hoses are in most cases manufactured in long lengths on flexible mandrels, which results in coils of hose of different lengths. These hoses are produced and supplied in random lengths.

SRF/P and SRX/HT Suction Hoses are manufactured on rigid mandrels of a specified length.

SRF/P and SRX/HT Hose 20 metres (65.6 ft)

If hose is part of a general stock order, every effort will be made to supply length closest to length ordered, but length supplied may be shorter or longer than length ordered. If ordering "a coil" of hose, please specify the length required. If a specific cut length is required, this must be specified when ordering, e.g. 19.5 metres exact length and may be subject to surcharge.

Shown in the table below is the availability of Ryco Hydraulic Hose in Coils (C), and on Reels (R) or in Bulk Cartons (B).

Details of average quantities packed on reels (or in cartons) and their dimensions are available from Ryco on request.

HOSE SERIES

HOSE SIZE		T3000D/S	T3600C	T4000D/S	T5000D/S	T6000D/S	H3000D/S	H4000D/S	H5000C	H5000D/S	H6000D/S	C6000D	C6000S	DF1D	DF2D	DK1D/E/S	DK2D/E/S	EC1/2	ECP1	E1	E2	T1D/S	T1F	T2D/S	T2C	TXA2D	H12D/S	TJ2D	D4000D	SURVIVOR/1	SURVIVOR/2	SURVIVOR/R5	
-03	3/16"																					R	R,C										
-04	1/4"	R,C	R,C	R,C	R,C	R,C								R,C	R,C	R,C	R,C	R,C		R,C	R,C	R,C	R,C	R,C	R,C			R,C		R,C	R,C	R,C	R,C
-05	5/16"	R,C	R,C	R,C	R,C	R,C								R,C	R,C	R,C	R,C	R,C		R,C	R,C	R,C	R,C	R,C	R,C			R,C		R,C	R,C	R,C	R,C
-06	3/8"	R,C	R,C	R,C	R,C	R,C		R,C		R,C	R,C			R,C	R,C	R,C	R,C	R,C		R,C	R,C	R,C	R,C	R,C	R,C		R,C		R,C	R,C	R,C	R,C	R,C
-08	1/2"	R,C	R,C	R,C	R,C			R,C		R,C	R,C	R,C	R,C	R,C	R,C	R,C	R,C	R,C		R,C	R,C	R,C	R,C	R,C	R,C	R,C		R,C		R,C	R,C	R,C	R,C
-10	5/8"	R,C	R,C	R,C				R,C,B		R,C,B	R,C			R,C	R,C	R,C	R,C	R,C		R,C	R,C	R,C	R,C	R,C	R,C	R,C			R,C	R,C	R,C	R,C	R,C
-12	3/4"	R,C	R,C	R,C				R,C,B	R,C	R,C,B	R,C	R,C	R,C	R,C	R,C	R,C	R,C	R,C		R,C	R,C	R,C	R,C	R,C	R,C	R,C			R,C,B	R,C	R,C	R,C	R,C
-16	1"	R,C	R,C					R,C,B	R,C	R,C,B	R,C	R,C	R,C	R,C	R,C	R,C	R,C	R,C		R,C	R,C	R,C	R,C	R,C	R,C	R,C			R,C,B	R,C	R,C	R,C	R,C
-20	1.1/4"						B	B	B	B	B					B	B	B				B		B	B		B				B	B	
-24	1.1/2"						B	B		B	B											B		B	B		B				B	B	
-32	2"						B	B		B	B											B		B	B		B				B	B	
-40	2.1/2"																							B			B						
-48	3"																							B									

HOSE SIZE		D2B	T5	MS1000	CS1000	BT1	SW	JS4000/G/GX/BX	JS6000/G/GX/BX	SRF/P	SRX/HT	RTH1	PL1D	MP1	TP7	TP7N	TP7T/TN	TP8	TP8N	TP8T	TP8TN	TP3000	
-03	3/16"												R,C		R,B								
-04	1/4"		R,C			R,C			R,C			R,C	R,C	R,C	R,C	R,C	R,C	R,C	R,C	R,C	R,C	R,C	R,C
-05	5/16"		R,C			R,C		R,C	R,C			R,C	R,C		R,C		R,C						
-06	3/8"		R,C			R,C	R,C	R,C,B	R,C			R,C	R,C	R,C	R,C	R,C	R,C	R,C	R,C	R,C	R,C	R,C	R,C
-08	1/2"		R,C	R,C	R,C	R,C	R,C	R,C	R,C			R,C	R,C	R,C	R,C	R,C	R,C	R,C	R,C	R,C	R,C	R,C	R,C
-10	5/8"		R,C	R,C	R,C	R,C		R,C				R,C	R,C	R,C									
-12	3/4"		R,C	R,C	R,C	R,C	R,C	R,C				R,C	R,C	R,C	R,C	R,C							
-16	1"		R,C	R,C	R,C	R,C	R,C	R,C				R,C	R,C	R,C	R,C	R,C							
-20	1.1/4"	B	B	B	B									B									
-24	1.1/2"	B	B	B	B																		
-32	2"	B	B	B	B																		
-40	2.1/2"									C													
-48	3"																						

TECHNICAL



RYCO

HOSE SIZE SELECTION NOMOGRAPH

INDICATING FLOW CAPACITY OF HOSE ASSEMBLIES AT RECOMMENDED FLOW VELOCITIES

SELECTING THE RIGHT HOSE SIZE

With this nomograph, you can easily select the correct Hose ID size, Desired Flow Rate and Recommended Flow Velocity. If any two of these factors are known, the third can be determined.

TO USE THIS NOMOGRAPH:

1. Pick the two known values.
2. Lay a straightedge to intersect the two values.
3. Intersection on the third vertical line gives the value of that factor.

Example: To find the bore size for a Pressure Line consistent with a Flow Rate of 100 litres per minute (26 US or 22 Imperial gallons per minute), and a Flow Velocity of 4,5 metres per second (14.8 feet per second), connect Flow Rate to Flow Velocity and read Hose Bore on centre scale.

ANSWER: THE LINE CROSSES HOSE BORE BETWEEN -12 AND -16 ON "ALL OTHER DASH SIZES" SIDE OF HOSE BORE AXIS, SO A -16 HOSE IS REQUIRED. IF SURVIVOR/R5 OR T5 HOSE IS TO BE USED, FOR THIS EXAMPLE -16 WOULD ALSO BE REQUIRED.

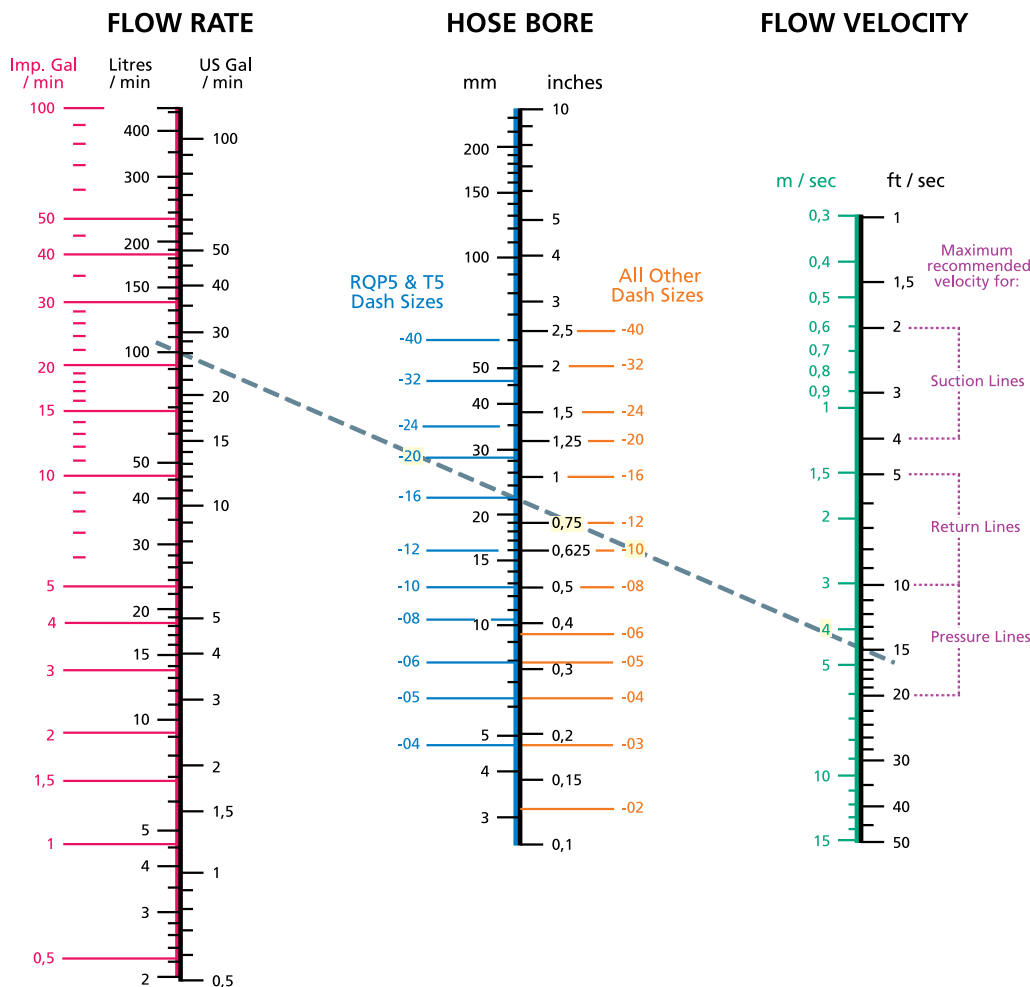

The velocity of the fluid should not exceed the range shown in the right hand column. When oil velocities are higher than recommended in the chart, turbulent flow occurs, resulting in loss of pressure and excessive heating. For long hoses and/or high viscosity oil, or if the flow of hydraulic fluid is continuous, it is recommended to use figures at the lower end of the Maximum Recommended Velocity range. For short hoses and/or low viscosity oil, or if the flow of hydraulic fluid is intermittent or for only short periods of time, figures at the higher end of the Maximum Recommended Velocity range can be used.

A FURTHER EXAMPLE WILL HELP YOU TO USE THIS CHART:

Determine the hose size required to carry 40 litres of oil per minute and determine the velocity of the oil through the hose assembly. The assembly is to be used as a pressure line and the flow will be continuous.

Locate the flow, 40 litres per minute (left hand column), and velocity, 15 feet per second (right hand column), since 15 is the centre of the Pressure Lines Maximum recommended velocity range. Lay a straight edge across these two points.

The straight edge crosses the centre column just above the -08 on "All Other Dash Sizes" side of Hose Bore axis. Keeping the straight edge on 40 litres per minute, cross the centre column at -08 and -10 sizes and read the Flow Velocity in the right hand column. It can be seen that using -08 Hose Size, Flow Velocity will be 18 feet per second, and for -10 Hose Size, Flow Velocity will be 11 feet per second. As the flow is continuous, -10 Hose Size is recommended.

HOSE ASSEMBLIES OF SPECIFIC LENGTHS

All Ryco hose assemblies are manufactured seat to seat length unless otherwise specified by customer. The length of a Hose Assembly can be measured in three ways:

INTRODUCTION

HOSES

TECHNICAL

1. SEAT TO SEAT LENGTH. (RYCO STANDARD, UNLESS OTHERWISE SPECIFIED).

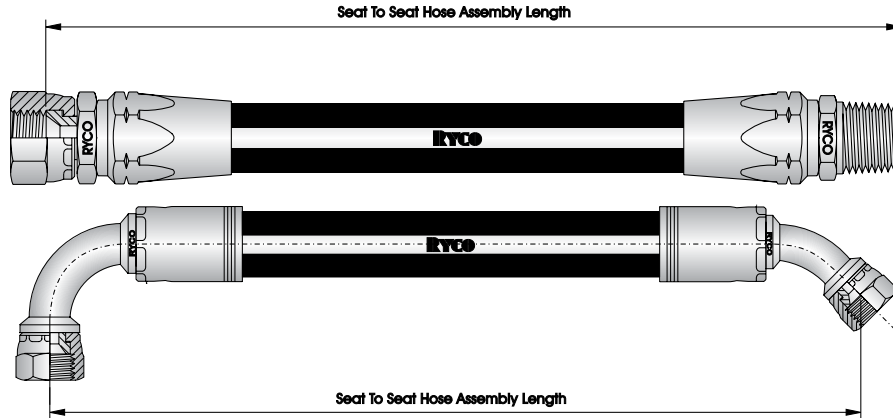

Length is measured from tip of seat to tip of seat.

2. OVERALL LENGTH. (OA)

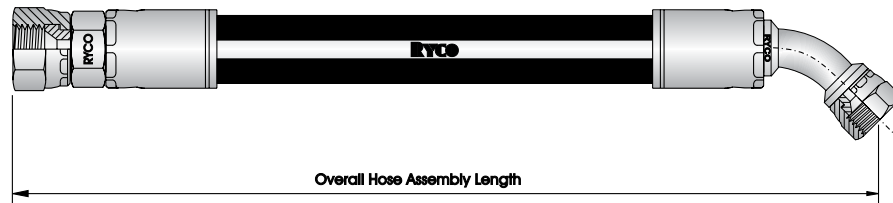

Length is measured from tip of nut to tip of nut.

3. CUT HOSE LENGTH. (CL)

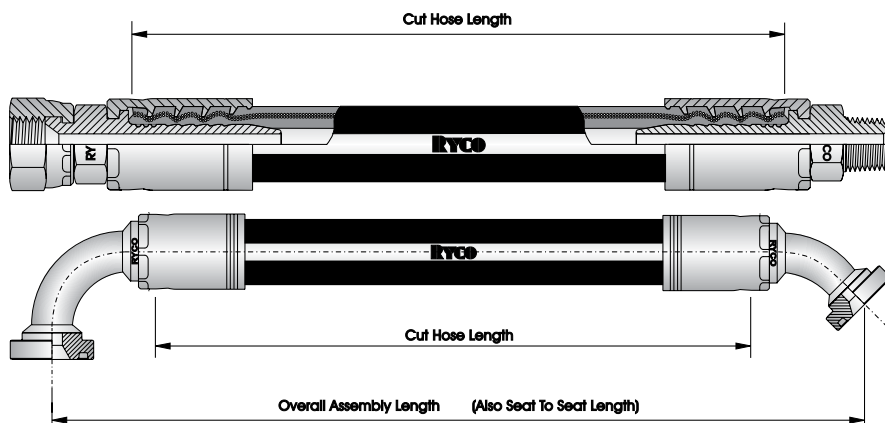

This is the length that the hose is cut to before couplings are attached. The length of the couplings is extra.

NOTE: For male fittings and flanged fittings, seat and overall length measurement points are the same.

ORIENTATION OF FITTINGS.

Proper positioning of elbow end fittings on a hose is governed by the offset angle, or the amount of angular offset between connecting parts in the installation. If this angle of orientation is not correct in the construction of a hose assembly the performance and life of the assembly will be greatly reduced.

Orientation is determined by the number of degrees between the fitting furthest from the viewer and the fitting nearest to the viewer, measured in a clockwise direction.

ORIENTATION TOLERANCES:
 ± 3° on lengths up to 600 mm (24").
 ± 5° on lengths over 600 mm (24").

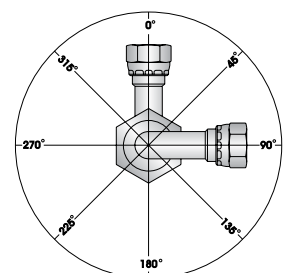

HOW TO ORDER HOSE ASSEMBLIES

When ordering Hose Assemblies, specifying by the following system will assist; or alternatively supply a clear, concise drawing or sketch.

1. **Hose Type.**
2. **(Hose Protection or extra operations to hose)** - if applicable.
3. **Hose Assembly Length** (expressed in mm), followed by method of measurement:
blank if "Seat to Seat Length"
-OA if "Overall Length"
-CL if "Cut Hose Length"
4. **Fitting End 1.**
5. **Fitting End 2.**
6. **Angle of Orientation** if both fittings are elbows and/or tube bends.

EXAMPLES:

1. **T3008D * 1830 * T2090-0808 * T2040-0814** – Hose will be made 1830 mm Seat to Seat.
2. **T3008D * 1830-OA * T2090-0808 * T2040-0814** – Hose will be made 1830 mm tip of T2090 male to tip of T2040 nut.
3. **T28D * 1830 * T2050-0808 * T2730-0824 @ 135°** – Hose assembly will be manufactured so that when T2050-0808 is furthest away the T2730-0824 will be oriented 135° clockwise.
4. **T5008D * 1640-CL * L010-0812 * L040-0817** – Hose will be cut to 1640 mm and length of fittings will be extra.
5. **H6012D * (RSG-32 * 1000) * 1000-OA * T7630-1236 * T7720-1236** – Hose will be covered with RSG for full length of hose assembly. Length will be overall from T7630 tip to T7720 bend centreline.
6. **SURVIVOR/212 * (PIERCE * 2200) * 2200 * T2090-1212 * T2040-1217** – Hose cover will be pierced/pin pricked.
7. **T18D * 1830 * T2010-0808 * T2020-0808 + S27-0808** – The length of the S27-0808 is extra, not included in the 1830 mm.

CUT-OFF ALLOWANCE (CA)

Values for Cut-off Allowance (CA) dimensions are published in this Product Technical Manual.

CA dimensions allow calculation of the Hose Cut Length required to make a Hose Assembly of a particular Seat to Seat Length.

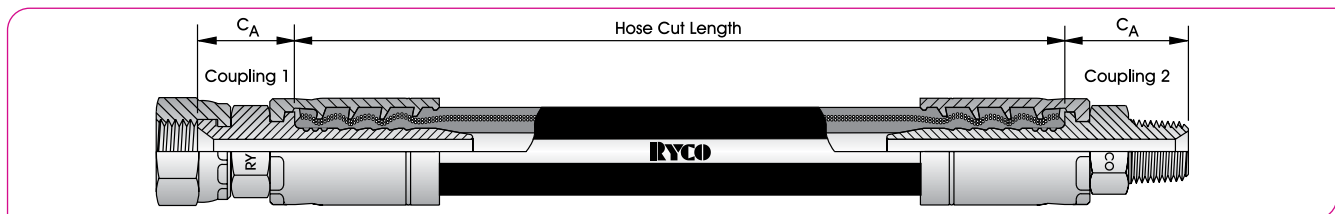

EXAMPLE:

For a Hose Assembly using **T2040-0609** coupling one end, and **T2090-0606** coupling other end, with a required Seat to Seat Length of 750 mm, calculate the Hose Cut Length required.

From page 203, CA dimension for T2040-0609 is 22 mm. This is "coupling 1" for the required hose assembly.

From page 199, CA dimension for T2090-0606 is 33 mm. This is "coupling 2" for the required hose assembly.

$$\text{Cut Length of Hose} = \text{Seat to Seat Length of Hose Assembly} - \text{CA (coupling 1)} - \text{CA (coupling 2)} = 750 \text{ mm} - 22 \text{ mm} - 33 \text{ mm} = 695 \text{ mm}$$

IMPORTANT NOTES:

1. CHECK AND MEASURE COUPLING BEFORE CUTTING HOSE

For all Couplings, before calculating the Cut Length of the hose, measure and check that the CA dimension of the physical coupling complies with that published. CA dimensions may vary due to manufacturing method or design refinement.

2. HOSE ASSEMBLY LENGTH GROWTH AFTER COUPLING ATTACHMENT

The CA dimension is measured from where the hose abuts when fully inserted, to the connection end seat of the coupling. With most Crimp Couplings¹, and Field Attachable Couplings having ferrules²; due to compression of the hose within the coupling after attachment, a growth in length occurs, in addition to the published CA dimension. Growth varies with different types and sizes of hose and couplings. For longer hoses, and non-critical applications, it is common practice to ignore the growth, as the extra length generated usually does not affect the function of the hose assembly. In applications where the length of the hose assembly is critical, the growth must be allowed for when calculating Cut Length of hose. Ryco recommends measuring the growth when the first coupling is attached by measuring between reference points marked on the coupling and hose before and after coupling attachment, then adjusting the Cut Length of the hose to compensate.

3. See page 355 for extra information about CA dimensions for K000, L000, M000 and P000 Series Field Attachable couplings.

4. See note on page 188 regarding Drop Length (DL) and Cut-off Allowance (CA) published dimensions.

5. For Hose Assemblies, the following must be considered: Maximum Working Pressure of the Hose; End Style (Connector Termination), see pages 496 to 500 and Minimum Free Length, see page 473 in the "Safety Guide", pages 471 to 473

Note:

1) For T4000 Series couplings with SRX/HT and SRF/P hose series, growth varies and must be measured each time.

2) For practical purposes, 8000 Series Push-On and 33000 Series couplings do not experience extra growth.

SELECTION, INSTALLATION AND MAINTENANCE OF HOSE AND HOSE ASSEMBLIES

SCOPE:

1. Many factors affect the selection, making, installation and maintenance of hose assemblies. This catalogue, Ryco Hydraulics (Ryco), and The Society of Automotive Engineers recommended practice SAE J1273, have useful information about selecting, making, installing and servicing hydraulic hose assemblies. For further information, please contact your local Ryco representative.

Ryco recommends hose and coupling combinations in the catalogue only after completing extensive testing. Evaluation of a hose and coupling combination requires considerable impulse testing and cannot be determined by a simple burst or pressure hold test. Ryco disclaims all liability for any hose assembly made in violation of Ryco recommendations, procedures and current crimp data. Crimp data is updated from time to time.

The consumer's exclusive remedy with respect to any claim shall be a refund of the purchase price or replacement of the product at the option of Ryco. In no event shall Ryco be liable for any incidental or consequential damages whatsoever.

WARNING: IMPROPER SELECTION, INSTALLATION, OR MAINTENANCE MAY RESULT IN PREMATURE FAILURES, BODILY INJURY, PROPERTY DAMAGE.

SELECTION:

2. The following is a list of factors which must be considered before final hose selection can be made:
 - 2.1 **Internal Pressure** – After determining the system pressure, hose selection must be made so that the recommended maximum operating pressure is equal to or greater than the system pressure. Surge pressures higher than the maximum operating pressure will shorten hose life and must be taken into account by the hydraulic engineer. Hose fitting rated pressures should also be considered, as the maximum working pressure is based on the whole hose assembly and not just the hose alone.
 - 2.2 **External Pressure** – In certain applications the external environmental pressures may exceed the fluid pressure inside the hose, therefore these factors need to be considered.
 - 2.3 **Suction** – Hoses used for suction applications must be selected to ensure that the hose will withstand the vacuum and pressure of the system.
 - 2.4 **Temperature** – Care must be taken to ensure that fluid and ambient temperatures, both static and transient, do not exceed the limitations of the hose. Special care must be taken when routing near hot objects such as manifolds.
 - 2.5 **Fluid Compatibility** – Hose selection must assure compatibility of the hose tube, cover, and fittings with the fluid used. Additional caution must be observed in hose selection for gaseous applications. For full compatibility table please refer to page "Chemical Compatibility for Hose" on page 477 in the Technical Section of this manual.
 - 2.6 **Size** – Transmission of power by means of pressurised fluid varies with pressure and rate of flow. The size of the components must be adequate to keep pressure losses to a minimum and avoid damage to the hose due to heat generation or excessive turbulence.
 - 2.7 **Routing** – Attention must be given to optimum routing to minimise inherent problems.
 - 2.8 **Environment** – Care must be taken to ensure that the hose and fittings are either compatible with, or protected from, the environment to which they are exposed. Environmental conditions such as ultraviolet light, ozone, salt water, chemicals and air pollutants can cause degradation and premature failure and, therefore, must be considered.
 - 2.9 **Mechanical Loads** – External forces can significantly reduce hose life. Mechanical loads which must be considered include excessive flexing, twist, kinking, tensile or side loads, bend radius, and vibration. Use of swivel type fittings or adaptors may be required to ensure no twist is put into the hose. Unusual applications may require special testing prior to hose selection.
 - 2.10 **Abrasion** – While a hose is designed with a reasonable level of abrasion resistance, care must be taken to protect the hose from excessive abrasion which can result in erosion, snagging, and cutting of the hose cover. Exposure of the reinforcement will significantly accelerate hose failure.
 - 2.11 **Proper End Fitting** – Care must be taken to ensure proper compatibility exists between the hose and coupling selected based on the manufacturer's recommendations substantiated by testing to industry standards such as SAE J517.
 - 2.12 **Length** – When establishing proper hose length; motion absorption, hose length changes due to pressure, as well as hose and machine tolerances must be considered.
 - 2.13 **Specifications and Standards** – When selecting hose; government, industry, and manufacturer's specifications and recommendations must be reviewed as applicable.
 - 2.14 **Hose Cleanliness** – Hose components vary in cleanliness levels. Care must be taken to ensure that the assemblies selected have an adequate level of cleanliness for the application.
 - 2.15 **Electrical Conductivity** – Certain applications require that hose be non-conductive to prevent electrical current flow. Other applications require the hose to be sufficiently conductive to drain off static electricity. Hose and fittings must be chosen with these needs in mind.
 - 2.16 **High Pressure Gas** – Do not use hydraulic hose to transmit high pressure gases.

- 2.17 **Vibration** - Vibration can reduce hose service life. If necessary, conduct tests to evaluate the effects of frequency and amplitude of system vibration on a hose assembly. Clamps or other devices may be used to reduce the effects of vibration.

INSTALLATION:

3. After selection of proper hose, the following factors must be considered by the installer:
- 3.1 **Pre-installation Inspection** – Prior to installation, a careful examination of the hose must be performed. All components must be checked for correct style, size and length. In addition, the hose assembly, and each of the individual components comprising the assembly, must be examined for cleanliness, I.D. obstructions, blisters, loose cover, or any other visible defects.
 - 3.2 **Follow Manufacturer's Assembly Instructions.**
 - 3.3 **Minimum Bend Radius** – Installation at less than minimum bend radius may significantly reduce hose life. Particular attention must be given to preclude sharp bending at the hose/fittings juncture which may result in leaking, hose rupturing, or the hose assembly blowing apart.
 - 3.4 **Lengths:** Unnecessarily long hose can increase pressure drop and affect system performance. When pressurised, hose that is too short may pull loose from its fittings, or stress the hose fitting connections, causing premature metallic or seal failures.
 - 3.5 **Twist Angle and Orientation** – Hose installations must be such that relative motion of machine components produces bending of the hose rather than twisting.
 - 3.6 **Securement** – In many applications, it may be necessary to restrain, or guide, the hose to protect it from damage by unnecessary flexing, pressure surges, and contact with other mechanical components. Care must be taken to ensure such restraints do not introduce additional stress or wear points.
 - 3.7 **Proper Connection of Ports** – Proper physical installation of the hose requires a correctly installed port connection while ensuring that no twist or torque is transferred to the hose.
 - 3.8 **Avoid External Damage** – Proper installation is not complete without ensuring that all tensile loads, side loads, kinking, flattening, potential abrasion, thread damage, or damage to sealing surfaces are corrected or eliminated.
 - 3.9 **System Check out** – After completing the installation, all entrapped air must be eliminated, then the system must be pressurised to the maximum system pressure and checked for proper function, and for freedom from leaks.

NOTE: AVOID POTENTIAL HAZARDOUS AREAS WHILE TESTING.

MAINTENANCE:

4. Even with proper selection and installation, hose life may be significantly reduced without a continuing maintenance program. Maintenance and Inspection frequency should be determined by the severity of the application and risk potential. A maintenance program should include the following as a minimum.
- 4.1 **Hose Storage** – Hose products in storage can be adversely affected by temperatures, humidity, ozone, sunlight, oils, solvents, corrosive liquids and fumes, insects, rodents, radioactive materials, sharp edges and abrasive surfaces, electric or strong magnetic fields, mould and fungi. Storage areas should be relatively cool and dark and free of dust, dirt, dampness and mildew. Store hose in a manner that facilitates age control and first-in, first-out usage based on manufacturing date on hose or hose assembly.
 - 4.2 **Visual Inspection** – Any of the following conditions require immediate system shut down and replacement of the hose assembly:
 - a) Leaks at fittings or in hose. (Leaking fluid is a fire hazard.)
 - b) Damaged, cut, or abraded cover. (Any reinforcement exposed.)
 - c) Kinked, crushed, flattened, or twisted hose.
 - d) Hard, stiff, heat cracked, or charred hose.
 - e) Blistered, soft, degraded, or loose cover.
 - f) Cracked, damaged, or badly corroded fittings.
 - g) Slippage or movement of fittings on the hose.
 - 4.3 **Visual Inspection** – The following items must be tightened, repaired or replaced as required.
 - a) Leaking port conditions.
 - b) Clamps, guards, shields.
 - c) Remove excessive dirt build-up.
 - d) System fluid level, fluid type, and any air entrapment.
 - 4.4 **Functional Test** – Operate the system at maximum operating pressure and check for possible malfunctions and freedom from leaks.
- NOTE: AVOID POTENTIAL HAZARDOUS AREAS WHILE TESTING.**
- 4.5 **Replacement Intervals** – Specific replacement intervals must be considered based on previous service life, government or industry recommendations, or when failures could result in unacceptable down time, damage, or injury risk.



SAFETY GUIDE

FOR THE SELECTION AND USE OF HOSE, FITTINGS AND RELATED ACCESSORIES

Failure or improper selection or improper use of hose, fittings, or related accessories can cause death, personal injury and property damage. Possible consequences of failure or improper selection or improper use of hose, fittings, or related accessories include, but are not limited to:

- Fittings blown off at high speed.
- High velocity fluid discharge.
- Explosion, or burning, of the conveyed fluid.
- Electrocution from high voltage electric power lines or other sources of electricity.
- Contact with suddenly moving, or falling, objects that are held in position, or moved, by conveyed fluid.
- Injections by high-pressure fluid discharge.
- Dangerously whipping hose.
- Contact with conveyed fluids that may be hot, cold, toxic or otherwise injurious.
- Sparking or explosion caused by static electricity build-up.
- Sparking, or explosion, while spraying paint or other flammable liquid.

1. GENERAL INSTRUCTIONS:

- 1.1 **Scope:** This safety guide provides instructions for selecting and using (including assembling, installing and maintaining) hose fittings (including all products commonly called “fittings” or “couplings” for attachment to hose), and related accessories (including crimping machines and tooling). This safety guide is to be used in conjunction with the specific publications for the specific hose, fittings and related accessories that are being considered for use.
- 1.2 **Fail-Safe:** Hose and hose assemblies can and do fail. Design all systems in a fail-safe mode, so that failure of the hose or hose assembly or related accessories will not endanger persons or property.
- 1.3 **Distribution:** Provide a copy of this safety guide to each person who is responsible for selecting, or using, hose and fittings and related accessories. Do not select, or use, hose and fittings or related accessories without thoroughly understanding this safety guide.
- 1.4 **User Responsibility:** Due to the wide variety of operating conditions and uses for hose and fittings and related accessories, Ryco do not represent or warrant that any particular hose or fitting or related accessories is suitable for any specific end use. This safety guide does not analyse all technical parameters that must be considered in selecting a product. The product user, through its own analysis and testing, is solely responsible for:
 - The final selection of the hose and fittings and related accessories.
 - Assuming that requirements are met and the use presents no health or safety hazards.
 - Providing all appropriate health and safety warnings where hose and fittings and related accessories are used.
- 1.5 **Additional Questions:** Contact the Ryco Hydraulics Technical Department if you have any questions or require any additional information.

2. HOSE AND FITTING SELECTION INSTRUCTIONS:

- 2.1 **Electrical Conductivity:** Certain applications require that a hose be non-conductive to prevent electrical current flow. Other applications require the hose to be sufficiently conductive to drain off static electricity. Extreme care must be exercised when selecting hose and fittings for these or any other applications. For applications that require hose to be electrically non-conductive, including but not limited to applications near high voltage electric lines, only special non-conductive hose can be used. The manufacturer of the equipment must be consulted to be certain that the hose and fittings selected are correct for the application. Do not use any Ryco hose or fittings for any such application unless:
 - (i) the application is expressly approved by Ryco
 - (ii) the hose is both orange colour and marked “non-conductive”
 - (iii) the manufacturer of the equipment specifically approves the particular Ryco hose and fittings.

Do not use any Ryco hose or fittings for conveying paint in airless spraying or similar applications without the written approval of Ryco in each case. A special hose and fittings assembly is required for this application. If the correct hose and fitting application is not used for this application, static electricity can build up and cause sparks that may result in an explosion and/or fire.

The electrical conductivity or non-conductivity of hose and fittings is dependent upon many factors and may be susceptible to change.
- 2.2 **Pressure:** Hose selection must be made so that the published maximum recommended working pressure of the hose is equal or greater than the maximum system pressure. Surge pressures in the system higher than the published maximum recommended working pressure will cause failure, or shorten hose life.
- 2.3 **Suction:** Hoses used for suction applications must be selected to ensure that the hose will withstand the vacuum and pressure of the system.
- 2.4 **Temperature:** Be certain that fluid and ambient temperatures, both steady and transient, do not exceed the limitations of the hose. Care must be taken when routing hose near hot objects such as manifolds.
- 2.5 **Fluid Compatibility:** Hose selection must assure compatibility of the hose tube, cover, reinforcement, and fittings with the fluid media used.

- 2.6 **Permeation:** Permeation (that is, seepage through the hose) will occur from inside the hose to the outside environment when hose is used with gases, liquid and gas fuels, and refrigerants (including but not limited to such materials such as helium, fuel, oil, natural gas or freon). This permeation may result in high concentrations of vapours which are potentially flammable, explosive, or toxic, and in loss of fluid. You must take into account the fact that permeation will occur and could be hazardous.
- Permeation of moisture from the outside environment to inside the hose will also occur. If this moisture permeation would have detrimental effects (particularly for, but not limited to, refrigeration and air conditioning systems), incorporation of appropriate system safeguards should be selected and used. Rubber hoses should not be painted without consulting Ryco first.
- 2.7 **Size:** Transmission of power by means of pressurised fluid varies with pressure and rate flow. The size of the components must be adequate to keep pressure losses to a minimum and avoid damage due to heat generation of excessive fluid velocity.
- 2.8 **Routing:** Attention must be given to optimum routing to minimise inherent problems.
- 2.9 **Environment:** Care must be taken to ensure that the hose and fittings are either compatible with or protected from the environment to which they are exposed including but not limited to ultraviolet radiation, sunlight, heat, ozone, moisture, water, salt water, chemicals and air pollutants.
- 2.10 **Mechanical Loads:** Consideration must be given to excessive flexing, twist, kinking, tensile or side loads, bend radius, and vibration. Use of swivel type fittings or adaptors may be required.
- 2.11 **Physical Damage:** Care must be taken to protect hose from wear, snagging and cuts.
- 2.12 **Proper End Fittings:** See instructions 3.2 through 3.5. These recommendations may be substantiated by testing to industry standards.
- 2.13 **Length:** When establishing a proper hose length; motion absorption, hose length changes due to pressure, and hose and machine tolerances must be considered.
- 2.14 **Specifications and Standards:** When selecting hose and fittings; government, industry, and Ryco specifications and recommendations must be reviewed and followed as applicable.
- 2.15 **Hose Cleanliness:** Hose components may vary in cleanliness levels. Care must be taken to ensure that the assembly selected has an adequate level of cleanliness for the application.
- 2.16 **Fire Resistant Fluids:** Some fire resistant fluids require the same hose as used with petroleum oil. Some use a special hose, while a few fluids will not work with any hose at all. See General Instructions 1.5 and Hose and Fitting Selection Instructions 2.5.
- 2.17 **Radiant Heat:** Hose can be heated to destruction without contact by nearby items such as hot manifolds or molten metal.
- 2.18 **Welding and Brazing:** Heating of plated parts, including hose fittings and adaptors, above 232°C (450°F) such as during welding, brazing, or soldering may emit deadly gases.
- 2.19 **Atomic Radiation:** Atomic radiation affects all materials used in hose assemblies. Do not expose hose assemblies to atomic radiation.

3. HOSE AND FITTING ASSEMBLY AND INSTALLATION INSTRUCTIONS:

- 3.1 **Pre-Installation Inspection:** Prior to installation, a careful examination of the hose assembly must be performed. All components must be checked for correct style, size, and length. The hose must be examined for cleanliness, obstructions, blisters, cover looseness, or any other visible defects.
- 3.2 **Hose and Fitting Assembly:** Do not assemble a Ryco fitting on a Ryco hose that is not specifically listed for that fitting by Ryco. Do not assemble Ryco fittings on another manufacturer's hose or a Ryco hose on another manufacturer's fitting unless Ryco approves the assembly in writing, and the user verifies the assembly and the application through analysis and testing. See instruction 1.4. The Ryco published instructions must be followed for assembling the fittings on the hose. These instructions are provided in the Ryco catalogue.
- 3.3 **Related Accessories:** Do not crimp or swage any Ryco hose or fitting with anything but the proper Ryco swage machine or crimp machine and in accordance with Ryco published instructions. Do not crimp or swage another manufacturer's hose fitting with a Ryco crimp machine or swage machine unless authorised in writing by Ryco.
- 3.4 **Safety Equipment:** During fabrication, use proper safety equipment, including eye protection, respiratory protection, and adequate ventilation.
- 3.5 **Reuse of Hose and Fittings:** Damaged hoses or hose fittings shall not be used.
- 3.6 **Assembly inspection:** After assembly, hose assemblies shall be inspected for visible defects and interior obstructions, such as tube bulges, etc.
- 3.7 **Marking:** Hose assemblies shall be marked in accordance with any relevant standards.
- 3.8 **Parts:** Do not use any Ryco hose or fitting part unless used with the correct Ryco mating parts, in accordance with published instructions, unless authorised in writing by Ryco.
- 3.9 **Field Attachable/Permanent:** Field Attachable couplings may be reattached once only after their first use, provided that they have not been part of a hose assembly that has failed, and are in a fit condition for reuse. Do not reuse any field attachable hose coupling that has blown or pulled off a hose. Do not reuse any permanent (that is, crimped or swaged) hose fittings or any part thereof.

- 3.10 **Minimum Bend Radius:** Installation of a hose at less than the minimum listed bend radius may significantly reduce hose life.
- 3.11 **Twist Angle and Orientation:** Hose installations must be such that relative motion of machine components does not produce twisting.
- 3.12 **Securement:** In many applications, it may be necessary to restrain, protect, or guide the hose to protect it from damage. Care must be taken to ensure such restraints do not introduce additional stress or wear points.
- 3.13 **Proper Connection of Ports:** Proper physical installation of the hose requires a correctly installed port connection while ensuring that no twist or torque is transferred to the hose.
- 3.14 **Assembly Torque:** The correct torque instructions and specifications must be followed to obtain a proper seal when a hose assembly is attached to a port, an adaptor or another assembly.
- 3.15 **External Damage:** Proper installation is not complete without ensuring that tensile loads, side loads, kinking, flattening, potential abrasion, thread damage, or damage to sealing surfaces are corrected or eliminated. See instruction 2.10.
- 3.16 **System Check-out:** After completing the installation, all air entrapment must be eliminated and the system pressurised to the maximum system pressure and checked for proper function and freedom from leaks.
NOTE: Avoid potential hazardous areas while testing.
- 3.17 **Minimum Free Length of Hose Assemblies:** Occasionally requests or orders arise for hydraulic hose assemblies where the 'Free Length' of hose between the ferrules of the couplings is not long enough, and could hinder the ability of the hose assembly to function properly. This is particularly the case when utilising very short hose assemblies, where a shortening or shrinkage of the hose under pressure may result in hose and coupling separation. In addition, small misalignments, vibration and other displacements may induce very high stresses upon the hose/coupling juncture, as there is little capacity for the flexible nature of the hose to compensate.

Due to the possible problems associated with using very short hose assemblies, Ryco has adopted the following general rule (equation) for the allowable Minimum Free Length (MFL) of hose to be used as a guide when fabricating or ordering a hydraulic hose assembly.

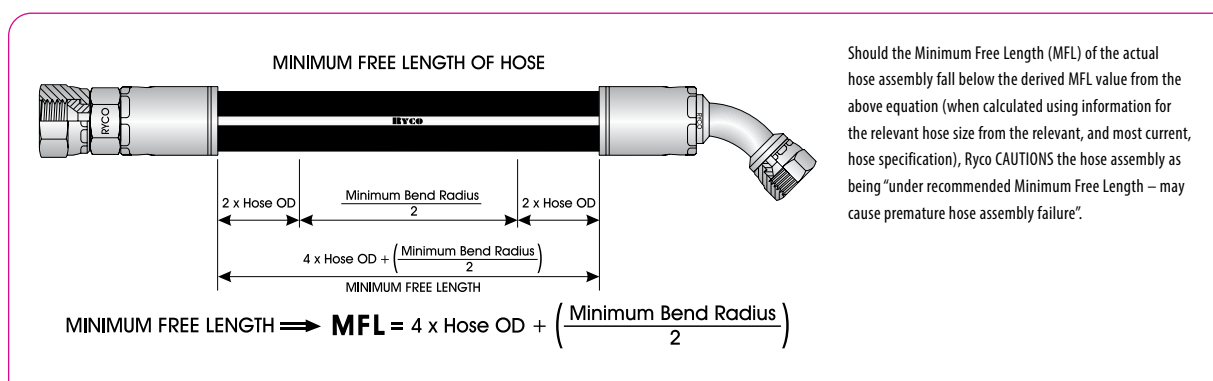

4. HOSE AND FITTING MAINTENANCE INSTRUCTIONS:

Even with proper selection and installation, hose life may be significantly reduced without a continuing maintenance program. Frequency should be determined by the severity of the application and risk potential. A maintenance program must include the following as a minimum.

- 4.1 **Visual Inspection Hose/Fitting:** Any of the following conditions require immediate system shut down and replacement of the hose assembly:
 - Slippage or movement of fittings on the hose
 - Damaged, cut or abraded cover
 - Hard, stiff, heat cracked, or charred hose
 - Cracked, damaged, or badly corroded fittings
 - Leaks at fitting or in hose
 - Kinked, crushed, flattened or twisted hose
 - Blistered, soft, degraded or loose cover
 - Unusual noise, odour or heat
- 4.2 **Visual Inspection All Other:** The following items must be tightened, repaired or replaced as required:
 - Leaking port conditions
 - Remove excess dirt build-up
 - Clamps, guards, shields
 - System fluid level, fluid type and any air entrapment
- 4.3 **Functional Test:** Operate the system at maximum operating pressure and check for possible malfunctions and freedom from leaks.
- 4.4 **Replacement Intervals:** Specific replacement intervals must be considered based on previous service life, government or industry recommendations. See instructions 1.2.

Some Ryco Hose Series are not listed on page 58: **RTH1, MP1**.

These Hoses are specific purpose Hoses, and their temperature limits are specified in the Hose Section of this Product Technical Manual. Contact Ryco Technical Department for any further queries.

Other Ryco Hose Series are listed on page 58. The Maximum Working Temperatures for these hoses, as listed in the Hose Section of this Product Technical Manual are for use with general purpose, mineral (petroleum) oil based hydraulic fluids, except where otherwise stated. Temperature limits for other hydraulic fluids, and some other common applications, are listed on page 58.

CAUTION:

Life expectancy of hoses is shortened at high temperatures. Detrimental effects increase when temperature is elevated, and also when; operating pressure, flow velocity, duration and frequency of exposure, and level of impurities in the media are high. Actual service life at temperatures approaching the recommended limits will depend on the particular application and the fluid being used.

Maximum Working Temperatures refer to the temperature of the media in the hose; not the environmental temperature around the outside of the hose. Please contact Ryco Technical Department for environmental temperatures in excess of 80°C (176°F), except **SURVIVOR/1, SURVIVOR/2, and SURVIVOR/R5** where environmental temperature is the same as media temperature.

Maximum Working Temperatures shown are for continuous temperatures. Slightly higher intermittent temperatures (up to 10% of time) may be acceptable with some hoses and some fluids, if reduced service life is acceptable. Please contact Ryco Technical Department for more information.

DO NOT expose Hose to Maximum Temperature and Maximum Working Pressure at the same time.

The fluid manufacturer's recommended maximum operating temperature for the fluid must not be exceeded. If different to the temperatures listed in the following table, the lower limit must take precedence. We recommend keeping the hose filled with the pressure medium at all times. Further information available on request.

SAFETY GUIDE – MAXIMUM TEMPERATURE LIMITS

HOSE COVER	GROUP 1	GROUP 2	GROUP 3	GROUP 4	GROUP 5
ENERGY	E1, E2, EC1, EC2, DK1E, DK2E				
DIEHARD	T3000D, T4000D, T5000D, T6000D, T1D, T2D, TXA2D, DF1D, DF2D, DK1D, DK2D, TJ2D, PL1D	H3000D, H4000D, H5000D, H6000D, C6000D, H12D, D4000D			
SLIDER	T3000S, T4000S, T5000S, T6000S, T1S, T2S, DK1S, DK2S	H3000S, H4000S, H5000S, H6000S, C6000S, H12S			
SURVIVOR	BT1 ***	D2B	SURVIVOR/1, SURVIVOR/2		
ICEBREAKER	M2G, M1, RTH1, MP1				T3600C, H5000C, T2C
OTHER SERIES	SRF/P, SRX/HT, M2, T5, T1F, PL1PV, CS1000, MS1000		SURVIVOR/R5	TP7, TP7N, TP7T, TP7TN, TP8, TP8N, TP8T, TP8TN, TP3000, TPLG	

MEDIA	TEMPERATURE LIMITS				
-------	--------------------	--	--	--	--

GENERAL PURPOSE MINERAL PETROLEUM BASED HYDRAULIC OIL¹	"-40°C TO +100°C -40°F TO +212°F"	"-40°C TO +121°C -40°F TO +250°F"	"-40°C TO +135°C -40°F TO +275°F -40°F TO +275°F"	"-40°C TO +95°C -40°F TO +203°F"	"-60°C TO +100°C -76°F TO +212°F"
WATER	"0°C TO +71°C +32°F TO +160°F"	"0°C TO +71°C +32°F TO +160°F"	"0°C TO +70°C +32°F +158°F"	"0°C TO +70°C +32°F +250°F"	"0°C TO +71°C +32°F TO +160°F"
WATER IN MINERAL OIL 40% to 80% water	"-40°C TO +85°C -40°F TO +185°F"	"-40°C TO +85°C -40°F TO +185°F"	"0°C TO +70°C +32°F +158°F"	"-40°C TO +70°C -40°F TO +158°F"	"-60°C TO +80°C -60°F TO +176°F"
MINERAL OIL IN WATER more than 80% water	"-40°C TO +85°C -40°F TO +185°F"	"-40°C TO +85°C -40°F TO +185°F"	"0°C TO +70°C +32°F +158°F"	"-40°C TO +70°C -40°F TO +158°F"	"-60°C TO +80°C -60°F TO +176°F"
WATER/GLYCOL	"-40°C TO +85°C -40°F TO +185°F"	"-40°C TO +85°C -40°F TO +185°F"	"-40°C TO +70°C -40°F TO +158°F"	"-40°C TO +70°C -40°F TO +158°F"	"-60°C TO +80°C -60°F TO +176°F"
GLYCOL	"-40°C TO +85°C -40°F TO +185°F"	"-40°C TO +85°C -40°F TO +185°F"	"-40°C TO +85°C -40°F TO +185°F"	"-40°C TO +70°C -40°F TO +158°F"	"-60°C TO +80°C -60°F TO +176°F"
PHOSPHATE ESTERS	NOT SUITABLE	NOT SUITABLE	NOT SUITABLE	"40°C TO +70°C -40°F TO +158°F SEE NOTE 2"	NOT SUITABLE
AIR³	"-40°C TO +71°C -40°F TO +160°F"	"-40°C TO +71°C -40°F TO +160°F SEE NOTE 3"	"-40°C TO +135°C -40°F TO +275°F -40°F TO +212°F SEE NOTE 3"	"-40°C TO +71°C -40°F TO +160°F SEE NOTE 3"	"-60°C TO +71°C -60°F TO +160°F"
PETROL GASOLINE	CONTACT Ryco	CONTACT Ryco	CONTACT Ryco	CONTACT Ryco	CONTACT Ryco
DIESEL FUEL	"PL1D: -40°C TO +49°C -40°F TO +160°F T5: -40°C TO +71°C -40°F TO +160°F OTHERS: -40°C TO +50°C -40°F TO +122°F"	"-40°C TO +50°C -40°F TO +122°F"	"-40°C TO 70°C -40°F TO +158°F"		"-60°C TO +71°C -60°F TO +160°F"
ENGINE LUBRICATING OIL, GEARBOX OIL	"-40°C TO +100°C -40°F TO +212°F"	"-40°C TO +100°C -40°F TO +212°F"	"-40°C TO +135°C -40°F TO +275°F"	"-40°C TO +95°C -40°F TO +203°F"	"-60°C TO +80°C -60°F TO +176°F"
AUTOMATIC TRANSMISSION FLUID	"-40°C TO +100°C -40°F TO +212°F"	"-40°C TO +100°C -40°F TO +212°F"	"-40°C TO +135°C -40°F TO +275°F"	"-40°C TO +95°C -40°F TO +203°F"	"-60°C TO +80°C -60°F TO +176°F"

1. For highly refined and special purpose mineral based hydraulic oils (for example aviation hydraulic oils, MIL spec oils, etc), contact Ryco Technical Department.

2. Not suitable for use with aerospace type phosphate esters such as Monsanto Skydrol 500B, Stauffer Aero-Safe 2300W and Chevron Hy-jet IV.

3. For use with Air at pressures above 17,2 bar (250 psi), cover of hose must be perforated/pin-pricked (except SURVIVOR/R5 and T5), to allow air permeating through hose to escape without blistering the cover. Maximum working pressure of wire braid and spiral reinforced hose must be reduced by 30% (except for SURVIVOR/1 and SURVIVOR/2). Observe all State and Federal Safety Regulations.

TECHNICAL

CHARACTERISTICS OF HOSE ELASTOMERS

The characteristics shown below are for the normal, or usual, range of these specific Elastomers. Characteristics can be changed somewhat, through different compounding, to meet the requirements of specialised applications. Each elastomer has a unique combination of strengths and weaknesses. Depending on each specific application, the elastomer must possess the correct combination of properties if it is to perform satisfactorily.

Tube and cover elastomers may occasionally be upgraded to take advantage of improved materials and technology.

For detailed information on specific hose tube or cover check the Chemical Compatibility Table on page 477, and also the specific hose specifications page.

COMMON NAME Chemical Name	NEOPRENE Poly-Chloroprene	NITRILE Acrylonitrile & Butadiene	HYPALON™ Chlorosulfonated Polyethylene	EPDM Ethylene Propylene Diene	CPE Chlorinated Polyethylene	POLYESTER Polyamide Resin	TEFLON™ Fluorinated Thermoplastic
Common	CR	NBR	CSM	EPDM	CPE	PE-E	PTFE
Flame Resistance	Very Good	Poor	Good	Poor	Good	Poor	Good
Petroleum Base Oils	Good	Excellent	Very Good	Poor	Very Good	Very Good	Excellent
Diesel Fuel	Good to Excellent	Excellent	Good	Poor	Very Good	Very Good	Excellent
Resistance to Gas Permeation	Good	Good	Good to Excellent	Fair to Good	Good	Good	Good to Excellent
Weather	Good to Excellent	Fair to Good	Very Good	Excellent	Good	Excellent	Excellent
Ozone	Good to Excellent	Poor for Tube Good for Cover	Very Good	Excellent	Good	Good	Excellent
Heat	Good	Good	Very Good	Excellent	Excellent	Good	Excellent
Low Temperature	Fair to Good	Poor to Fair	Poor	Good to Excellent	Good	Good	Excellent
Water - Oil Emulsions	Excellent	Excellent	Good	Poor	Excellent	Very Good	Excellent
Water/Glycol Emulsions	Excellent	Excellent	Excellent	Excellent	Excellent	Very Good	Excellent
Phosphate Esters to 82°C (180°F)	Fair (For Cover)	Poor	Excellent (not for Aerospace types)	Very Good	Very Good	Good	Excellent
Phosphate Ester Base Emulsions	Fair (For Cover)	Poor	Excellent (not for Aerospace types)	Very Good	Very Good	Good	Excellent

NOTE: HYPALON™ and TEFLON™ are Trademarks of DUPONT

The following Chemical Compatibility Chart is for guidance only.
 In all cases, testing is advised to determine the application suitability.
 Material for Couplings and Adaptors must also be compatible - refer to Ryco Technical Department.
 Specified resistance applies only at room temperature unless otherwise stated, and within the listed concentration.

CHEMICAL NAME	TUBE MATERIAL						
	NEOPRENE	NITRILE	NITRILE PVC	CPE	HYPALON™	POLYESTER	TEFLON™
Acetic Acid (25%)	2	X	2	1	2	X	1
Acetone	X	X	X	1	X	X	1
Acetylene	NO HOSE AVAILABLE						
Air (71°C, 166°F)	1	1	1	1	1	1	1
Air (82°C, 180°F)	2	2	2	1	2	2	1
Air (93°C, 199°F)	X	X	X	1	2	X	1
Amyl Acetate	X	X	X	2	X	X	1
Aniline	X	X	X	2	X	-	1
Benzene (Benzol)	X	X	X	X	X	X	1
Butyl Acetate	X	X	X	2	X	X	1
Butyl Alcohol (Butanol)	2	X	X	1	2	2	1
Carbon Dioxide (Dry)	2	1	1	1	1	-	1
Carbon Dioxide (Wet)	2	1	1	1	1	-	1
Carbon Disulfide	X	X	X	2	X	-	1
Chlorine Gas (Dry & Wet)	NO HOSE AVAILABLE						
Chlorine Water (25%)	X	X	X	-	2	X	1
Chloroform	X	X	X	-	X	X	1
Cyclohexane	X	2	X	1	X	2	1
Diesel fuel (under 50°C, 122°F)	X	1	X	2	X	1	1
Ethers (under 50°C, 122°F)	X	2	2	1	2	X	1
Ethyl Acetate	X	X	X	2	X	2	1
Ethyl Alcohol (Ethanol)	1	1	-	1	1	2	1
Ethyl Cellulose	-	-	-	1	-	-	1
Ethyl Chloride (Wet)	2	X	X	-	X	-	1
Ethylene Glycol (under 66°C, 151°F)	1	1	1	1	1	1	1
Fluorine (Liquid)	NO HOSE AVAILABLE						
Formaldehyde 37%	2	2	-	1	2	2	1
Fuel A (ASTM)	X	2	2	1	1	-	-
Fuel B (ASTM)	X	2	X	2	X	-	-
Fuel Oil	X	1	X	1	X	2	1
Glycerine (Glycerol)	1	1	1	1	1	1	1
Grease (Petroleum Base)	2	1	2	-	2	1	1
Hexane (under 50°C, 122°F)	X	1	2	2	1	2	1
Hydraulic Fluid (Phosphate Ester Base)	X	X	X	1	1	2	1
Hydraulic Fluid (100°C, 212°F) (Std. Petroleum Oils)	2	1	2	1	1	1	1
Hydrochloric Acid (15%)	X	X	X	1	2	X	1
Hydrochloric Acid (37%)	X	-	X	1	2	X	1
Hydrogen (Gas)	1	1	-	1	-	2	1
Hydrogen Peroxide (30%)	X	2	X	1	2	X	1

CHEMICAL NAME	TUBE MATERIAL						
	NEOPRENE	NITRILE	NITRILE PVC	CPE	HYPALON™	POLYESTER	TEFLON™
Isopropyl Alcohol	2	2	2	1	2	-	1
Kerosene	X	2	X	1	X	2	1
L.P.G.	USE L.P.G. HOSE ONLY						
Lubricating Oils (under 50°C, 122°F)	2	1	2	1	2	1	1
Methyl Alcohol (Methanol) 100%	1	1	1	1	1	2	1
Methyl Chloride	X	X	X	X	X	2	1
Methyl Ethyl Ketone (MEK)	X	X	X	2	X	2	1
Naphtha (Low Aromatics)	X	2	X	1	X	X	1
Natural Gas	USE L.P.G. HOSE ONLY						
Nitric Acid (10%)	X	X	X	1	2	X	1
Nitric Acid (40%)	X	X	X	X	X	X	1
Oxalic Acid (10% cold)	X	X	X	1	2	X	1
Ozone (Dry)	2	X	2	1	2	2	1
Paint Solvents (Oil Base)	X	X	-	-	X	2	1
Perchloroethylene	X	X	X	2	X	X	1
Phenol (Carbolic Acid)	X	X	X	1	X	X	1
Phosphoric Acid (50%)	2	2	X	1	1	X	1
Propane Gas	USE L.P.G. HOSE ONLY						
Sodium Hydroxide (40%)	1	2	-	1	1	X	1
Sodium Hydroxide (50%, under 45°C, 113°F)	2	X	X	1	1	X	1
Sodium Hydroxide (50%, under 82°C, 180°F)	-	-	-	1	2	X	1
Sulphur Dioxide (Dry)	X	X	X	-	2	X	1
Sulphuric Acid (10%)	1	2	2	1	1	X	1
Sulphuric Acid (93%)	X	X	X	-	X	X	1
Toluene (Toluol)	X	X	X	X	X	2	1
Trichloroethylene	X	X	X	2	X	2	1
Vegetable Oils	2	1	2	1	2	1	1
Xylene	X	X	-	X	-	2	1

KEY

1 = Excellent Resistance
 2 = Good Resistance
 X = Not Recommended
 - = No Data Available

NOTE: HYPALON™ and TEFLON™ are Trademarks of DUPONT

FIELD ATTACHABLE NON-SKIVE HOSE ASSEMBLY

ASSEMBLY INSTRUCTIONS FOR:

Ryco FIELD ATTACHABLE COUPLINGS WITH MATCHED SIZES OF Ryco NON-SKIVE HOSE.

USE ONLY Ryco BT1, E2, SURVIVOR/1, SURVIVOR/2, SURVIVOR/R5, T1D, T1F, T2D, TXA2D, T5 and TPGL SERIES HOSE.

STEP ONE



- Cut hose to length required using a cut-off saw.
- Ensure hose is cut squarely.
- Clean hose bore.

STEP TWO

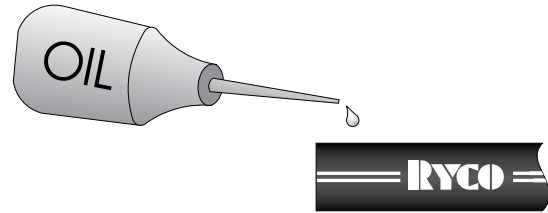

- Lightly lubricate outer cover.

STEP THREE

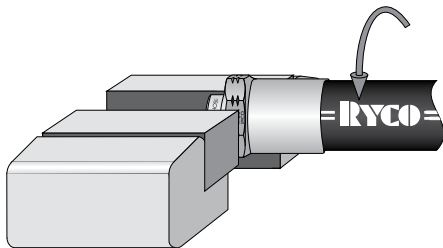

- Screw anti-clockwise until hose bottoms in ferrule.
- Ease back between 1/2 and 3/4 of a turn (Note: This is not required for P000-02 ferrule with TPGL hose).

STEP FOUR

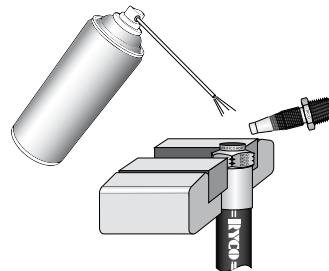

- Lightly lubricate insert and inside of hose.

STEP FIVE

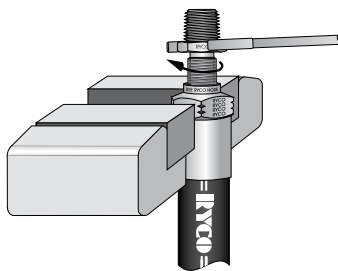

- Screw insert clockwise right into ferrule using a continuous motion.
- Do not allow hose to turn during operation.

SPECIAL NOTES

- **FOR T1D HOSE IN SIZES -20, -24, -32.** In these sizes, K Series Ferrules are not available and A Series Field Attachable Couplings may be used. The cover of hose must be skived at ends. Refer to page 479 for assembly instructions.
- **FOR T2D AND SURVIVOR/2 HOSE IN SIZES -24, -32.** In these sizes, L Series Ferrules are not available and B Series Field Attachable Couplings may be used. The cover of hose must be skived at ends. Refer to page 479 for assembly instructions.
- **FIELD ATTACHABLE COUPLINGS** should not be used at maximum working pressure of hose when temperature exceeds 121°C (250°F). Field Attachable Couplings may be used on suitable hose at over 121°C (250°F) but at reduced working pressure. Contact Ryco Technical Department for more information.

ASSEMBLY INSTRUCTIONS FOR:

Ryco FIELD ATTACHABLE COUPLINGS WITH MATCHED SIZES OF Ryco SKIVE HOSE.
 USE ON LARGER SIZES OF Ryco T1D, T2D and SURVIVOR/2 HOSE, SEE NOTE 1 & 2 on page 478).

STEP ONE



- Cut hose to length required using a cut-off saw.
- Ensure hose is cut squarely.
- Clean hose bore.

STEP TWO

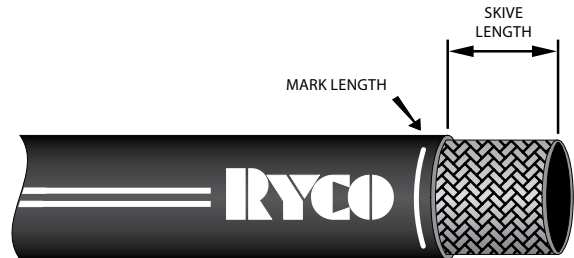

- Mark Skive Length (refer to Hose specification pages).
- Cut rubber cover around and down to wire reinforcement then slit lengthwise.
- Raise flap and pull off with pliers.

STEP THREE

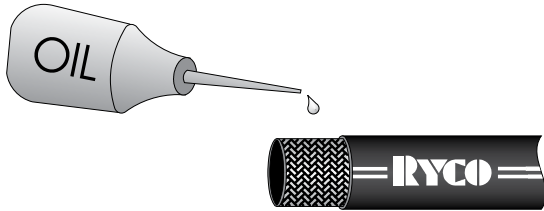

- Lightly lubricate exposed wire reinforcement.

STEP FOUR

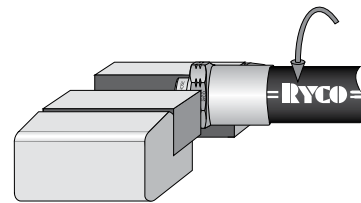

- Screw anti-clockwise until hose bottoms in ferrule.
- Ease back between 1/2 and 3/4 of a turn.

STEP FIVE

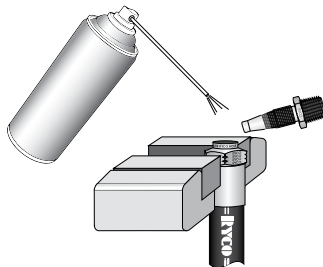

- Lightly lubricate insert and inside of hose.
- **Note: Do not use lubricant for hose to be used with volatile gases.**

STEP SIX

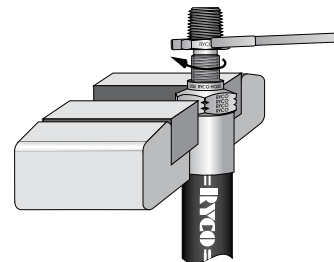

- Screw insert clockwise right into ferrule using a continuous motion.
- Do not allow hose to turn during operation.

ASSEMBLY INSTRUCTIONS FOR:

1. Ryco T2000, T6000 and T7000 SERIES COUPLINGS WITH Ryco NON-SKIVE HOSE.

USE ONLY MATCHED SIZES OF Ryco T3000D, T3000S, T4000D, T4000S, T5000D, T5000S, T6000D, T6000S, H3000D, H3000S, H4000D, H4000S, H5000D, H5000S, H6000D, H6000S, T2C, T1D, T2D, T2J2D, D4000D, TXA2D, T1F, T1S, T2S, BT1, DF2D, D2B, SURVIVOR/1, SURVIVOR/2, H12D, H12S, MS1000, CS1000 (SKIVE), R4SH, TP7, TP7N, TP7T, TP7TN, TP8, TP8N, TP8T and TP8TN SERIES HOSE.

2. Ryco T4000 and TG000 SERIES COUPLINGS WITH Ryco NON-SKIVE HOSE.

USE ONLY MATCHED SIZES OF Ryco, MP1, PL1D, SURVIVOR/R5, TP7, TP7N, TP7T, TP7TN, TP3000, SRX/HT, SRF/P, T5 and TPGL SERIES HOSE. (See page 485 for instructions for separating of ends of TP7T, TP7TN, TP8T and TP8TN Series.)

STEP ONE

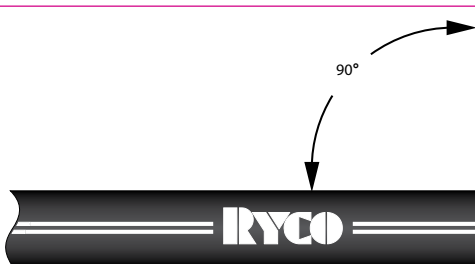

- Cut hose to required length using a cut-off saw.
- Ensure hose is cut squarely.
- Clean hose bore.

STEP TWO

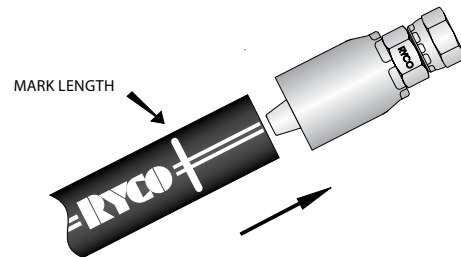

- Mark the Mark Length onto the hose (Mark Length dimension from "Ryco Crimp Chart").
- Push hose into the fitting (lightly lubricate the hose bore only if necessary as excess lubrication may reduce hose assembly impulse life) until the mark on the hose is even with the end of the ferrule*.
- **Note: Push the hose all the way into the fitting.**

STEP THREE

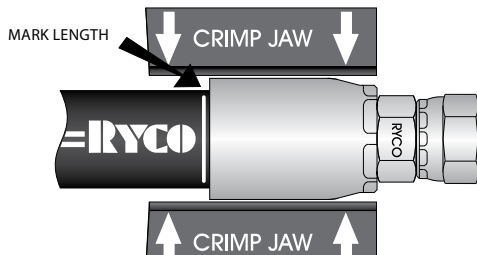

- Place assembled end into the jaws of crimp machine.
- Operate machine to crimp ferrule to predetermined diameter. (Refer to "Ryco Crimp Chart").

STEP FOUR

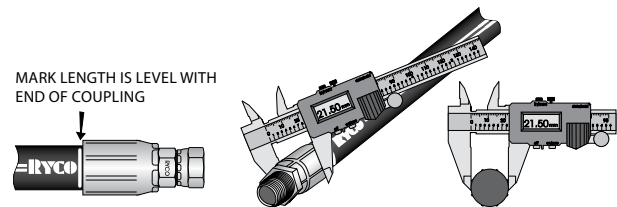

- Open the crimp machine and remove the assembly.
- Check the crimp diameter with a caliper or micrometer. Crimp diameter should be measured halfway along ferrule. Measure between the ridges, and make sure that the caliper fingers do not touch the ridges.
- Check that the Mark Length mark is still visible and even with the end of the ferrule to ensure coupling has not moved during crimping.

NOTES

- **Extra special care must be exercised in the preparation, assembly and crimping of these fittings due to the very high pressures and end loads encountered.**
- **Ryco Crimp Chart detailing Mark or Skive Length and Crimp Diameter is available from Ryco Hydraulics.**

* For TP7, TP7N, TP7T, TP7TN, TP8, TP8N, TP8T, TP8TN, TP3000 and TPGL Hose Series it is preferable to lightly lubricate using a PTFE or Silicon-based aerosol spray lubricant. Use lubricant only if necessary; use sparingly if required.

HOW TO ORDER NON-SKIVE HOSE COUPLINGS

- The Ryco Non-Skive Coupling is a one-piece fitting. Non-Skive Couplings do not require the hose to be skived externally or internally.
- As the Non-Skive Coupling is a complete coupling, simply order by Part Number.

ASSEMBLY INSTRUCTIONS FOR:

Ryco T7000 SERIES COUPLINGS WITH Ryco SKIVE HOSE.
USE ONLY MATCHED SIZES OF Ryco 4SP SERIES HOSE.

STEP ONE

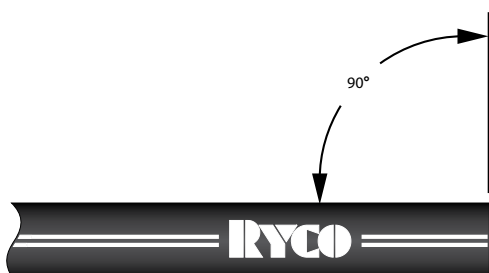

- Cut hose to length required using a cut-off saw.
- Ensure hose is cut squarely.
- Clean hose bore.

STEP TWO

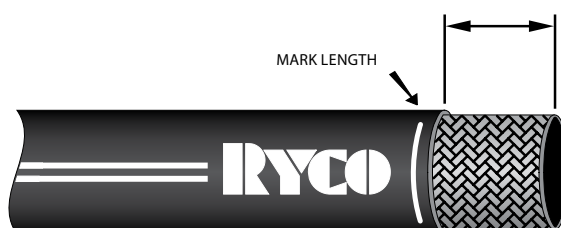

- Mark the Skive Length onto the hose. (Refer to "Ryco Crimp Chart").
- Cut rubber cover around and down to wire reinforcement then slit lengthwise.
- Raise flap and pull off with pliers.
- Measure coupling insertion depth and add a Mark Length Line on the outer cover as shown.

STEP THREE

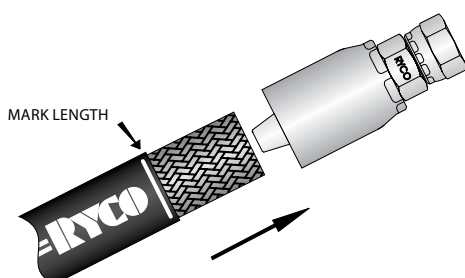

- Push hose into the fitting (lightly lubricate the hose bore only if necessary as excess lubrication may reduce hose assembly impulse life) until the mark on the hose is even with the end of the ferrule.
- **Note: Push the hose all the way into the fitting.**
- **Note: Do not use lubricant for hose to be used with volatile gases.**

STEP FOUR

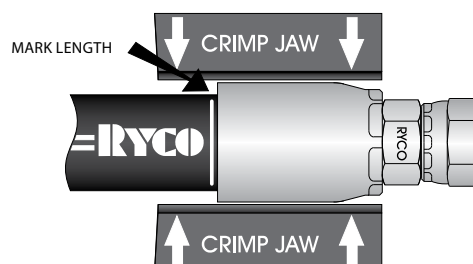

- Place assembled end into jaws of crimp machine.
- Operate machine to crimp ferrule to predetermined diameter. (Refer to "Ryco Crimp Chart").

STEP FIVE

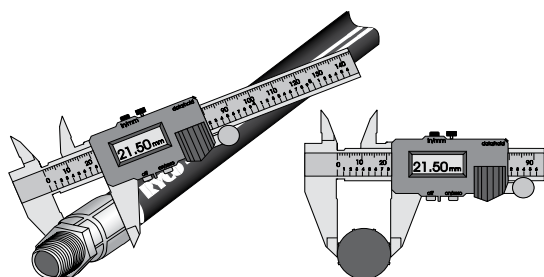

- Open crimp machine and remove assembly.
- Check crimp diameter with caliper or micrometer. Crimp diameter should be measured halfway along the ferrule. Measure between the ridges, and make sure that the caliper fingers do not touch the ridges.
- Check that the ferrule still completely covers the skived part of the hose to ensure coupling has not moved during crimping.

NOTE

- Extra special care must be exercised in the preparation, assembly and crimping of these fittings due to the very high pressures and end loads encountered.
- The latest Ryco Crimp Chart detailing Mark or Skive Length and Crimp Diameter is available from the Ryco website.

ASSEMBLY INSTRUCTIONS FOR:

TT000 SERIES ONE-PIECE COUPLINGS. USE ONLY MATCHED SERIES OF Ryco RTH1 SERIES HOSE.

STEP ONE

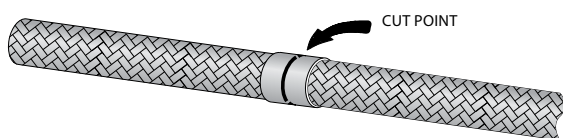

- Tape with masking tape at the cut position to prevent wire braid flaring.

STEP TWO

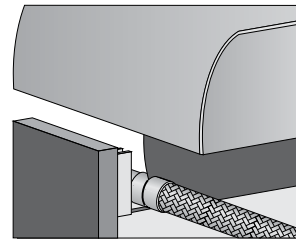

- Cut hose to length. Ensure hose is cut squarely.
- Clean hose bore.
- **WARNING: Do not smoke in the vicinity when cutting RTH1 hoses because fumes created are toxic and may mix with cigarette smoke when inhaled.**

STEP THREE

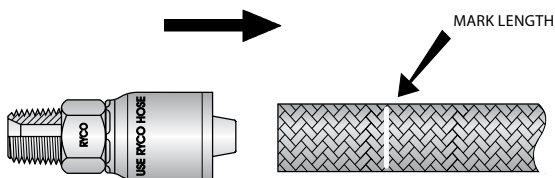

- Refer to "Ryco Crimp Chart" for Mark Length of Coupling.
- Mark outer cover with Mark Length.
- Push hose into the fitting (lightly lubricate the hose bore only if necessary as excess lubrication may reduce hose assembly impulse life) until the mark on the hose is even with the end of the ferrule*.
- **Note: Push the hose all the way into the fitting.**

STEP FOUR

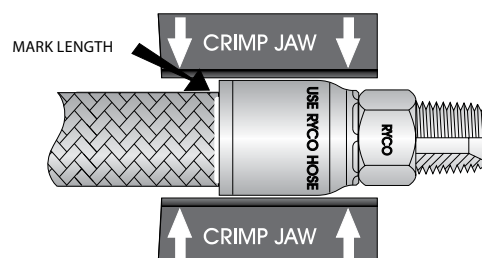

- Place assembled end into the jaws of crimp machine.
- Operate machine to crimp ferrule to predetermined diameter. (Refer to "Ryco Crimp Chart").
- Open the crimp machine.
- Check that the Mark Length mark is still visible and even with the end of the ferrule to ensure coupling has not moved during crimping.

STEP FIVE

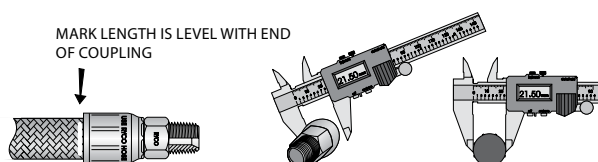

- Check that full length of ferrule has been crimped.
- Check the crimp diameter with a caliper or micrometer. Crimp diameter should be measured halfway along ferrule. Measure between the ridges, and make sure that the caliper fingers do not touch ridges.

NOTE

- **Extra special care must be exercised in the preparation, assembly and crimping of these fittings due to the very high pressures and end loads encountered.**
- **The latest Ryco Crimp Chart detailing Mark or Skive Length and Crimp Diameter is available from the Ryco website.**
- **Note: Do not use lubricant for hose to be used with volatile gases.**

ASSEMBLY INSTRUCTIONS FOR:

33000 SERIES SUCTION HOSE COUPLINGS. Use only MATCHED SERIES OF Ryco SRX/HT and SRF/P SERIES Hose.

STEP ONE

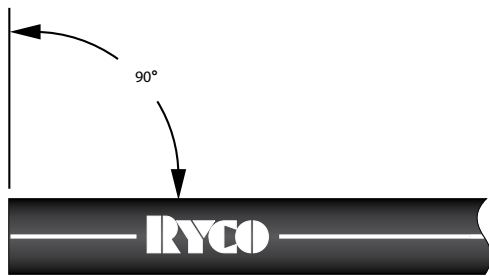

- Cut hose to required length using a cut-off saw.
- Ensure helix wires are not protruding.
- Ensure hose is cut squarely.

STEP TWO

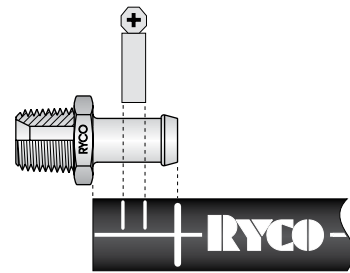

- Mark the cover of the hose to ensure that Clamp will be correctly located.

STEP THREE

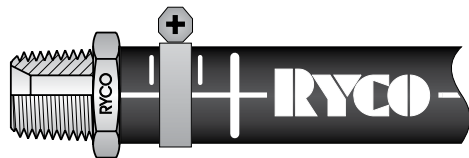

- Slide Clamp over hose.
- Push the coupling into the hose bore until hex or collar abuts end of hose.
- Position Clamp, and tighten bolt to recommended torque.

PUSH-ON HOSE ASSEMBLY

ASSEMBLY INSTRUCTIONS FOR:

8000 SERIES PUSH-ON COUPLINGS. USE ONLY RYCO PL1D, and PL1V.

STEP ONE

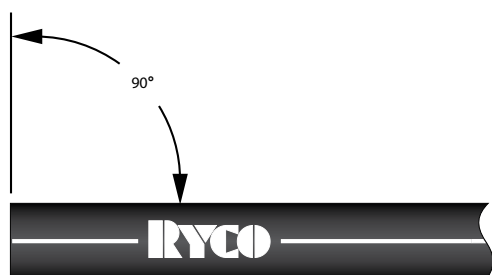

- Cut hose to required length with a sharp knife.
- Lightly lubricate inside of hose and outside of the hose barb.

STEP TWO

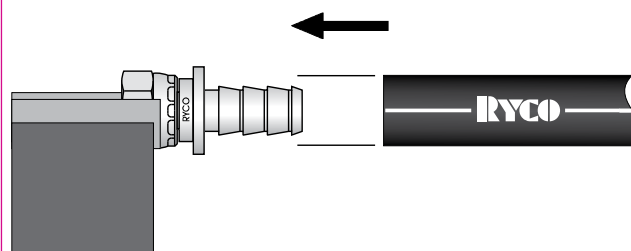

- Push hose onto fitting until hose end bottoms underneath cap as shown.

STEP THREE

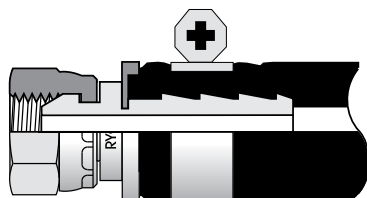

- If hose assembly is to be used at above 50% of Maximum Working Pressure, or in a potentially dangerous or critical application, a clamp must be used.
- Do not overtighten clamp as this may damage hose.

REMOVING COUPLINGS, STEP ONE

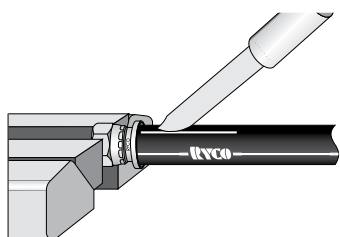

- Remove clamp if fitted.
- Slit hose length-wise, from cap to end of hose tail.

REMOVING COUPLINGS, STEP TWO

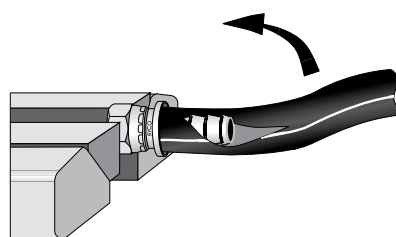

- Sharply bend hose and remove.

ASSEMBLY INSTRUCTIONS - TP7T, TP7TN, TP8T AND TP8TN TWIN HOSE

ASSEMBLY INSTRUCTIONS FOR:

SEPARATION OF THE ENDS OF TP7T, TP7TN, TP8T and TP8TN TWIN HOSE.

Note: Ryco TP7T, TP7TN, TP8T and TP8TN Hose must be separated at the ends to permit the attachment of the couplings. Procedure is as follows.

The latest Ryco Crimp Chart detailing Crimp Diameter and Mark Length is available from the Ryco website.

STEP ONE

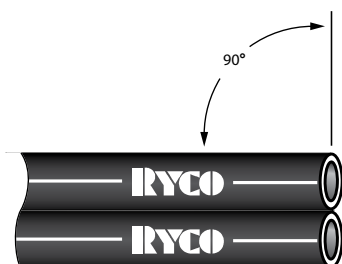

- Cut hose to length required using a sharp knife.
- Ensure hose is cut squarely.
- Clean hose bore.

STEP TWO

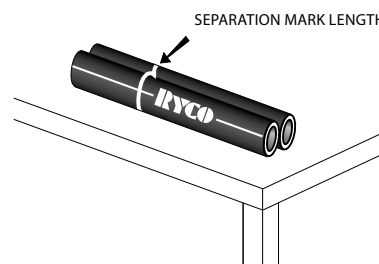

- Arrange the end of the twin line hose so that it is lying straight and flat, resting on the bottom of both hoses, on a horizontal work surface.
- Mark the length to be separated on the cover of the hoses.
- The separation length required may vary depending on the crimper being used.
- Separation length must allow each hose end to be inserted into the crimper without kinking the other hose.

STEP THREE

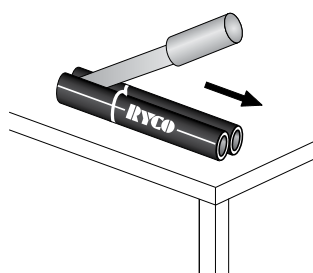

- Hold the hoses flat on the work bench, and lightly score along the joint between the two hoses with a blunt knife.
- Keep the knife vertical to avoid cover damage. It may be necessary to score along the joint several times.
- Take care not to damage the covers of the hoses.
- Turn the hose over and repeat the above to score the other side of the joint.
- The hoses will now be able to be separated by pulling apart.
- Inspect the covers to ensure there is no damage, if the cover is cut or the reinforcement is exposed, the hoses must not be used.

STEP FOUR, FIVE, SIX

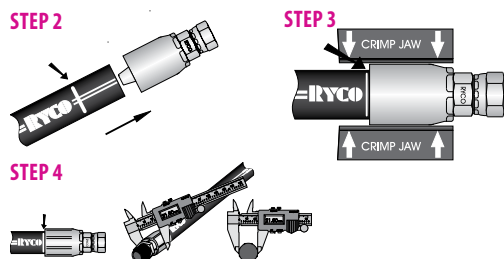

- Follow Step Two, Three and Four of page 491 (Non-Skive Hose Assembly) for each end of the hose.

STEP SEVEN

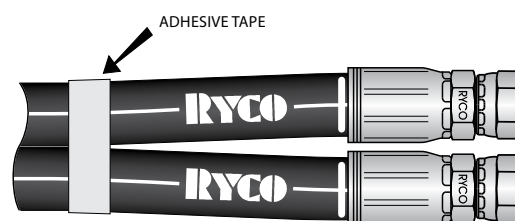

- After crimping the couplings, the hoses can be tied together at the separation area with tape or a cable tie to prevent the hoses becoming further separated accidentally.

TUBE FLARING DIMENSIONS – 37° JIC AND 45° SAE

RYCO S6, S6M, S6S AND SA6 TUBE NUTS AND SLEEVES ARE FOR USE WITH FLARED STEEL HYDRAULIC TUBING.

Dimensions for flares shown below are as specified in SAE J533 "Flares for Tubing".

Tubing must be flared to the correct dimensions. Flares must be free from loose scale, burrs, slivers, and cracks. Seating surfaces must be smooth and free from nicks, pit marks, and any other defects that prevent sealing. The flare seat must be concentric with the tube outside diameter within 0,38 mm (.015") Full Indicator Reading (FIR). Smoothly breaking (radiusing) the outside corner of the tube prior to single flaring, to minimise splitting, is permissible.

For S6, S6S and SA6 for Imperial Outside Diameter Tubing, use only seamless annealed hydraulic tubing to ASTM A179 of wall thickness no greater than that specified in the tables.

For S6M for Metric Outside Diameter Tubing, use only seamless annealed hydraulic tubing of wall thickness no greater than that specified in the tables.

Tubing may be double flared for thin wall thicknesses, or single flared for thicker walled tubing. Dimensions below are for single flared tubing.

Recommended maximum wall thickness of tubing specified in tables is the thickest tubing normally considered suitable for flaring. Optional configurations to provide extended length of seal contact surface for tube wall thickness exceeding the limits in the tables, are also specified in SAE J533.

S6 AND S6S SERIES FOR IMPERIAL OD TUBING WITH JIC 37° FLARE

RYCO S6	RYCO S6S	NOMINAL TUBE OD		MAXIMUM WALL THICKNESS D		MAXIMUM FLARE DIAMETER A		MINIMUM FLARE DIAMETER A		FLARE RADIUS ± 0,25 mm (± 0.01") R	
		mm	inch	mm	inch	mm	inch	mm	inch	mm	inch
PART NO	PART NO										
S6-0502		3,18	0.13	0,89	0.04	5,1	0.20	4,6	0.18	0,80	0.03
S6-0603		4,76	0.19	0,89	0.04	7,1	0.28	6,6	0.26	0,80	0.03
S6-0704		6,35	0.25	1,65	0.06	9,1	0.36	8,6	0.34	0,80	0.03
S6-0805		7,94	0.31	1,65	0.06	10,9	0.43	10,2	0.40	0,80	0.03
S6-0906	S6S-0906	9,52	0.37	1,65	0.06	12,4	0.49	11,7	0.46	1,00	0.04
S6-1208	S6S-1208	12,70	0.50	2,11	0.08	16,8	0.66	16,0	0.63	1,50	0.06
S6-1410	S6S-1410	15,88	0.63	2,41	0.09	20,1	0.79	19,3	0.76	1,50	0.06
S6-1712		19,05	0.75	2,77	0.11	24,1	0.95	23,4	0.92	2,00	0.08
S6-1914		22,22	0.87	2,77	0.11	27,2	1.07	26,4	1.04	2,00	0.08
S6-2116		25,40	1.00	3,05	0.12	30,5	1.20	29,7	1.17	2,30	0.09
S6-2620		31,75	1.25	3,05	0.12	38,4	1.51	37,6	1.48	2,30	0.09
S6-3024		38,1	1.50	3,05	0.12	43,9	1.73	43,2	1.70	2,80	0.11
S6-4032		50,8	2.00	3,40	0.13	59,9	2.36	59,2	2.33	2,80	0.11

TUBE FLARING DIMENSIONS – 37° JIC AND 45° SAE

S6M SERIES FOR METRIC OD TUBING WITH JIC 37° FLARE

RYCO S6M	NOMINAL TUBE OD		MAXIMUM WALL THICKNESS D		MAXIMUM FLARE DIAMETER A		MINIMUM FLARE DIAMETER A		FLARE RADIUS ± 0,25 mm (± 0.01") R	
	mm	inch	mm	inch	mm	inch	mm	inch	mm	inch
S6M-0503	3,00	0.12	0,89	0.04	5,1	0.20	4,6	0.18	0,80	0.03
S6M-0605	5,00	0.20	0,89	0.04	7,1	0.28	6,6	0.26	0,80	0.03
S6M-0706	6,00	0.24	1,65	0.06	9,1	0.36	8,6	0.34	0,80	0.03
S6M-0808	8,00	0.31	1,65	0.06	10,9	0.43	10,2	0.40	0,80	0.03
S6M-0910	10,00	0.39	1,65	0.06	12,4	0.49	11,7	0.46	1,00	0.04
S6M-1212	12,00	0.47	2,11	0.08	16,8	0.66	16,0	0.63	1,50	0.06
S6M-1416	16,00	0.63	2,41	0.09	20,1	0.79	19,3	0.76	1,50	0.06
S6M-1719	19,00	0.75	2,77	0.11	24,1	0.95	23,4	0.92	2,00	0.08
S6M-1920	20,00	0.79	2,77	0.11	27,2	1.07	26,4	1.04	2,00	0.08
S6M-2125	25,00	0.98	3,05	0.12	30,5	1.20	29,7	1.17	2,30	0.09
S6M-2632	32,00	1.26	3,05	0.12	38,4	1.51	37,6	1.48	2,30	0.09
S6M-3038	38,00	1.50	3,05	0.12	43,9	1.73	43,2	1.70	2,80	0.11
S6M-4051	51,00	2.01	3,40	0.13	59,9	2.36	59,2	2.33	2,80	0.11

SA6 SERIES FOR IMPERIAL OD TUBING WITH SAE 45° FLARE

RYCO SA6	NOMINAL TUBE OD		MAXIMUM WALL THICKNESS D		MAXIMUM FLARE DIAMETER A		MINIMUM FLARE DIAMETER A		FLARE RADIUS ± 0,25 mm (± 0.01") R	
	mm	inch	mm	inch	mm	inch	mm	inch	mm	inch
SA6-1006	9,52	0.38	1,65	0.06	12,4	0.49	12,0	0.47	0,50	0.02
SA6-1712	19,05	0.75	2,77	0.11	23,3	0.92	22,9	0.90	0,50	0.02

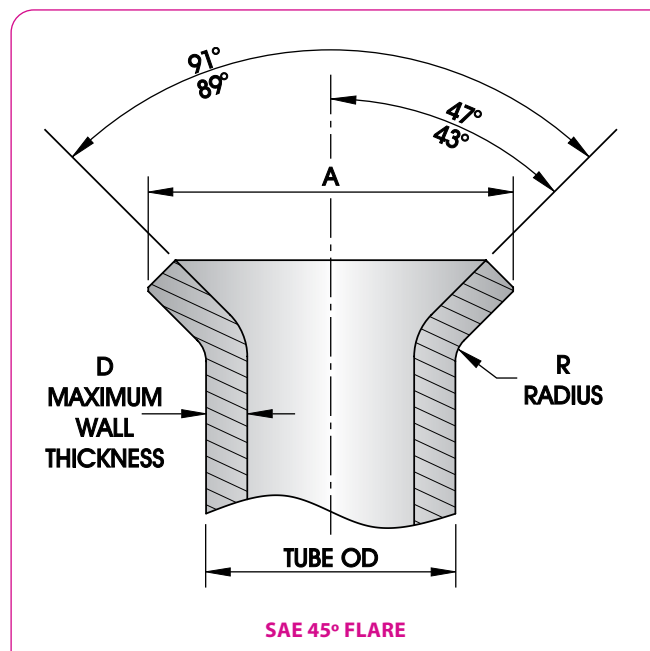
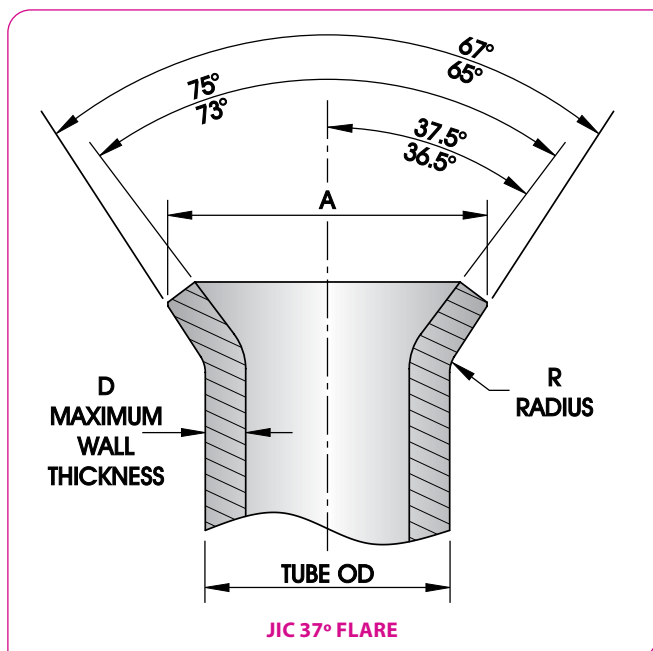

INTRODUCTION

HOSES

TECHNICAL

ASSEMBLY INSTRUCTIONS FOR:

TUBE BITE HOSE COUPLINGS (END STYLE 850).

Ryco Hose Couplings Series with Tube Bite End Style 850 (T2850, T4850 and 6850 Series) provide a quick and convenient method of connecting Imperial Outside Diameter seamless steel hydraulic tubing, without the need to flare the tubing.

They allow quick and economical repairs to assemblies made of combined hose and Imperial-sized tubing. Often in these assemblies, the tubing is bent to a special shape or includes special mounting brackets, and is difficult or expensive to replace.

STEP ONE

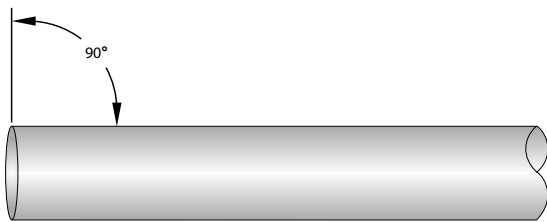

- Ensure that the wall thickness of the tubing is of the approved gauge. See S134 J-Lok & Tubing Selection Table page 491.
- Cut the tube to required length. Ensure that the tube is cut squarely. A tube cutter is preferred, however a hacksaw or abrasive drop saw may be used providing the cut is square and clean.
- Deburr inner and outer edges of tube.

STEP TWO

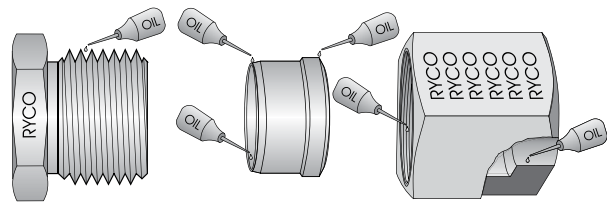

- Remove dirt, grit and cutting debris from the inside and outside of the tube.
- Remove the Nut and Compression Olive from the T2850, T4850 or 6850 coupling.
- Lubricate the threads of the Nut and the Male Thread of the T2850, T4850 or 6850 coupling with assembly oil or hydraulic oil.
- Lubricate internal and external surfaces of the Compression Olive with assembly oil or hydraulic oil.

STEP THREE

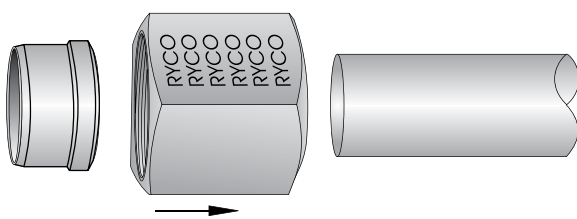

- Slide the Nut onto the tube, so that the threads of the Nut face towards the end of the tube to be assembled to the coupling, then slide the Compression Olive onto the tube.
- The end with the raised collar must be adjacent to the Nut, and the end with the long parallel section must face towards the end of the tube to be assembled to the coupling.

STEP FOUR

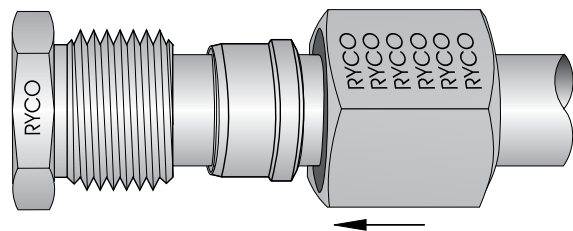

- Insert the tube end into the Male Threaded end of the T2850, T4850 or 6850 coupling, until it bottoms against the shoulder inside the Male Threaded end.
- Slide the Nut and Compression Olive along the tube until the Compression Olive seats inside the coupling body, and thread the Nut onto the Male Threaded end of the coupling.
- Tighten Nut until the Compression Olive just grips the tube. The initial gripping of the tube is complete when the tube can no longer be rotated by hand.

STEP FIVE

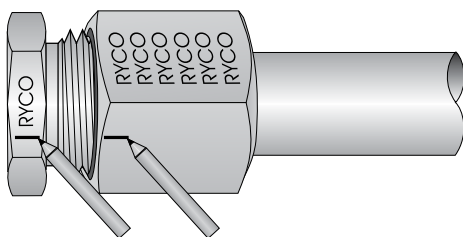

- Place a mark on the Nut, and an adjacent mark on the Hex of the T2850, T4850 or 6850 coupling insert.

STEP SIX

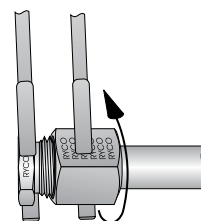

- Holding the hex of the T2850, T4850 or 6850 coupling insert stationary with one spanner, with another spanner tighten the Nut down by one full turn, to compress the Olive onto the tube¹.
- Use the marks from Step 5 as a reference. Ensure that the tube end is firmly butted against the shoulder inside the coupling, and that the tube does not rotate².

ASSEMBLY INSTRUCTIONS – TUBE BITE HOSE COUPLINGS (END STYLE 850)

ASSEMBLY INSTRUCTIONS FOR:

TUBE BITE HOSE COUPLINGS (END STYLE 850) CONT.

If safe to do so, the bent tube part can be cut from the old assembly and reused. (NOTE: for combined hose and tubing assemblies with Metric Tubing, Male DKL or DKS Hose Coupling can be used with M6L or M6S Metric Nut and Cutting Ring).

INTRODUCTION

HOSES

TECHNICAL

STEP SEVEN

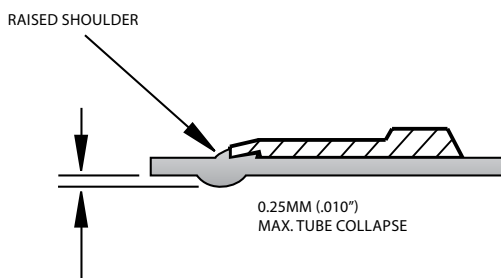

- Disassemble the Nut from the Coupling.
- Inspect the front edge of the Compression Olive. For correct assembly, the cutting edge of the Compression Olive must have formed a shoulder on the tube at least 50% as high as the cutting edge, all the way around the tube³.

STEP EIGHT

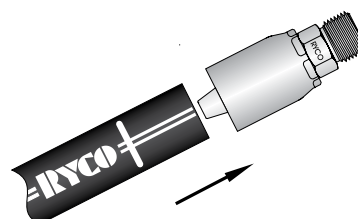

- Attach the T2850, T4850 or 6850 coupling onto the hose, without the tube, Nut and Compression Olive connected to it.
- Refer to the appropriate Assembly Instructions for the Hose Series and Coupling Series being assembled.
- Do not assemble the coupling onto the hose until Steps One to Seven are completed.

STEP NINE

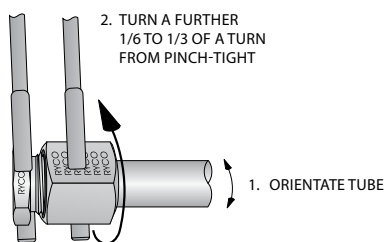

- Re-assemble the tube, Nut and Compression Olive onto the T2850, T4850 or 6850 end of the hose assembly.
- Nut will turn easily until an increase in force is required. At this point, orient the bent tube assembly pointing to the correct direction if required.
- Holding the Hex of the T285, T485 or 685 coupling insert with one spanner, with another spanner tighten the Nut down a further 1/6 of a turn as a minimum, but no more than 1/3 of a turn, to complete tightening operation.

NOTES

- 1 This is a general rule, and may vary slightly with different tubing materials.
- 2 In some instances (especially when using soft or thin-walled tube), to prevent excessive tube collapse, it may be necessary to support the inside of the tube with a mandrel prior to setting the Compression Olive.
- 3 Note that the maximum allowable radial collapse of the inner tube diameter is 0,25 mm (.010").

ASSEMBLY INSTRUCTIONS FOR:

S134 Series J-Lok Flareless Tube Fittings.

Ryco S134 J-Lok Flareless Tube Fittings provide a quick and convenient method of connecting Imperial Outside Diameter seamless steel hydraulic tubing to Ryco JIC male threads with 37° seat, without the need to flare the tubing. The wall thickness of the tubing must be of the approved gauge (see page 491 for Selection Table).

STEP ONE



- Ensure that the wall thickness of the tubing is of the approved gauge. See S134 J-Lok & Tubing Selection Table on page 491.
- Cut the tube to required length. Ensure that the tube is cut squarely. A tube cutter is preferred, however a hacksaw or abrasive drop saw may be used providing the cut is square and clean.
- Deburr inner and outer edges of tube.

STEP TWO

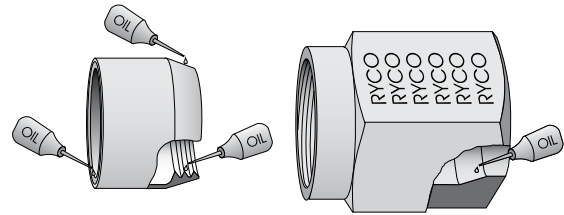

- Remove dirt, grit and cutting debris from the inside and outside of the tube.
- Lubricate the mating surfaces of the S134 J-Lok Flareless Olive and Nut with assembly oil or hydraulic oil.
- Ensure that the teeth inside the Flareless Olive are well lubricated.

STEP THREE

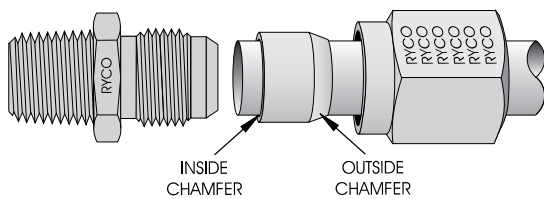

- Slide the S134 Nut on to the tube, so that the thread of the Nut faces towards the end of the tube.
- Then slide the S134 Flareless Olive onto the tube. The outside chamfered end must be adjacent to the S134 Nut, and the inside chamfered end must face towards the end of the tube.

STEP FOUR

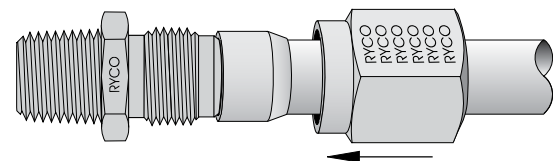

- Butt the tube end against the JIC male seat.
- With the tube held against the JIC male seat, slide the S134 Nut and Flareless Olive along the tube, until the Flareless Olive mates with the JIC male seat, and the S134 Nut mates with the JIC male thread.

STEP FIVE

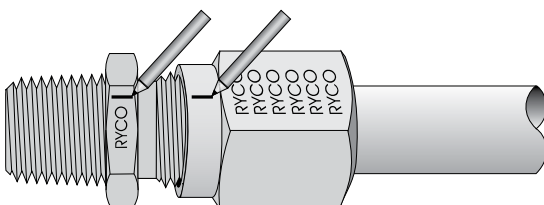

- Engage the thread of the S134 Nut with the mating JIC male thread, while holding the tube against the JIC male seat. Prevent the tube from rotating.
- When the S134 Nut cannot be further tightened by hand onto the JIC male thread, place a mark on collar of the S134 Nut, and an adjacent mark on the JIC male hex.

STEP SIX

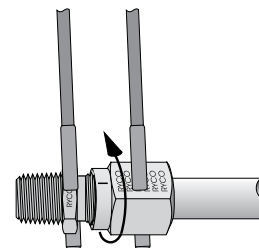

- Hold the JIC male hex stationary and further tighten the S134 Nut by spanner, rotating it 1¼ turns.
- Use the marks from STEP 5 as a reference.
- Ensure the tube is always held against the JIC male seat and prevent the tube from rotating.

ASSEMBLY INSTRUCTIONS - S134 J-LOK FLARELESS TUBE FITTINGS

ASSEMBLY INSTRUCTIONS FOR:

S134 Series J-Lok Flareless Tube Fittings. Cont.

Ryco S134 J-Lok Flareless Tube Fittings provide a quick and convenient method of connecting Imperial Outside Diameter seamless steel hydraulic tubing to Ryco JIC male threads with 37° seat, without the need to flare the tubing. The wall thickness of the tubing must be of the approved gauge (see below for Selection Table).

INTRODUCTION

STEP SEVEN

- **If the connection is to be undone and then reassembled:**
- First tighten the S134 Nut onto the JIC male thread by hand.
- When the S134 Nut cannot be further hand tightened, tighten it with a spanner one more hex flat (1/6 of a turn).
- Ryco S134 J-Loks may be reassembled in this manner approximately ten times.

HOSES

TECHNICAL

SELECTION TABLE FOR S134 J-LOK FITTINGS AND TUBING

TUBING USED MUST BE IMPERIAL OUTSIDE DIAMETER SEAMLESS ANNEALED STEEL HYDRAULIC TUBING TO ASTM A179.

RYCO S134 J-LOK	TUBE OD X GAUGE	TUBE DIMENSIONS (INCH)			TUBE DIMENSIONS (MM)			MAXIMUM DYNAMIC WORKING PRESSURE	
		OUTSIDE DIAMETER	WALL THICKNESS	INSIDE DIAMETER	OUTSIDE DIAMETER	WALL THICKNESS	INSIDE DIAMETER	bar	psi
PART NO		inch	inch	inch	mm	mm	mm	bar	psi
S134-0704	1/4 x 20G	0.250	0.035	0.180	6,35	0,91	4,53	238	3450
S134-0906	3/8 x 18G	0.375	0.049	0.277	9,53	1,22	7,09	252	3650
S134-0906	3/8 x 16G	0.375	0.065	0.245	9,53	1,63	6,27	310	4500
S134-1208	1/2 x 18G	0.500	0.049	0.402	12,70	1,22	10,26	183	2650
S134-1208	1/2 x 16G	0.500	0.065	0.370	12,70	1,63	9,44	252	3650
S134-1410	5/8 x 16G	0.625	0.065	0.495	15,88	1,63	12,62	197	2850
S134-1410	5/8 x 14G	0.625	0.080	0.465	15,88	2,03	11,82	207	3000
S134-1712	3/4 x 16G	0.750	0.065	0.620	19,05	1,63	15,79	162	2350
S134-1712	3/4 x 14G	0.750	0.080	0.590	19,05	2,03	14,99	207	3000
S134-2116	1 x 14G	1.000	0.080	0.840	25,40	2,03	21,34	152	2200
S134-2116	1 x 12G	1.000	0.104	0.792	25,40	2,64	20,12	193	2800

INSTALLATION GUIDE - HOSE ASSEMBLY

Proper hose installation is essential for satisfactory performance. If hose length is excessive, the appearance of the installation will be unsatisfactory and unnecessary cost of equipment will be involved. If hose assemblies are too short to permit adequate flexing and changes in length due to expansion or contraction, hose service life will be reduced.

The following diagrams show proper hose installations which provide maximum performance and cost savings. Consider these examples in determining length of a specific assembly.

STRAIGHT HOSE INSTALLATIONS

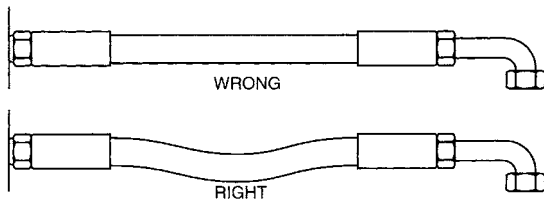

- When hose installation is straight, allow enough slack in hose line to provide for length changes that will occur when pressure is applied.

FLEXING APPLICATIONS

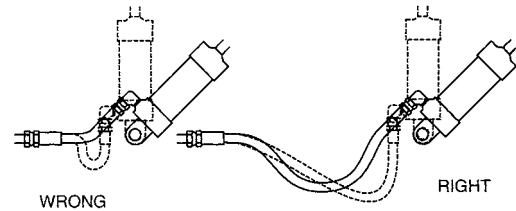

- Adequate hose length is necessary to distribute movement on flexing applications, and to avoid abrasion.

TWISTS AND BENDS, PART ONE

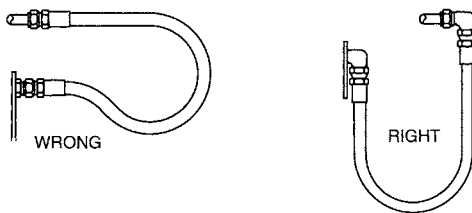

- When radius is below the required minimum, use an angle adaptor to avoid sharp bends.

TWISTS AND BENDS, PART TWO

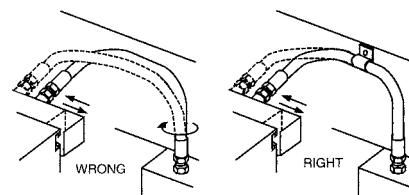

- Avoid twisting of hose lines bent in two planes by clamping hose at change of plane.

TWISTS AND BENDS, PART THREE

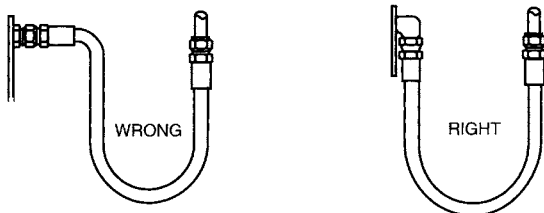

- Use proper angle adaptors to avoid sharp twists or bends in the hose.

TWISTS AND BENDS, PART FOUR

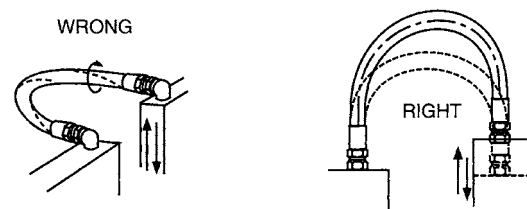

- Prevent twisting and distortion by bending hose in same plane as the motion of the boss to which hose is connected.

INSTALLATION GUIDE - HOSE ASSEMBLY (CONT)

Proper hose installation is essential for satisfactory performance. If hose length is excessive, the appearance of the installation will be unsatisfactory and unnecessary cost of equipment will be involved. If hose assemblies are too short to permit adequate flexing and changes in length due to expansion or contraction, hose service life will be reduced.

The following diagrams show proper hose installations which provide maximum performance and cost savings. Consider these examples in determining length of a specific assembly.

REDUCE NUMBER OF PIPE FITTINGS

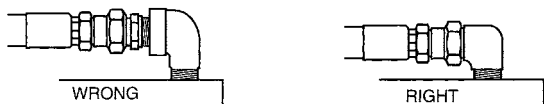

- Reduce number of pipe thread joints by using proper hydraulic adaptors instead of pipe fittings.

USE 45° AND/OR 90° ADAPTORS

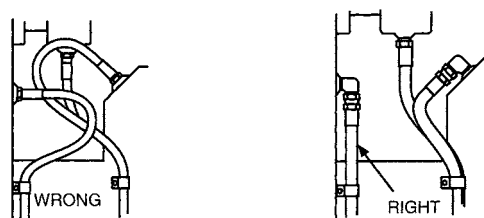

- Route hose directly by using 45° and/or 90° adaptors and fittings.
- Avoid excessive hose length to improve appearance.

ALLOWING FOR LENGTH CHANGE

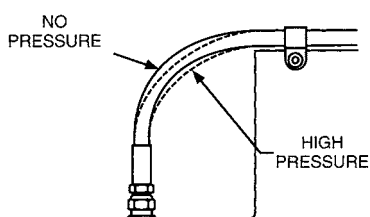

- To allow for length changes when hose is pressurised, do not clamp at bends.
- Curves will absorb changes.
- Do not clamp high and low pressure lines together.

AVOID TWISTING HOSE

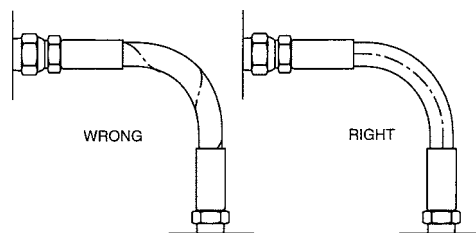

- When installing hose, make sure it is not twisted.
- Pressure applied to a twisted hose can result in hose failure or loosening of connections.

HIGH TEMPERATURE

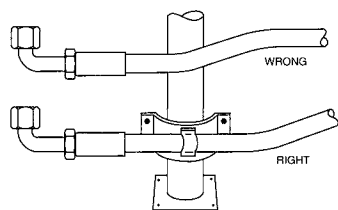

- High ambient temperatures shorten hose, therefore ensure hose is kept away from hot parts.
- If this is not possible, insulate hose.

RELIEVE STRAIN

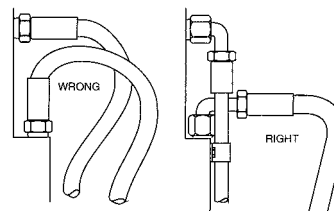

- Elbows and adaptors should be used to relieve strain on the assembly, and to provide neater installations which will be more accessible for inspection and maintenance.

INSTALLATION GUIDE - HOSE ASSEMBLY (CONT)

Proper hose installation is essential for satisfactory performance. If hose length is excessive, the appearance of the installation will be unsatisfactory and unnecessary cost of equipment will be involved. If hose assemblies are too short to permit adequate flexing and changes in length due to expansion or contraction, hose service life will be reduced.

The following diagrams show proper hose installations which provide maximum performance and cost savings. Consider these examples in determining length of a specific assembly.

AVOID COLLAPSE AND RESTRICTION

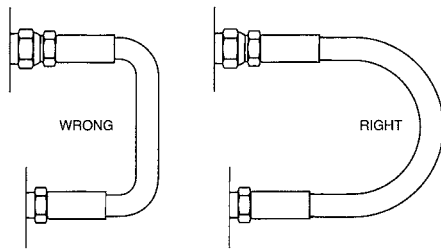

- To avoid hose collapse and flow restriction, keep hose bend radii as large as possible.
- Refer to hose specification tables for minimum bend radii.

AVOID ABRASION

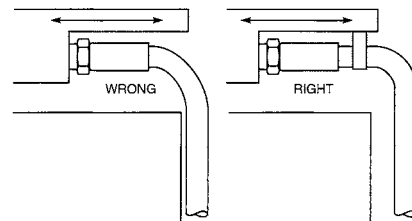

- Run hose in the installation so that it avoids rubbing and abrasion.
- Often, clamps are required to support long hose runs or to keep hose away from moving parts.
- Use clamps of the correct size. A clamp too large allows hose to move inside the clamp and causes abrasion.

NOTE

- When determining the length of hose assemblies, provide sufficient length to prevent bending strain from localising at the back of the coupling. In the 'TYPICAL DIMENSIONS FOR ONE & TWO WIRE BRAID HOSE' diagram below, measurement "B" allows for a strain section of hose beyond the coupling to prevent concentration of bending strain. "T" designates the amount of travel. "A" indicates the smallest diameter to which hose should be bent.
- **OVERALL LENGTH = B+1.57A+T**

TYPICAL DIMENSIONS FOR ONE & TWO WIRE BRAID HOSE

HOSE SIZE			"B" CONSTANT FOR STRAIGHT PORTION INCLUDING COUPLING
DN	inch	Dash	
6	1/4	-04	250 mm (10")
10	3/8	-06	250 mm (10")
12	1/2	-08	300 mm (12)
19	3/4	-12	350 mm (14")
25	1	-16	400 mm (16")
31	1.1/4	-20	450 mm (28")
38	1.1/2	-24	500 mm (20")
51	2	-32	500 mm (20")

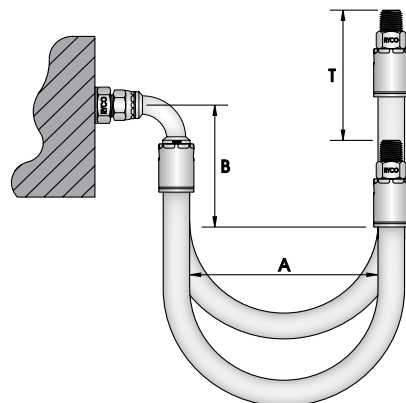

FACTOR OF SAFETY (FOS)

Hydraulic Hose Assemblies have a rated maximum working pressure (MWP) of the lesser of the MWP of the hydraulic hose and the MWP of the connector terminations.

Hydraulic Hose has a finite life. The lifespan of Hydraulic Hose Assemblies is affected by many factors (see 'Hose Selection' and 'Safety Guide' pages 467 to 474, and Ryco HALP® program page 23). Three limiting factors are working pressure, temperature and impulse pressures (pulses). High Impulse Pressures will fatigue hydraulic hose and consume their life.

Fatigue life is specified by a logarithmic **P-N Curve**, where **P** = Pressure and **N** = Impulses.

Hydraulic hose assemblies require a FOS (Factor of Safety) of 4:1.

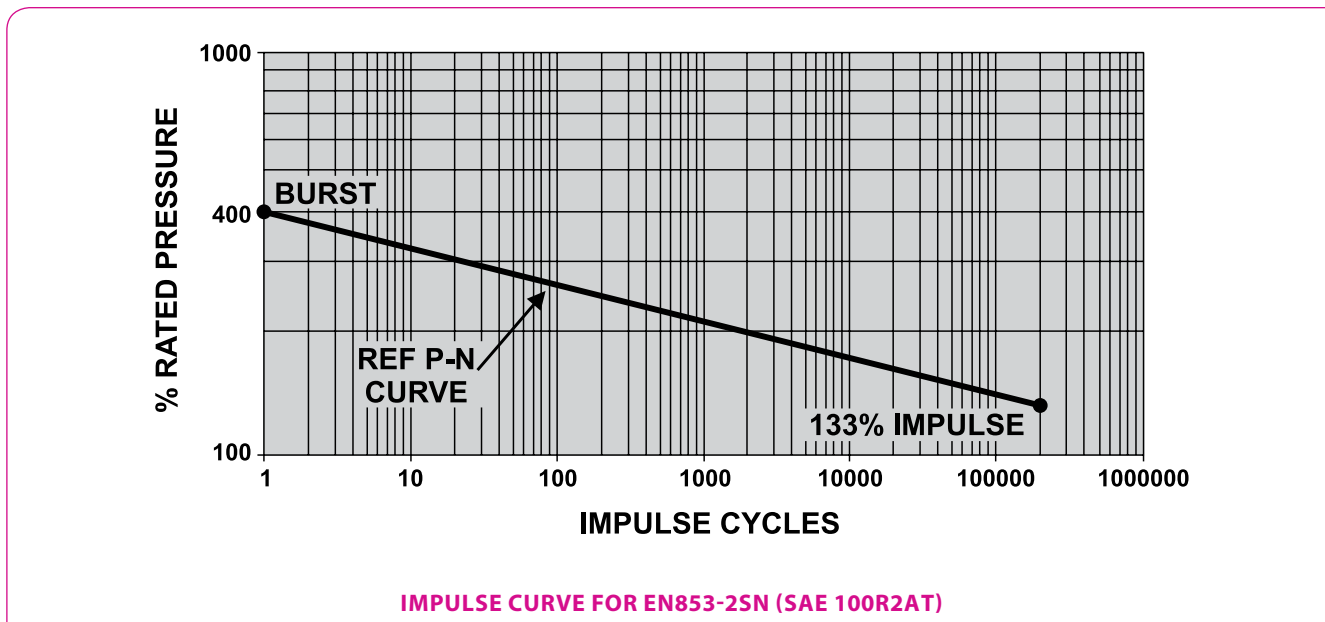

This implies that an unused hydraulic hose assembly has to be able reach four times its MWP (4 x MWP) once only (one pulse). Depending upon the specification requirements of the hydraulic hose, the Hydraulic Hose Assembly (be sure to use couplings that are MATCHED to the hose) must pass an Impulse Test (fatigue life test) at a specified percentage of the hose MWP for a specified number of pressure impulses. In the example above we see that EN853-2SN requires 200,000 impulses at 133% of its MWP (rated pressure). Impulse Tests are generally conducted with fluid heated to the maximum rated operating temperature of the hose.

Ryco Hydraulics Connector Terminations have a FOS of 4:1.

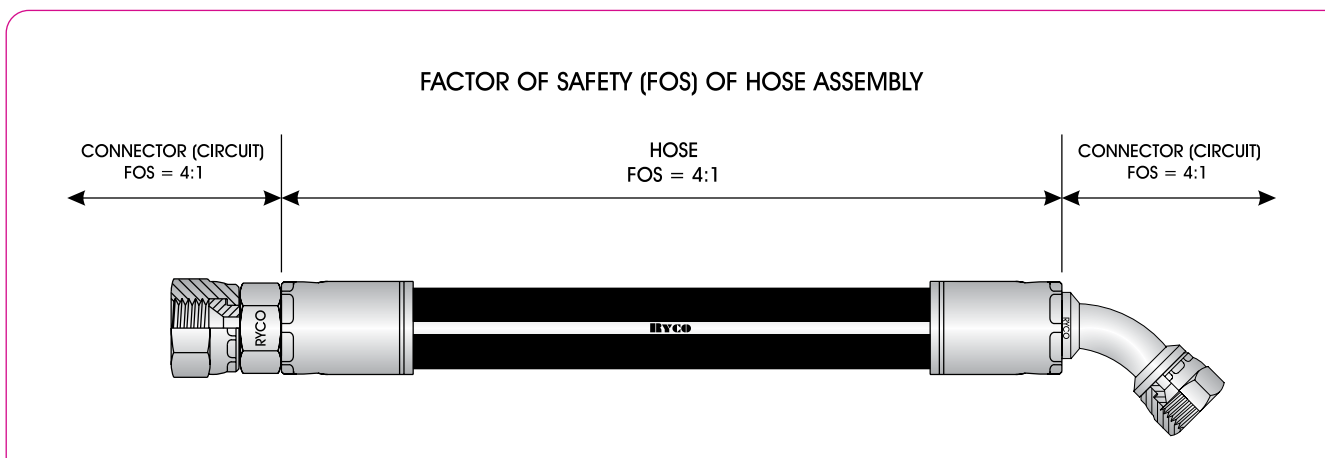

TECHNICAL

GUIDE TO THREAD AND CONNECTOR WORKING PRESSURES

WORKING PRESSURES - ADAPTORS, HOSE COUPLINGS AND HOSE ASSEMBLIES.

Since many factors influence the pressure at which a hydraulic system will, or will not, perform satisfactorily, maximum working pressures listed below should be used as a guide only and not as a "standard" nor "specification", nor construed as a "guaranteed minimum." Within the fluid power industry, many criteria are used for the determination of pressure capability. Various fibre stresses, minimum yields and design factors are applied, commensurate with total system conditions. Thus, it is impractical to lay down specific allowable working pressures that satisfy all design criteria. Unless otherwise specified in this document, and given correct working conditions, including, but not limited to, torque setting, assembly, alignment, support, pressures (internal and external), temperature limits, environmental, installation, vibration free, damage free, chemical, cleanliness and regular maintenance and inspection, the following may be used as a guide to maximum working pressure. For further technical assistance contact Ryco Hydraulics Technical Department or your Ryco Hydraulics distributor.

The Maximum Working Pressure of a Hose Assembly is the lesser rated Working Pressure of the Hose or Tube or End Style (Connector termination). The Maximum Rated Working Pressure of an Adaptor with a combination of Thread / End Styles and sizes, is the Maximum Working Pressure of the least rated end.

BSP	BSPT MALE	BSPP MALE	BSPT MALE LIVE SWIVEL	BSPT FEMALE FIXED	BSPP FEMALE SWIVEL (CRIMP NUT)	BSPP FEMALE SWIVEL (WIRE NUT)	BSPO FEMALE SWIVEL	BSPP MALE NON-ADJUSTABLE (O RING & RETAINING RING)
-----	-----------	-----------	-----------------------	-------------------	--------------------------------	-------------------------------	--------------------	--



THREAD SIZE	DASH SIZE	MAX. WORKING PRESSURE															
		bar	psi	bar	psi	bar	psi	bar	psi	bar	psi	bar	psi	bar	psi	bar	psi
1/8	-02	690	10000	690	10000	420	6100	690	10000	690	10000			690	10000	350	5100
1/4	-04	690	10000	690	10000	420	6100	690	10000	690	10000			690	10000	350	5100
3/8	-06	690	10000	620	9000	420	6100	690	10000	620	9000			620	9000	350	5100
1/2	-08	690	10000	480	7000	350	5100	690	10000	480	7000			480	7000	350	5100
5/8	-10	690	10000	480	7000	280	4100	690	10000	480	7000	550	8000	480	7000	350	5100
3/4	-12	620	9000	450	6500	280	4100	620	9000	420	6100	420	6100	420	6100	280	4100
1	-16	620	9000	350	5100	215	3100	620	9000	350	5100	350	5100	350	5100	215	3100
1.1/4	-20	480	7000	215	3100			480	7000	215	3100	215	3100	215	3100	215	3100
1.1/2	-24	420	6100	100	1500			420	6100			100	1500	100	1500	215	3100
2	-32	350	5100	100	1500			350	5100			100	1500	100	1500	180	2600
2.1/2	-40	215	3100														

BSP	BSPP MALE ADJUSTABLE (O RING & RETAINING RING)	BSPP MALE (BONDED SEAL)	BSPP MALE (ENCAPSULATED SEAL)
-----	--	-------------------------	-------------------------------



THREAD SIZE	DASH SIZE	MAX. WORKING PRESSURE					
		bar	psi	bar	psi	bar	psi
1/8	-02	380	5500	420	6100	620	9000
1/4	-04	350	5100	420	6100	620	9000
3/8	-06	350	5100	420	6100	480	7000
1/2	-08	310	4500	350	5100	480	7000
5/8	-10			350	5100	480	7000
3/4	-12	280	4100	280	4100	480	7000
1	-16	215	3100	280	4100	370	5300
1.1/4	-20	170	2500	280	4100	280	4100
1.1/2	-24			215	3100	280	4100
2	-32			150	2100	230	3300

GUIDE TO THREAD AND CONNECTOR WORKING PRESSURES

NPT	NPT MALE	NPT MALE LIVE SWIVEL	NPT FEMALE FIXED	NPSM FEMALE SWIVEL (CRIMP NUT)	NPSM FEMALE SWIVEL (WIRE NUT)
-----	----------	----------------------	------------------	--------------------------------	-------------------------------

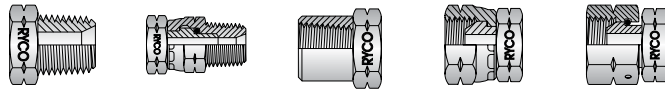

JSEAL™	JSEAL™ FEMALE CONCAVE SEAT
--------	----------------------------



THREAD SIZE	DASH SIZE	MAX. WORKING PRESSURE									
		bar	psi	bar	psi	bar	psi	bar	psi	bar	psi
1/8	-02	760	11000	420	6100	760	11000	690	10000		
1/4	-04	760	11000	420	6100	760	11000	690	10000		
3/8	-06	690	10000	420	6100	690	10000	690	10000		
1/2	-08	690	10000	350	5100	690	10000	550	8000		
5/8	-10										
3/4	-12	690	10000	280	4100	690	10000	450	6500	480	7000
1	-16	500	7200	280	4100	500	7200	350	5100	420	6100
1.1/4	-20	350	5100			350	5100	280	4100	420	6100
1.1/2	-24	350	5100			350	5100	280	4100	280	4100
2	-32	350	5100			350	5100	215	3100	215	3100
2.1/2	-40	215	3100							215	3100

THREAD SIZE	DASH SIZE	MAX. WORKING PRESSURE	
		bar	psi
7/16	-07	700	10100
1/2	-08	700	10100
9/16	-09	700	10100
3/4	-12	630	9100
7/8	-14	630	9100
1.1/16	-17	560	8100
1.3/16	-19	490	7100
1.5/16	-21	420	6100
1.5/8	-26	420	6100
1.7/8	-30	350	5100
2.1/2	-40	280	4100

JIS	METRIC FEMALE SWIVEL 60° CONCAVE SEAT
-----	---------------------------------------



THREAD SIZE	DASH SIZE	MAX. WORKING PRESSURE	
mm		bar	psi
M14 x 1,5	-14	420	6100
M16 x 1,5	-16	420	6100
M18 x 1,5	-18	420	6100
M22 x 1,5	-22	380	5500
M24 x 1,5	-24	350	5100
M27 x 2,0	-27	280	4100
M30 x 1,5	-30	280	4100
M33 x 1,5	-33	215	3100
M33 x 2,0	-33	215	3100
M36 x 1,5	-36	170	2500
M42 x 1,5	-42	170	2500
M50 x 2,0	-50	100	1500
M60 x 2,0	-60	70	1000

JIC	JIC MALE	JIC FEMALE SWIVEL (CRIMP NUT)	JIC FEMALE SWIVEL (WIRE NUT)	JIC FEMALE SWIVEL HIGH PRESSURE ("V" SERIES)
-----	----------	-------------------------------	------------------------------	--

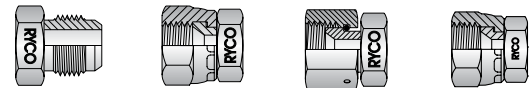

TUBE SIZE	THREAD SIZE	DASH SIZE	MAX. WORKING PRESSURE							
			bar	psi	bar	psi	bar	psi	bar	psi
3/16	3/8	-06	690	10000	690	10000				
1/4	7/16	-07	690	10000	690	10000				
5/16	1/2	-08	620	9000	620	9000				
3/8	9/16	-09	550	8000	550	8000				
1/2	3/4	-12	690	10000	690	10000				
5/8	7/8	-14	550	8000	550	8000	590	8500		
3/4	1.1/16	-17	480	7000	480	7000	550	8000		
7/8	1.3/16	-19	420	6100	380	5500	420	6100		
1	1.5/16	-21	420	6100	320	4600	240	3500	350	5100
1.1/4	1.5/8	-26	350	5100	215	3100	240	3500	350	5100
1.1/2	1.7/8	-30	215	3100			215	3100	350	5100
2	2.1/2	-40	150	2100			110	1600		
2.1/2	3	-48								

INTRODUCTION

HOSES

TECHNICAL

TECHNICAL

GUIDE TO THREAD AND CONNECTOR WORKING PRESSURES

JIS	BSPP MALE	BSPP FEMALE
	60° CONVEX SEAT	SWIVEL 60° CONCAVE SEAT

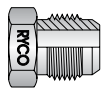

THREAD SIZE	DASH SIZE	MAX. WORKING PRESSURE			
		bar	psi	bar	psi
inch					
1/4	-04	480	7000	480	7000
3/8	-06	450	6500	450	6500
1/2	-08	350	5100	350	5100
5/8	-10				
3/4	-12				
1	-16				

METRIC DKOL (LIGHT SERIES) MALE & FEMALE O RING

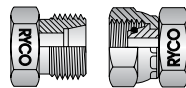

TUBE SIZE	THREAD SIZE	DASH SIZE	MAX. WORKING PRESSURE	
mm	mm		bar	psi
6	M12 x 1,5	-12	430	6300
8	M14 x 1,5	-14	430	6300
10	M16 x 1,5	-16	430	6300
12	M18 x 1,5	-18	350	5100
15	M22 x 1,5	-22	350	5100
18	M26 x 1,5	-26	350	5100
22	M30 x 2,0	-30	280	4100
28	M36 x 2,0	-36	215	3100
35	M45 x 2,0	-45	180	2600
42	M52 x 2,0	-52	180	2600

METRIC DKOS (HEAVY SERIES) MALE & FEMALE O RING

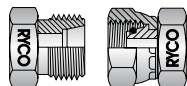

TUBE SIZE	THREAD SIZE	DASH SIZE	MAX. WORKING PRESSURE	
mm	mm		bar	psi
6	M14 x 1,5	-12	690	10000
8	M16 x 1,5	-14	690	10000
10	M18 x 1,5	-16	690	10000
12	M20 x 1,5	-20	620	9000
14	M22 x 1,5	-22	620	9000
16	M24 x 2,0	-24	420	6100
20	M30 x 2,0	-30	420	6100
25	M36 x 2,0	-36	420	6100
30	M42 x 2,0	-45	420	6100
38	M52 x 2,0	-52	420	6100

METRIC BONDED SEAL



THREAD SIZE	DASH SIZE	MAX. WORKING PRESSURE	
mm		bar	psi
M10	-10	350	5100
M12	-12	350	5100
M14	-14	350	5100
M16	-16	350	5100
M18	-18	350	5100
M20	-20	280	4100
M22	-22	280	4100
M24	-24	250	3625
M26	-26	250	3625
M27	-27	280	4100
M30	-30	215	3100
M33	-33	215	3100
M36	-36	215	3100
M42	-42	215	3100
M48	-48	215	3100

ORFS O RING FACE SEAL

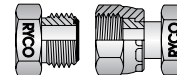

TUBE SIZE	THREAD SIZE	DASH SIZE	MAX. WORKING PRESSURE	
inch	inch		bar	psi
1/4	9/16	-09	690	10000
3/8	11/16	-11	690	10000
1/2	13/16	-13	630	9150
5/8	1	-16	630	9150
3/4	1.3/16	-19	480	7000
1	1.7/16*	-23	420	6100
1.1/4	1.11/16*	-27	280	4100
1.1/2	2*	-32	280	4100

* Wire Nut used

GUIDE TO THREAD AND CONNECTOR WORKING PRESSURES

SAE	SAE 45° FLARE	SAE INVERTED FLARE
------------	--------------------------	-------------------------------



TUBE SIZE	THREAD SIZE	DASH SIZE	MAX. WORKING PRESSURE			
			bar	psi	bar	psi
1/4	7/16	-07	690	10000	215	3100
5/16	1/2	-08	690	10000	215	3100
3/8	5/8	-10	590	8500	180	2600
7/16	11/16	-11			180	2600
1/2	3/4	-12	550	8000		
5/8	7/8	-14	520	7500		
3/4	1.1/16	-17	420	6100		
1	1.5/16	-21				
1.1/4	1.5/8	-26				
1.1/2	1.7/8	-30				
2	2.1/2	-40				

SAE FLANGE	CODE 61 SAE FLANGE	CODE 62 SAE FLANGE	RYCO CODE 62C SPECIAL FLANGE
-------------------	-------------------------------	-------------------------------	---

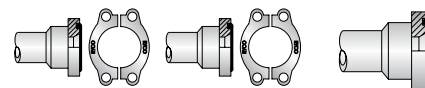

NOM. FLANGE SIZE	DASH SIZE	MAX. WORKING PRESSURE					
		bar	psi	bar	psi	bar	psi
1/2	-08	350	5100	420	6100	420	6100
5/8	-10	350	5100	420	6100	420	6100
3/4	-12	350	5100	420	6100	420	6100
1	-16	350	5100	420	6100	420	6100
1.1/4	-20	280	4100	420	6100	420	6100
1.1/2	-24	215	3100	420	6100	420	6100
2	-32	215	3100	420	6100	420	6100
2.1/2	-40	215	3100				
3	-48	140	2050				

INTRODUCTION

HOSES

TECHNICAL

RYCOLOK SUPERLOK SUPER-D	RYCOLOK MALE & FEMALE	SUPERLOK MALE & FEMALE	RYCO SUPER-D MALE & FEMALE
---	--------------------------------------	---------------------------------------	---

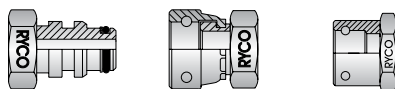

NOMINAL SIZE			MAX. WORKING PRESSURE					
DN	inch	Dash	bar	psi	bar	psi	bar	psi
6	1/4	-06	420	6100				
10	3/8	-10	420	6100				
12	1/2	-12	415	6020				
16	5/8	-16						
19	3/4	-20	350	5100	420	6100	420	6100
25	1	-25	280	4100	380	5500	420	6100
31	1.1/4	-32	215	3100	350	5100	420	6100
38	1.1/2	-40	215	3100	350	5100	420	6100
51	2	-50	170	2500	350	5100	420	6100
63	2.1/2	-63			350	5100		

WARNING: Staples must only be used ONCE, they MUST NOT BE RE-USED.
This applies to all RycoLOK, SUPERLOK and Ryco SUPER-D Staples. Failure to observe this warning may result in serious personal injury, or property damage.

TECHNICAL

GUIDE TO THREAD AND CONNECTOR WORKING PRESSURES

RYCO WEO



TUBE SIZE	DASH SIZE	MAX. WORKING PRESSURE	
		bar	psi
1/4	-04	350	5100
3/8	-06	350	5100
1/2	-08	350	5100
5/8	-10	350	5100
3/4	-12	350	5100
1	-16	250	3625

TUBE BITE

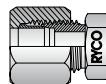

TUBE SIZE	DASH SIZE	MAX. WORKING PRESSURE	
		bar	psi
1/4	-04	260	3750
5/16	-05	260	3750
3/8	-06	260	3750
1/2	-08	220	3200
5/8	-10	220	3200
3/4	-12	220	3200
1	-16	170	2500
1.1/4	-20	140	2000
1.1/2	-24		
2	-32		

NOTE: Also consider the Maximum Working Pressure of the tubing to be used with TUBE BITE connections.

UN O RING (O RING BOSS)

UN O RING (O RING BOSS)

UN O RING (O RING BOSS) ADJUSTABLE

UN O RING (O RING BOSS) LIVE SWIVEL

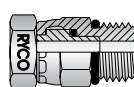

TUBE SIZE	THREAD SIZE	DASH SIZE	MAX. WORKING PRESSURE					
			bar	psi	bar	psi	bar	psi
1/4	7/16	-07	480	7000	420	6100		
5/16	1/2	-08	480	7000	420	6100		
3/8	9/16	-09	480	7000	350	5100	350	5100
1/2	3/4	-12	480	7000	350	5100	350	5100
5/8	7/8	-14	480	7000	280	4100	280	4100
3/4	1.1/16	-17	480	7000	280	4100	280	4100
7/8	1.3/16	-19	480	7000	280	4100		
1	1.5/16	-21	350	5100	280	4100		
1.1/4	1.5/8	-26	215	3100	170	2500		
1.1/2	1.7/8	-30	215	3100				
2	2.1/2	-38						

IMPORTANT NOTE REGARDING THREAD DASH SIZE/TUBE DASH SIZE

TUBE DASH SIZE - THREAD DASH SIZE

The Ryco Dash Size Part Numbering system for Connection Types associated with Inch sized tubing, follows the **THREAD** size rather than the **TUBE** size.

For example, for JIC 37° Flare; 9/16" **THREAD** is used with 3/8" OD **TUBE**.

The Ryco DASH SIZE for a JIC Hose Tail, 3/8" Hose to 3/8" Tube Size is therefore **-0609** (not -0606).

The Connection Types this applies to are as follows:

JSEAL

JIC 37°

UNO (O Ring Boss)

ORFS (O Ring Face Seal)

SAE 45°

SAE Inverted Flare

BSP, NPT, JIS, Metric DIN, and SAE Flanges are not affected.

The tables below show the relationship between **TUBE Dash Size** and **THREAD Dash Size**.

JSEAL™/JIC 37° AND UNO (O RING BOSS)

TUBE OD HOSE ID	DASH SIZE		THREAD SIZE
	TUBE/HOSE	THREAD	
1/8	-02	-05	5/16-24 UNF
3/16	-03	-06	3/8-24 UNF
1/4	-04	-07	7/16-20 UNF
5/16	-05	-08	1/2-20 UNF
3/8	-06	-09	9/16-18 UNF
1/2	-08	-12	3/4-16 UNF
5/8	-10	-14	7/8-14 UNF
3/4	-12	-17	1.1/16-12 UN
7/8	-14	-19	1.3/16-12 UN
1	-16	-21	1.5/16-12 UN
1.1/4	-20	-26	1.5/8-12 UN
1.1/2	-24	-30	1.7/8-12 UN
2	-32	-40	2.1/2-12 UN
2.1/2	-40	-48	3-12 UN

SAE 45°

TUBE OD HOSE ID	DASH SIZE		THREAD SIZE
	TUBE/HOSE	THREAD	
1/8	-02	-05	5/16-24
3/16	-03	-06	3/8-24
1/4	-04	-07	7/16-20
5/16	-05	-08	1/2-20
3/8	-06	-10	5/8-18
1/2	-08	-12	3/4-16
5/8	-10	-14	7/8-14
3/4	-12	-17	1.1/16-14

SAE INVERTED FLARE

TUBE OD HOSE ID	DASH SIZE		THREAD SIZE
	TUBE/HOSE	THREAD	
1/4	-04	-07	7/16-24
5/16	-05	-08	1/2-20
3/8	-06	-10	5/8-18
7/16	-07	-11	11/16-18

ORFS (O RING FACE SEAL)

TUBE OD HOSE ID	DASH SIZE		THREAD SIZE
	TUBE/HOSE	THREAD	
1/4	-04	-09	9/16-18 UNF
3/8	-06	-11	11/16-16 UN
1/2	-08	-13	13/16-16 UN
5/8	-10	-16	1-14 UNS
3/4	-12	-19	1.3/16-12 UN
1	-16	-23	1.7/16-12 UN
1.1/4	-20	-27	1.11/16-12 UN
1.1/2	-24	-32	2-12 UN

RYCO RYCOLOK & SUPERLOK

NOMINAL SIZE DN	INCH	DASH SIZE
10	3/8	-10
12	1/2	-12
16	5/8	-16
19	3/4	-20
25	1	-25
31	1.1/4	-32
38	1.1/2	-40
51	2	-50
63	2.1/2	-63
76	3	-75

For Ryco, RycoLOK and SUPERLOK, the Dash Size is the Nominal Size in millimetres.

INTRODUCTION
HOSES
TECHNICAL

THREAD AND CONNECTOR IDENTIFICATION

HOW TO USE THIS SECTION

This section is intended as an aid to identifying the most popular threads on hydraulic hose couplings and adaptors, and hydraulic equipment.

BSP, Metric, American and Japanese thread sizes can be very similar. It is important to measure and match every criteria of thread diameter, thread pitch, seating or sealing type (including angle of seats if present) to accurately determine thread type.

PROCEDURE

STEP 1. INVESTIGATION

Check for any markings on fitting or equipment which may be a clue to thread type. Country of origin may provide a clue.

Europe	Check DIN/BSP
UK/Australia	Check BSP
America	Check NPT/JIC/UNO/ORFS
Japan	Check JIS

All Ryco parts have a unique part number stamped on to aid identification.

STEP 2. VISUAL INSPECTION

Depending on whether the male or female thread or both are available, different features will aid identification.

- Are threads parallel or tapered?
- Is there an O Ring or a washer seal?
- If cone seats are present, are they concave or convex?
- Type and position on fittings.

STEP 3. MEASURE THREADS

With a caliper, measure the thread diameter.

- OD of male threads
- ID of female threads

Using a thread gauge, determine the number of threads per inch.

If thread gauge is not available, measure pitch from crest to crest of adjacent threads, or count the number of threads in 1/4" and multiply by four for threads per inch.

Chart at bottom of page may assist.

STEP 4. SEAT ANGLE MEASUREMENT

Using a seat gauge, determine the angle of the seat. Some fittings have dual seats (eg. JIC 37° & SAE 45°), and some have a radiused cone.

STEP 5. CONCLUSION

Match the measurements taken against those in the tables herein that appear to be similar to the coupling under consideration.

A final check can be achieved by mating with an actual coupling of the same thread.

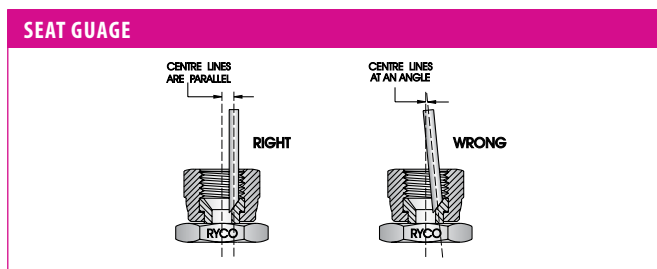
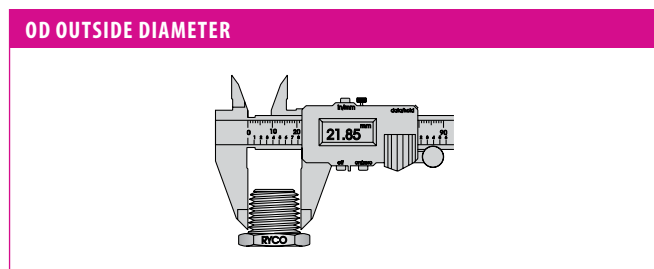
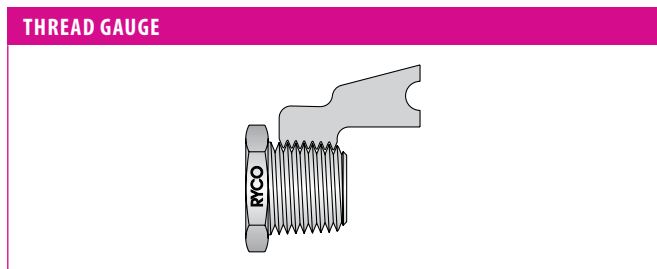
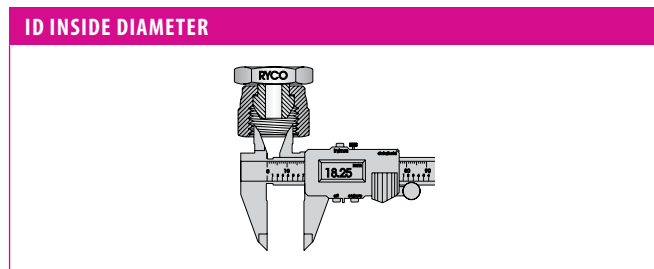

TPI (Threads Per Inch)	28	27	24	20	19	18	16	14	12	11.5	11	8	16.9	12.7
Thread PITCH (mm)	0,91	0,94	1,06	1,27	1,34	1,4	1,59	1,81	2,12	2,21	2,31	3,18	1,5	2,0

BSPT & BSPP THREADS

BSP IS BRITISH STANDARD PIPE
BSPT IS BRITISH STANDARD PIPE TAPER

ALSO KNOWN AS WHITWORTH 55° THREAD FORM
THREAD FORM PER AS 1722.1, BS 21, ISO 7-1,
DIN 3852-2 FORM C (MALE), DIN 3852-2 FORM Z (FEMALE)

BSPP IS BRITISH STANDARD PIPE PARALLEL
BSPO IS BRITISH STANDARD PIPE PARALLEL O-RING

THREAD FORM PER AS 1722.2, ISO 228 (THREAD TYPE), ISO 1179
THREAD FORM PER AS 1722.2, ISO 228 (THREAD TYPE),
ISO 8434-6, BS 5200

BSPT male threads seal against threads of fixed BSPT female. Contact is made on the flanks of the threads. Use of a thread sealant is recommended for BSPT male to BSPT female connections.

Measure the BSPT male thread OD and female thread ID at the first full thread near the end of the fitting.

BSPT male and BSPP male with conical 30° seat (60° included angle) seal against matching conical 30° seat of BSPP female swivel and BSPP female swivel with O Ring.

BSPO is BSPP O-Ring Female Swivel, and connects to BSPT male and BSPP male with conical 30° seat (60° included angle). Sealing is achieved against the matching conical 30° seat of BSPO female swivel, with the O Ring providing additional sealing capability.

BSPP O-Ring male connector has straight threads and O-Ring with metal Retaining Ring. It seals against flat external surface of BSPP female port. BSPP male, with chamfer to locate Bonded Seal also seals against flat external surface of BSPP female port.

Surface irregularities require a Spot Face to ensure effective sealing. Elbows and tees have Lock Nut to allow orientation of fitting to required direction.

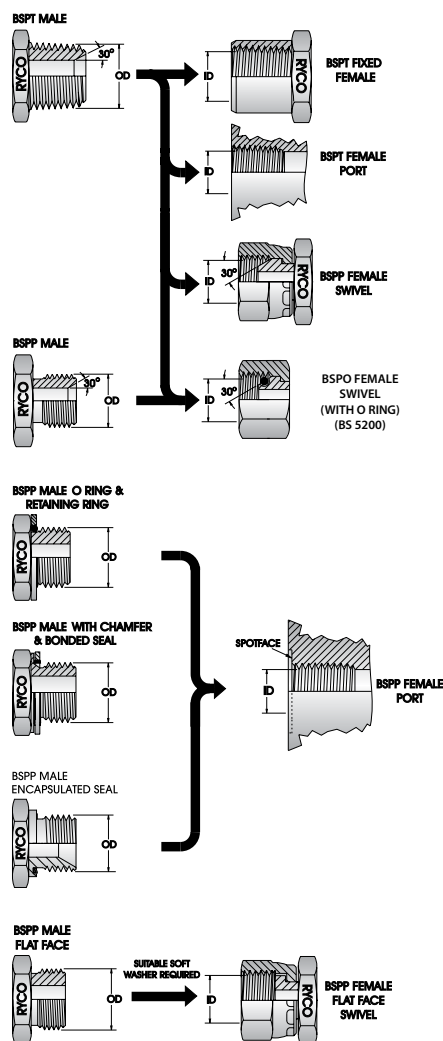

BSPP male and BSPP female flat face swivel require a suitable soft washer between faces to seal.

For low working pressure.

BSPT & BSPP THREAD DIMENSIONS

BSPT & BSPP SIZE & PITCH	DASH SIZE	BSPT MALE THREAD OD		BSPP MALE THREAD OD		BSPT FEMALE THREAD ID		BSPP FEMALE THREAD ID	
		mm	inch	mm	inch	mm	inch	mm	inch
1/8 - 28	-02	9,5	0.37	9,6	0.38	8,4	0.33	8,6	0.34
1/4 - 19	-04	12,8	0.50	13,0	0.51	11,2	0.44	11,9	0.47
3/8 - 19	-06	16,3	0.64	16,5	0.65	14,7	0.59	15,2	0.60
1/2 - 14	-08	20,4	0.80	20,8	0.82	18,3	0.72	19,1	0.75
5/8 - 14	-10	22,5	0.89	22,8	0.90	20,6	0.81	20,8	0.82
3/4 - 14	-12	25,9	1.02	26,3	1.04	23,9	0.94	24,6	0.97
1 - 11	-16	32,6	1.28	33,1	1.30	29,7	1.17	30,7	1.21
1.1/4 - 11	-20	41,1	1.62	41,8	1.64	38,6	1.52	39,4	1.55
1.1/2 - 11	-24	47,0	1.85	47,7	1.88	44,5	1.75	45,5	1.79
2 - 11	-32	58,6	2.31	59,5	2.34	56,4	2.22	57,4	2.26
2.1/2 - 11	-40	74,1	2.92	75,1	2.95	71,9	2.83	72,6	2.86
3 - 11	-48	86,6	3.41	87,9	3.46	84,6	3.33	85,4	3.36

Thread size refers to the nominal bore of the pipe. Subtract approx. 1/4" (6 mm) from thread diameter measurement for nominal pipe size. Pitch is Threads Per Inch (TPI). "Gas", "R" & "G" also refer to BSP. "Male Iron (Pipe)" may be BSP or NPT.

THREAD AND CONNECTOR IDENTIFICATION

NPT & NPS THREADS

NPT	IS	NATIONAL PIPE TAPER (AMERICAN)	THREAD FORM PER ANSI/ASME B1.20.1
NPS	IS	NATIONAL PIPE STRAIGHT (PARALLEL)	THREAD FORM PER ANSI/ASME B1.20.1
NPTF	IS	NATIONAL PIPE TAPER FOR FUEL	THREAD FORM PER SAE J476a, ANSI/ASME B1.20.3
NPSM	IS	NATIONAL PIPE STRAIGHT MECHANICAL	THREAD FORM PER ANSI/ASME B1.20.1, SAE J514

National Pipe threads are similar in function to BSP threads, but are not generally interchangeable. NPTF threads (also known as Dryseal) are an improvement to NPT. Controlled truncation of threads mean the metal-to-metal thread seal is at root and crest of threads, in addition to flanks of threads. Use of thread sealant is recommended for NPT male and NPT.

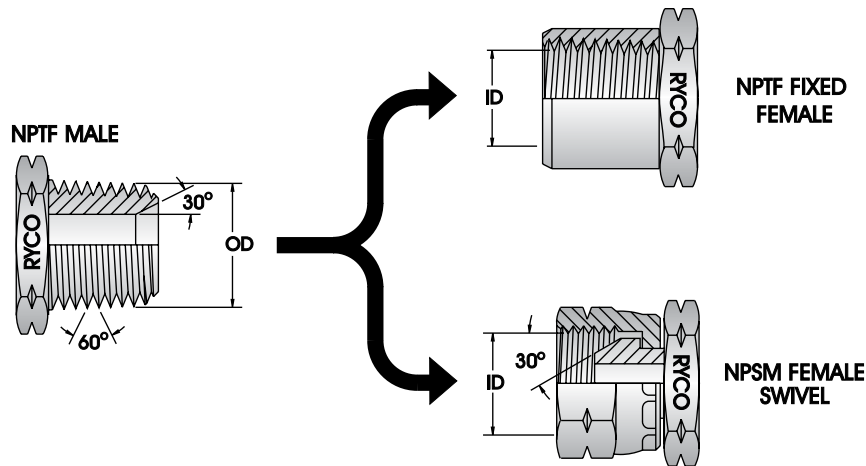

Measure NPT male thread OD and NPT female thread ID at first full thread near end of fitting.

NPT THREAD DIMENSIONS

NPT THREAD SIZE & PITCH	DASH SIZE	MALE THREAD MINOR OD		FEMALE THREAD ID	
inch - TPI		mm	inch	mm	inch
1/8 - 27	-02	9,9	0.39	8,4	0.33
1/4 - 18	-04	13,2	0.52	11,2	0.44
3/8 - 18	-06	16,6	0.65	14,7	0.58
1/2 - 14	-08	20,6	0.81	17,8	0.70
3/4 - 14	-12	26,0	1.02	23,4	0.92
1 - 11.1/2	-16	32,5	1.28	29,5	1.16
1.1/4 - 11.1/2	-20	41,2	1.62	38,1	1.50
1.1/2 - 11.1/2	-24	47,3	1.86	43,9	1.73
2 - 11.1/2	-32	59,3	2.33	56,4	2.22
2.1/2 - 8	-40	71,5	2.82	69,1	2.72
3 - 8	-48	87,3	3.44	84,8	3.34

NPSM THREAD DIMENSIONS

NPSM THREAD SIZE	DASH SIZE	FEMALE THREAD ID	
inch - TPI		mm	inch
1/8 - 27	-02	8,6	0.34
1/4 - 18	-04	11,9	0.47
3/8 - 18	-06	15,0	0.59
1/2 - 14	-08	19,1	0.75
3/4 - 14	-12	24,6	0.97
1 - 11.1/2	-16	30,5	1.20
1.1/4 - 11.1/2	-20	39,4	1.55
1.1/2 - 11.1/2	-24	45,5	1.79
2 - 11.1/2	-32	57,4	2.26
2.1/2 - 8	-40	68,8	2.71
3 - 8	-48	84,6	3.33

NOTE: Thread size refers to the nominal bore of the pipe.
 Subtract approximately 1/4" (6 mm) from thread measurement for nominal pipe size.
 Pitch is Threads Per Inch (TPI).

JSEAL™/ JIC 37° FLARE & UNO (O RING BOSS) THREADS

JSEAL™ IS	RYCO JSEAL™	PROPRIETARY CONNECTION
JIC IS	JOINT INDUSTRIES COUNCIL	SAE J514, ISO 8434-2
UN IS	UNIFIED NATIONAL	SAE J1926, ISO 11926-2
JIC & UNO (O RING BOSS) THREAD FORMS ARE THE SAME (ASME B1.1). METHOD OF SEALING DIFFERS.		

INTRODUCTION

HOSES

TECHNICAL

JSEAL™ is a Ryco proprietary connection that is fully interchangeable and backwards compatible with standard JIC connections.

With a repositioned strike zone away from the male tip, JSEAL™ design drives unrivalled performance, eliminating sweating, cracking, and stretching, while simplifying installation.

The design of JSEAL™ features a convex female seat that is engineered to be used with any JIC Male connection.

JIC male has 37° flare which seals against 37° seat in female.

JIC male can also seal against 37° flared tubing with JIC nut and sleeve.

JIC male can also be used with Ryco S134 J-Lok Female Nut and Flareless Olive on Imperial OD tubing.

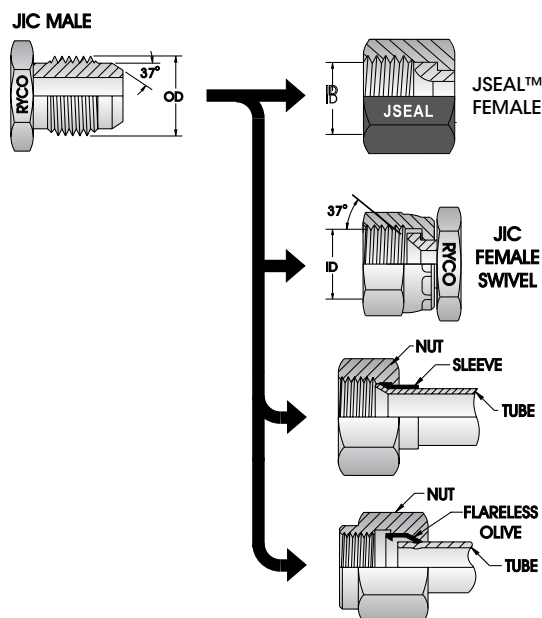

UNO (O Ring Boss) seals with O Ring compressed between hex boss of UN male and 12°/15° tapered bore of UN (O Ring Boss) female port. For elbows and tees, Back up Washer and Lock Nut allow orientation of fitting to required direction.

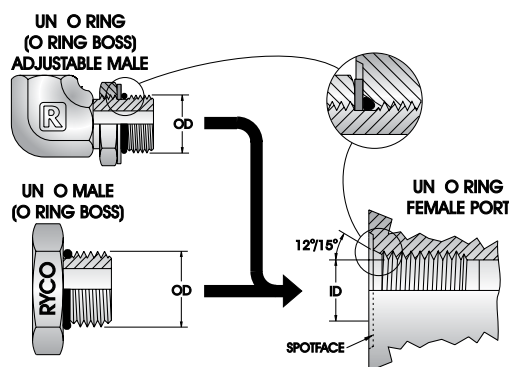

JIC & UNO THREAD DIMENSIONS

MALE THREAD OD & PITCH	DASH SIZE	MALE THREAD OD		FEMALE THREAD ID		TUBE SIZE
inch - TPI		mm	inch	mm	inch	inch
5/16 - 24 UNF	-05	7,9	0.31	6,9	0.27	1/8
3/8 - 24 UNF	-06	9,5	0.38	8,5	0.33	3/16
7/16 - 20 UNF	-07	11,1	0.44	9,9	0.39	1/4
1/2 - 20 UNF	-08	12,7	0.50	11,4	0.45	5/16
9/16 - 18 UNF	-09	14,3	0.56	13,0	0.51	3/8
3/4 - 16 UNF	-12	19,1	0.75	17,5	0.69	1/2
7/8 - 14 UNF	-14	22,2	0.88	20,3	0.80	5/8
1.1/16 - 12 UN	-17	27,0	1.06	24,9	0.98	3/4
1.3/16 - 12 UN	-19	30,2	1.19	28,2	1.11	7/8
1.5/16 - 12 UN	-21	33,3	1.31	31,2	1.23	1
1.5/8 - 12 UN	-26	41,3	1.63	39,1	1.54	1.1/4
1.7/8 - 12 UN	-30	47,6	1.88	45,5	1.79	1.1/2
2.1/2 - 12 UN	-40	63,5	2.50	61,5	2.42	2

Thread size is actual measurement of male thread and pitch is Threads Per Inch (TPI).

JIS THREADS

JIS IS JAPANESE INDUSTRIAL STANDARDS

There are four popular coupling styles in Japan.

1. JIS TAPERED PIPE THREAD.

Thread form per JIS B 0203 (identical to BSPT)

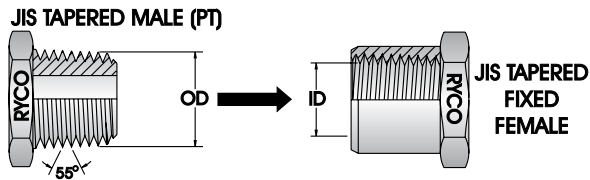

Refer to BSPT section for dimensions of threads.

- The Japanese tapered pipe thread connector is identical to and interchangeable with the BSPT (tapered) connector.
- The Japanese male thread does not have a 30° Flare, and will not mate with the BSPP female swivel with conical seat. The seal on the Japanese tapered pipe thread connector is made on the threads.
- Use of a thread sealant is recommended.

2. JIS 30° FLARE (FEMALE INTERNAL CONE SEAT).

Thread form per JIS B 0202 (identical to BSPP)

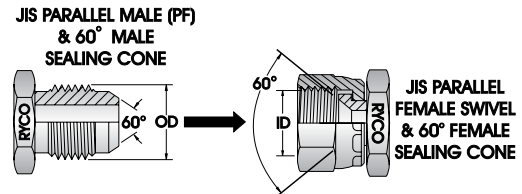

Refer to BSPP section for dimensions of threads.

- This connection uses a 60° concave (inverted) seat and British Standard Pipe Parallel threads.
- They are not interchangeable with BSPP conical seat couplings, because the cone seats are opposite.

3. JIS 30° FLARE (FEMALE INTERNAL CONE SEAT).

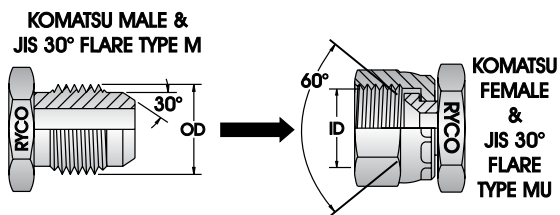

Thread form per JIS B 0207

- Threads commonly used on Komatsu equipment (30° cone) have metric thread form. See table opposite.

4. KOMATSU® STYLE FLANGE FITTING JIS B 8363

- The Komatsu® style Flange fitting is nearly identical to, and fully interchangeable with, the SAE Code 61 flange fitting*.
- The O Ring dimensions are different between all sizes.
- When replacing a Komatsu® style flange with an SAE style flange, an SAE style O Ring must always be used.
- * 5/8" is not in the SAE Standards.

MALE THREAD OD & PITCH	DASH SIZE	FEMALE THREAD ID	KOMATSU®	JIS B 8363
mm		mm		
M14 x 1,5	-14	12,5	✓	✓
M16 x 1,5	-16	14,5	✓	
M18 x 1,5	-18	16,5	✓	✓
M22 x 1,5	-22	20,5	✓	✓
M24 x 1,5	-24	22,5	✓	
M27 x 2,0	-27	25,0		✓
M30 x 1,5	-30	28,5	✓	
M33 x 1,5	-33	31,5	✓	
M33 x 2,0	-33	31,0		✓
M36 x 1,5	-36	34,5	✓	
M42 x 1,5	-42	40,5	✓	
M50 x 2,0	-50	48,0		✓
M60 x 2,0	-60	58,0		✓

BSPT & BSPP THREAD DIMENSIONS

BSPT & BSPP SIZE & PITCH	DASH SIZE	BSPT MALE THREAD OD	BSPP MALE THREAD OD	BSPT FEMALE THREAD ID	BSPP FEMALE THREAD ID
inch - TPI		mm	inch	mm	inch
1/8 - 28	-02	9,5	0.37	9,6	0.38
1/4 - 19	-04	12,8	0.50	13,0	0.51
3/8 - 19	-06	16,3	0.64	16,5	0.65
1/2 - 14	-08	20,4	0.80	20,8	0.82
5/8 - 14	-10	22,5	0.89	22,8	0.90
3/4 - 14	-12	25,9	1.02	26,3	1.04
1 - 11	-16	32,6	1.28	33,1	1.30
1.1/4 - 11	-20	41,1	1.62	41,8	1.64
1.1/2 - 11	-24	47,0	1.85	47,7	1.88
2 - 11	-32	58,6	2.31	59,5	2.34
2.1/2 - 11	-40	74,1	2.92	75,1	2.95
3 - 11	-48	86,6	3.41	87,9	3.46

Thread size refers to the nominal bore of the pipe. Subtract approx. 1/4" (6 mm) from thread diameter measurement for nominal pipe size.

Pitch is Threads Per Inch (TPI).

"Gas", "R" & "G" also refer to BSP. "Male Iron (Pipe)" may be BSP or NPT.

METRIC FRENCH GAZ ALSO KNOWN AS METRIC FRENCH GAZ 24°

These seal on a 24° cone seat located internally on the male connector using straight fine metric threads. Metric French GAZ series uses fractional number metric OD tubing, as shown in the table. Metric French Millimetric series uses whole number metric OD tubing. The two series are not interconnectable.

The male will mate with a straight thread female swivel with spherical nose seat.

The same male also mates with flareless tube, Tube Nut and Compression Olive (Cutting Ring). Tightening of the female nut compresses the olive causing it cut into the tube, thereby forming a seal between the tube, olive and 24° male cone.

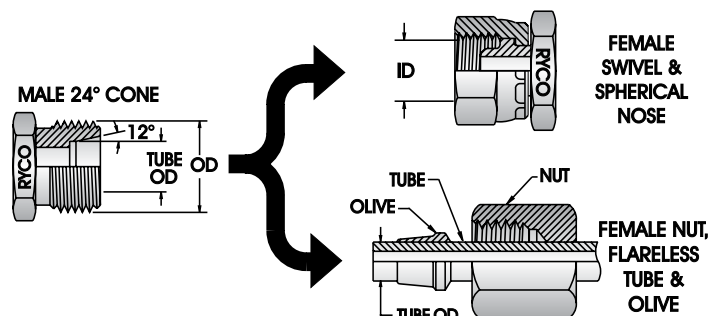

MALE THREAD OD & PITCH	DASH SIZE	MALE THREAD OD	FEMALE THREAD ID	TUBE SIZE
inch - TPI		mm	inch	mm
M20 x 1,5	-20	20,0	0.78	13,25
M24 x 1,5	-24	24,0	0.94	16,75
M30 x 1,5	-30	30,0	1.18	21,25
M36 x 1,5	-36	36,0	1.41	26,75
M45 x 1,5	-45	45,0	1.77	33,50
M52 x 1,5	-52	52,0	2.04	42,25

INTRODUCTION

HOSES

TECHNICAL

METRIC FRENCH MILLIMETRIC ALSO KNOWN AS METRIC MILLIMETRIC

These seal on a 24° cone seat located internally on the male connector using straight fine metric threads.

Metric French GAZ series uses fractional number metric OD tubing, as shown in the table.

Metric French Millimetric series uses whole number metric OD tubing. The two series are not interconnectable.

The male will mate with a straight thread female swivel with spherical nose seat.

The same male also mates with flareless tube, Tube Nut and Compression Olive (Cutting Ring). Tightening of the female nut compresses the olive causing it cut into the tube, thereby forming a seal between the tube, olive and 24° male cone.

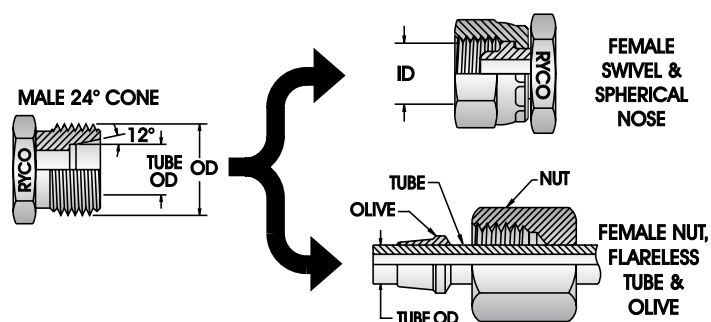

MALE THREAD OD & PITCH	DASH SIZE	MALE THREAD OD	FEMALE THREAD ID	TUBE SIZE
inch - TPI		mm	inch	mm
M27 x 1,5	-27	27,0	1.06	20
M30 x 1,5	-30	30,0	1.18	22
M33 x 1,5	-33	33,0	1.30	25
M36 x 1,5	-36	36,0	1.41	28
M39 x 1,5	-39	39,0	1.54	30
M45 x 1,5	-45	45,0	1.77	35

METRIC DIN THREADS

DIN	IS	DEUTSCHE INDUSTRIE NORMEN (GERMAN INDUSTRIAL STANDARD)	THREAD FORM PER DIN 3853, ISO 261 24° CONE SEAT PER DIN 3861, ISO 8434-1/DIN 2353 O RING SEAL PER DIN 3865, BONDED SEAL AND PORT PER DIN 3852-1
DKL	IS	DICHT KEGEL LEICHT	(METRIC LIGHT SERIES 24° CONE)
DKS	IS	DICHT KEGEL SCHWER	(METRIC HEAVY SERIES 24° CONE)
DKOL	IS	DICHT KEGEL O RING LEICHT	(METRIC LIGHT O RING SERIES 24° CONE)
DKOS	IS	DICHT KEGEL O RING SCHWER	(METRIC HEAVY O RING SERIES 24° CONE)
DKM	IS	DICHT KEGEL METRIC	(METRIC 60° CONE)

This DIN connection comes in a Light Series (DKL/DKOL) and a Heavy Series (DKS/DKOS). Some thread sizes in each series are the same, but the Tube OD of the Heavy Series is smaller and has a thicker tube wall. Because the tube and sealing cone are different sizes, Light and Heavy Series are NOT interchangeable.

The DIN male 24° internal cone seat will seal with flareless female swivel fittings. These female fittings use either a spherical nose (DKL/DKS) or an O Ring seal (DKOL/DKOS) located on their outward facing 24° cone. Female DKL sizes up to and including M26 have a universal 24°/60° cone and can be used in place of female DKM fittings with 60° cone.

The same male also mates with the DIN system Metric Tube, Tube Nut and Compression Olive (Cutting Ring). Tightening of the female nut compresses the olive causing it to cut into the tube, thereby forming a seal between the tube, olive and 24° male cone.

The same male used with a metal Bonded Seal will mate with a DIN 3852-1 metric threaded port with spotface.

DKM 60° CONE SEAT

The DIN male 60° internal cone seat will mate with DKL/DKM female universal 24°/60° cone fittings up to and including size M26 and DKM female 60° cone fittings from size M30 up.

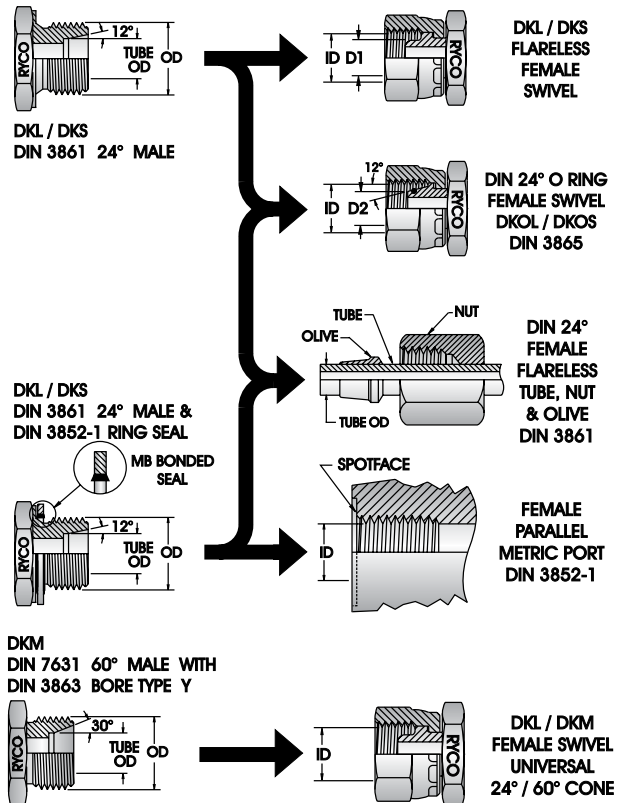

MALE THREAD OD & PITCH	FEMALE THREAD ID	DASH SIZE	LIGHT SERIES - DKL/DKOL			HEAVY SERIES - DKS/DKOS			
			TUBE OD	D1 DIA	D2 DIA	DASH SIZE	TUBE OD	D1 DIA	D2 DIA
mm	mm		mm	mm	mm		mm	mm	mm
M12 x 1,5	10,5	-1215*	6	7,5	6,3				
M14 x 1,5	12,5	-1415*	8	9,5	8,2	-1415	6	7,5	6,3
M16 x 1,5	14,5	-1615*	10	11,5	10,2	-1615	8	9,5	7,9
M18 x 1,5	16,5	-1815*	12	14,0	12,2	-1815	10	12,0	10,0
M20 x 1,5	18,5					-2015	12	14,0	12,0
M22 x 1,5	20,5	-2215*	15	17,0	15,2	-2215	14	16,0	14,2
M24 x 1,5	22,5					-2415	16	18,0	15,8
M26 x 1,5	24,5	-2615*	18	20,0	18,2				
M30 x 2,0	28,0	-3020	22	24,5	22,2	-3020	20	22,5	19,8
M36 x 2,0	34,0	-3620	28	30,5	28,2	-3620	25	27,5	24,5
M42 x 2,0	40,0					-4220	30	33,0	30,0
M45 x 2,0	43,0	-4520	35	38,0	35,4				
M52 x 2,0	50,0	-5220	42	45,0	42,4	-5220	38	41,0	36,8

*These DKL Light Series Female Connections can be used in place of DKM Female.

NOTE: in above tables, pitch is included in DASH Size.

For HOSE COUPLINGS and most ADAPTORS, pitch is not included in the DASH Size.

ORFS THREADS SAE J1453, ISO 8434-3

ORFS IS O RING FACE SEAL

ORFS system consists of ORFS Male with O Ring in Face, which seals against Flat Seated ORFS Female Swivel Nut fitting.

The Swivel Nut can be slipped back to help installation in tight situations.

The prominent position of the O Ring on the Male fitting makes it easy to inspect the condition of the O Ring.

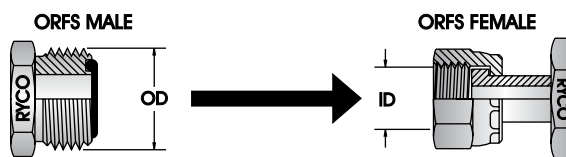

MALE THREAD OD & PITCH	DASH SIZE	MALE THREAD OD		FEMALE THREAD ID		TUBE SIZE
inch - TPI		mm	inch	mm	inch	inch
9/16 - 18 UNF	-09	14,3	0.56	12,9	0.51	1/4
11/16 - 16 UN	-11	17,3	0.68	16,0	0.63	3/8
13/16 - 16 UN	-13	20,6	0.81	19,1	0.75	1/2
1 - 14 UNS	-16	25,4	1.00	23,6	0.73	5/8
1.3/16 - 12 UN	-19	30,0	1.18	28,2	1.11	3/4
1.7/16 - 12 UN	-23	36,3	1.43	34,3	1.35	1
1.11/16 - 12 UN	-27	42,7	1.68	40,6	1.60	1.1/4
2 - 12 UN	-32	51,8	2.00	48,8	1.92	1.1/2

INTRODUCTION

HOSES

TECHNICAL

THREAD AND CONNECTOR IDENTIFICATION

SAE THREADS

SAE IS SOCIETY OF AUTOMOTIVE ENGINEERS

These fittings are commonly used in refrigeration, automotive and low pressure applications.

SAE 45° FLARE SAE J512

SAE male has 45° flare which seals against 45° seat in female.

Male can also seal against 45° flared tubing with nut and sleeve.

7/16 - 20, 1/2 - 20, 3/4 - 16 & 7/8 - 14 are the same thread form as

JIC 37° flare. Some fittings in these sizes have both JIC 37° & SAE 45° seats.

MALE THREAD OD & PITCH	DASH SIZE	MALE THREAD OD		FEMALE THREAD ID		TUBE SIZE
inch - TPI		mm	inch	mm	inch	inch
5/16 - 24	-05	7,9	0.31	6,8	0.27	1/8
3/8 - 24	-06	9,5	0.38	8,4	0.33	3/16
7/16 - 20	-07	11,1	0.44	9,9	0.39	1/4
1/2 - 20	-08	12,7	0.50	11,4	0.44	5/16
5/8 - 18	-10	15,9	0.63	14,2	0.56	3/8
3/4 - 16	-12	19,1	0.75	17,5	0.69	1/2
7/8 - 14	-14	22,2	0.88	20,6	0.81	5/8
1.1/16 - 14	-17	27,0	1.06	24,9	0.98	3/4

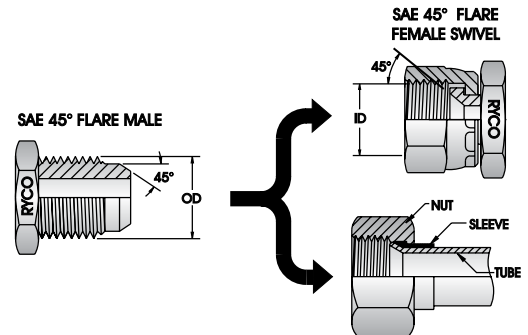

SAE 45° INVERTED FLARE

SAE J512

MALE THREAD OD & PITCH	DASH SIZE	MALE THREAD OD		FEMALE THREAD ID		TUBE SIZE
inch - TPI		mm	inch	mm	inch	inch
7/16 - 24	-07	11,1	0.44	9,9	0.39	1/4
1/2 - 20	-08	12,7	0.50	11,4	0.45	5/16
5/8 - 18	-10	15,9	0.63	14,2	0.56	3/8
11/16 - 18	-11	17,5	0.69	16,0	0.63	7/16

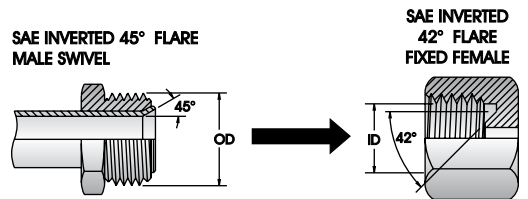

SAE PILOT O RING SEALS PILOT MALE SWIVEL

MALE THREAD OD & PITCH	DASH SIZE	MALE THREAD OD		FEMALE THREAD ID		TUBE SIZE
inch - TPI		mm	inch	mm	inch	Dash
5/8 - 18	-10	15,9	0.63	14,2	0.56	-6
3/4 - 18	-12	19,0	0.75	17,8	0.70	-8
7/8 - 18	-14	22,2	0.88	20,6	0.81	-10

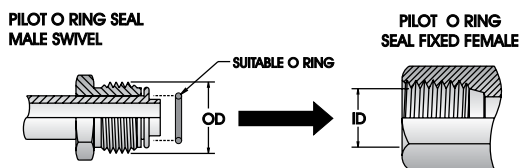

PILOT FEMALE SWIVEL

MALE THREAD OD & PITCH	DASH SIZE	MALE THREAD OD		FEMALE THREAD ID		TUBE SIZE
inch - TPI		mm	inch	mm	inch	Dash
5/8 - 18	-10	15,9	0.63	14,2	0.56	-6
3/4 - 16	-12	19,0	0.75	17,5	0.69	-8
7/8 - 14	-14	22,2	0.88	20,6	0.81	-10

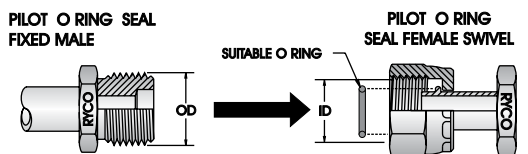

SAE O RING FLANGE - CODE 61 & CODE 62 SAE J518, ISO 6162
RYCO O RING FLANGE - CODE 62C

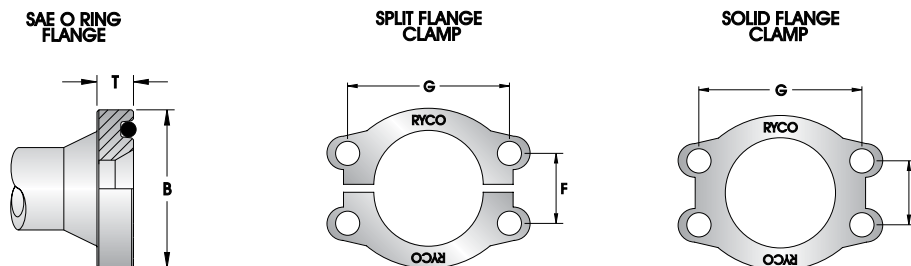

The male connector has a flange head with an O Ring groove on the face. The female can be a flange block or port with smooth face to accept the O Ring, and four threaded bolt holes in a rectangular pattern. The connection is held together using either a split or solid flange clamp, fitted over the male flange head and drawn up to the female port using the four bolts. This compresses the O Ring forming a seal between the male flange and the flat female port face.

SAE J518, DIN 20066, ISO/DIS 6162 and JIS B 8363 are all interchangeable, except for bolt sizes.

NOM. FLANGE SIZE	DASH SIZE	BØ		T		F		G		PORT THREAD & BOLT LENGTH			
		mm	inch	mm	inch	mm	inch	mm	inch	PORT	BOLT LENGTH	PORT	BOLT
inch		mm	inch	mm	inch	mm	inch	mm	inch	UNC	inch	METRIC	mm
CODE 61													
1/2	-08	30,2	1.19	6,73	0.265	17,5	0.69	38,1	1.50	5/16 - 18	1.1/4	M8 x 1,25	35
*5/8	-10	34,0	1.34	6,73	0.265	19,8	0.78	42,9	1.69	5/16 - 18	1.1/4	M8 x 1,25	35
3/4	-12	38,1	1.50	6,73	0.265	22,2	0.88	47,6	1.88	3/8 - 16	1.1/4	M10 x 1,5	35
1	-16	44,5	1.75	8,00	0.315	26,2	1.03	52,4	2.06	3/8 - 16	1.1/4	M10 x 1,5	35
1.1/4	-20	50,8	2.00	8,00	0.315	30,2	1.19	58,7	2.31	7/16 - 14	1.1/2	M10 x 1,5	40
1.1/2	-24	60,3	2.38	8,00	0.315	35,7	1.41	69,8	2.75	1/2 - 13	1.1/2	M12 x 1,75	45
2	-32	71,4	2.81	9,53	0.375	42,9	1.69	77,8	3.06	1/2 - 13	1.1/2	M12 x 1,75	45
2.1/2	-40	84,1	3.31	9,53	0.375	50,8	2.00	88,9	3.50	1/2 - 13	1.3/4	M12 x 1,75	45
3	-48	101,6	4.00	9,53	0.375	61,9	2.44	106,4	4.19	5/8 - 11	1.3/4	M16 x 2,0	45
CODE 62													
1/2	-08	31,7	1.25	7,75	0.305	18,2	0.72	40,5	1.59	5/16 - 18	1.1/4	M8 x 1,25	35
3/4	-12	41,3	1.63	8,76	0.345	23,8	0.94	50,8	2.00	3/8 - 16	1.1/2	M10 x 1,5	40
1	-16	47,6	1.88	9,53	0.375	27,8	1.09	57,2	2.25	7/16 - 14	1.3/4	M12 x 1,75	45
1.1/4	-20	54,0	2.12	10,29	0.405	31,8	1.25	66,7	2.63	1/2 - 13	1.3/4	M14 x 2,0	45
1.1/2	-24	63,5	2.50	12,57	0.495	36,5	1.44	79,4	3.13	5/8 - 11	2.1/4	M16 x 2,0	60
2	-32	79,4	3.13	12,57	0.495	44,5	1.75	96,8	3.81	3/4 - 10	2.3/4	M20 x 2,5	70
Ryco CODE 62C													
3/4	-12	41,3	1.63	14,20	0.559	23,8	0.94	50,8	2.00	3/8 - 16	1.3/4	M10 x 1,5	45
1	-16	47,6	1.88	14,20	0.559	27,8	1.09	57,2	2.25	7/16 - 14	1.3/4	M12 x 1,75	45
1.1/4	-20	54,0	2.12	14,20	0.559	31,8	1.25	66,7	2.63	1/2 - 13	2	M14 x 2,0	50
1.1/2	-24	63,5	2.5	14,20	0.559	36,5	1.44	79,4	3.13	5/8 - 11	2.1/2	M16 x 2,0	60
2	-32	79,4	3.13	14,20	0.559	44,5	1.75	96,8	3.81	3/4 - 10	2.3/4	M20 x 2,5	70

Ryco Code 62C fittings conform to the flange OD and bolt hole patterns of SAE Code 62 but require special flange clamp halves.

The Ryco Code 62C flange heads are thicker than SAE Code 62 and measure T = 14,2 mm (0.559") in all sizes.

Ryco Code 62C flanges have similar dimensions to the Caterpillar XT-5 and XT-6 range of flanges.

Cat™ Caterpillar®, XT-5™, XT-6™ Caterpillar®.

INTRODUCTION
HOSES
TECHNICAL

TECHNICAL

THREAD AND CONNECTOR IDENTIFICATION

SAE O RING FLANGE BLOCKS - CODE 61 & CODE 62 SAE J518, ISO 6162

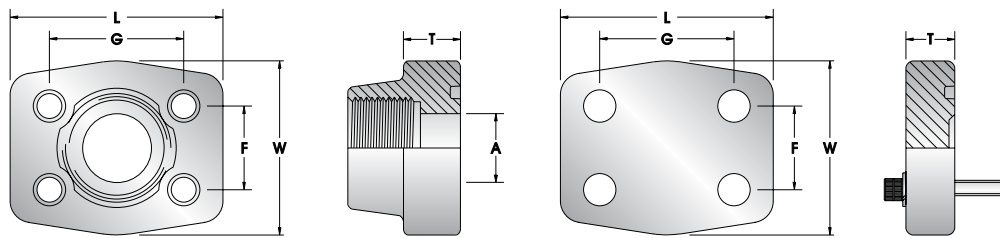

NOM. FLANGE SIZE	DASH SIZE	L		W		F		G		A		T EXCEPT BLIND FLANGES		T T BLIND FLANGES S967/S968	
		mm	inch	mm	inch	mm	inch	mm	inch	mm	inch	mm	inch	mm	inch
CODE 61															
1/2	-08	56	2.20	48	1.89	17,5	0.69	38,1	1.50	13	0.51	16	0.63	16	0.63
3/4	-12	65	2.56	50	1.97	22,2	0.88	47,6	1.88	19	0.75	18	0.71	16	0.63
1	-16	70	2.76	60	2.36	26,2	1.03	52,4	2.06	25	0.98	18	0.71	19	0.75
1.1/4	-20	79	3.11	68	2.68	30,2	1.19	58,7	2.31	32	1.26	21	0.83	18	0.71
1.1/2	-24	93	3.66	78	3.07	35,7	1.41	69,8	3.06	38	1.50	25	0.98	20	0.79
2	-32	102	4.02	90	3.54	42,9	1.69	77,8	3.50	51	2.01	25	0.98	20	0.79
CODE 62															
3/4	-12	71	2.80	60	2.36	23,8	0.94	50,8	2.00	19	0.75	21	0.83	19	0.75
1	-16	81	3.19	70	2.76	27,8	1.09	57,2	2.25	25	0.98	25	0.98	24	0.94
1.1/4	-20	95	3.74	78	3.07	31,8	1.25	66,7	2.63	32	1.26	27	1.06	27	1.06
1.1/2	-24	112	4.41	94	3.70	36,5	1.44	79,4	3.13	38	1.50	30	1.18	30	1.18
2	-32	134	5.28	114	4.49	44,5	1.75	96,8	3.81	51	2.01	37	1.46	28	1.10

NOM. FLANGE SIZE	DASH SIZE	SOCKET HEAD CAP SCREW (THREAD X LENGTH)	
		UNC x inch	METRIC x mm
CODE 61			
1/2	-08	5/16 - 18 x 1.1/4	M8x1,25 X 30
3/4	-12	3/8 - 16 x 1.1/2	M10x1,5 X 35
1	-16	3/8 - 16 x 1.1/2	M10x1,5 X 35
1.1/4	-20	7/16 - 14 x 1.3/4	M10x1,5 X 40
1.1/2	-24	1/2 - 13 x 1.3/4	M12x1,75 X 45
2	-32	1/2 - 13 x 1.3/4	M12x1,75 X 45
CODE 62			
3/4	-12	3/8 - 16 x 1.1/2	M10x1,5 X 40
1	-16	7/16 - 14 x 1.3/4	M12x1,75 X 45
1.1/4	-20	1/2 - 13 x 1.3/4	M14x2,0 X 45
1.1/2	-24	5/8 - 11 x 2	M16x2,0 X 50
2	-32	3/4 - 10 x 2.1/2	M20x2,5 X 70

RYCOLOK SAE J1467

SUPERLOK

RYCOLOK ARE ALSO CALLED CLIP FASTENER & STAPLE

The RycoLOK male connector uses an O Ring and back up washer, and seals on the smooth bore of the female. The connection is held together by the staple. The male staple groove (G) aligns with the drilled holes of the female allowing the staple to be inserted. RycoLOK and SUPERLOK use different width staples and are therefore NOT interchangeable.

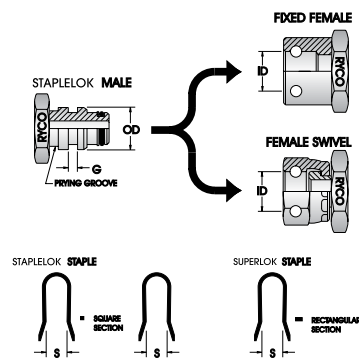

NOMINAL SIZE			NOM. MALE OD & FEMALE ID		RYCOLOK STAPLE SIZE				SUPERLOK STAPLE SIZE			
DN	inch	Dash	mm	inch	G	G	S	S	G	G	S	S
6	1/4	-06	15	0.59	5,1	0.2	8	0.31	-	-	-	-
10	3/8	-10	20	0.79	5,1	0.2	13	0.51	-	-	-	-
12	1/2	-13	24	0.94	5,1	0.2	17	0.67	-	-	-	-
16	5/8	-16	26	1.02	5,1	0.2	19	0.75	-	-	-	-
19	3/4	-20	29	1.14	5,1	0.2	22	0.87	9	0.35	22	0.87
25	1	-25	39	1.53	7,1	0.28	29	1.14	13	0.51	29	1.14
31	1.1/4	-32	46	1.81	7,1	0.28	36	1.42	13	0.51	36	1.42
38	1.1/2	-40	55	2.16	7,1	0.28	45	1.77	13	0.51	45	1.77
51	2	-50	64	2.52	7,1	0.28	54	2.13	13	0.51	54	2.13

INTRODUCTION

HOSES

TECHNICAL

RYCO WEO CARTRIDGE & CARTRIDGE PORT SPECIFICATIONS

PLUG-IN SIZE			TO SUIT RYCO WEO CARTRIDGE	A	B	C	D	E	F	G	H	J	K	L	ASSEMBLY TORQUE
DN	Dash	inch	PART No	mm	mm	mm	mm	thread	mm	mm	mm	mm	mm	mm	Nm
6	-04	1/4	RW800-04	10.03 +0.08	12.75 +0.10	16.55 +0.07	17.0 +0.1	M18x1,0	8.5 +1	1.1 -0.1	10.65 +0.1	14.15 +0.2	19.65 +0.15	0.2	25-35
10	-06	3/8	RW800-06	13.03 +0.08	16.95 +0.15	20.55 +0.07	21.0 +0.1	M22x1,0	8.7 +1	1.15 -0.1	11.1 +0.1	15.5 +0.2	21.95 +0.15	0.2	30-40
12	-08	1/2	RW800-08	16.03 +0.08	19.95 +0.15	23.55 +0.07	24.0 +0.1	M25x1,0	8.7 +1	1.25 -0.1	11.3 +0.1	15.7 +0.2	22.15 +0.15	0.3	40-50
19	-12	3/4	RW800-12	23.03 +0.08	27.95 +0.15	31.05 +0.07	31.5 +0.1	M33x1,5	11.5 +1	1.7 -0.1	16.5 +0.1	21.4 +0.2	31.35 +0.15	0.3	70-80

AVAILABLE RYCO WEO CARTRIDGE SIZES:

DN6 (1/4") RW800-04
 DN10 (3/8") RW800-06
 DN12 (1/2") RW800-08
 DN19 (3/4") RW800-12

WORKING PRESSURE:

DN6 to DN19 (1/4" to 3/4")
 350 bar (5,100 psi)

MINIMUM BURST PRESSURE:

DN6 to DN19 (1/4" to 3/4")
 1400 bar (20,400 psi)

TEMPERATURE RANGE:

-30°C to +100°C (-22°F to 212°F)

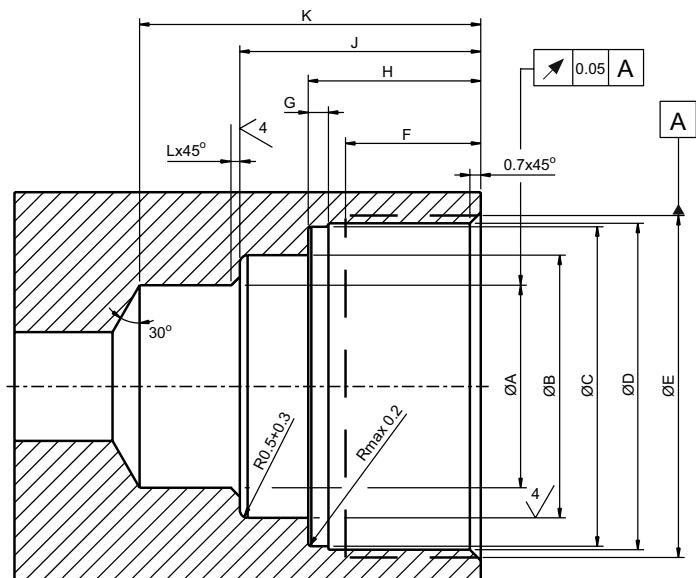

Sharp edges to be deburred 0.05-0.20 mm
 Dimension in millimeters

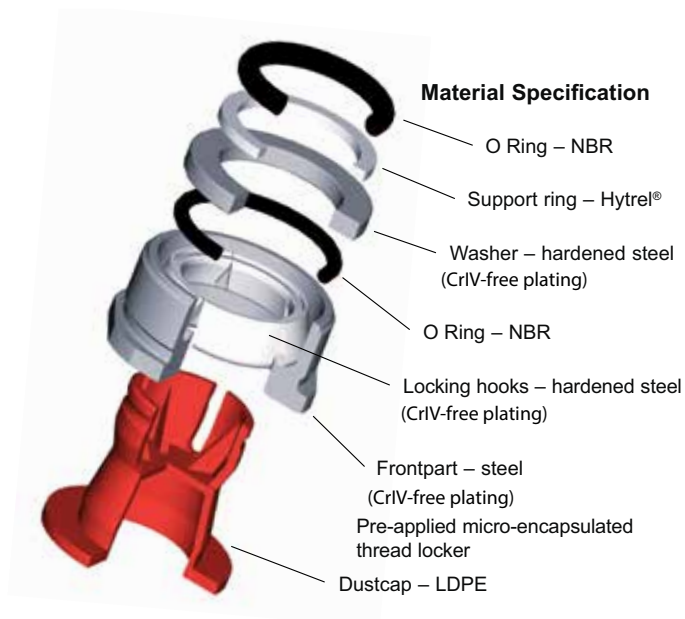

TORQUE ASSEMBLY VALUES

The Torque Values shown are for guidance only and are based on normal industrial applications. The Torque Values shown are for plated carbon steel fittings.

NM = NEWTON METRES

KG.M = KILOGRAM METRES

FT.LBF = FOOT POUNDS FORCE

TO CONVERT	» INTO »	MULTIPLY BY
Nm	ft.lbf	0.737
Nm	kg.m	0.102
ft.lbf	Nm	1.357
ft.lbf	kg.m	0.138
kg.m	Nm	9.804
kg.m	ft.lbf	7.231

INTRODUCTION

HOSES

TECHNICAL

BSPP & BSPO

BSPP SIZE	DASH SIZE	BSPP / BSPO SWIVEL NUT		BSP ENCAPSULATED SEAL SAE RECOMMENDED TORQUE RANGE		BSP BONDED SEAL			
		TORQUE RANGE		Nm	ft.lbf	RECOMMENDED TORQUE (SINGLE)		RECOMMENDED TORQUE (TANDEM SEALING)	
		Nm	ft.lbf			Nm	ft.lbf	Nm	ft.lbf
1/8	-02	11-12	8-9	35-39	26-28	25-28	18-20	40-45	29-32
1/4	-04	25-28	18-20	60-66	44-49	51-55	37-40	67-72	49-52
3/8	-06	41-48	30-35	95-105	70-77	80-89	59-65	104-116	77-85
1/2	-08	72-82	55-60	130-143	96-105	99-105	73-77	119-126	88-93
5/8	-10	96-110	70-80	180-198	133-146	136-146	100-107	150-161	110-118
3/4	-12	124-137	90-100	200-220	147-162	220-230	162-169	242-253	179-186
1	-16	151-165	110-120	450-495	332-365	371-407	273-300	409-448	301-330
1.1/4	-20	192-206	140-150	500-550	369-405	501-510	369-376	527-536	388-395
1.1/2	-24	261-275	190-200	600-660	442-486	601-611	443-450	632-642	466-473
2	-32	343-357	250-260	700-770	516-567	746-756	550-557	784-794	578-585

*2" (-32) sizes of BSP Encapsulated Seal use an O-Ring seal.

METRIC

THREAD SIZE	24°, 60° & UNIVERSAL INVERTED CONE				BONDED SEAL					
	TUBE DIA. S-HEAVY mm	TUBE DIA. L-LIGHT mm	SWIVEL NUT TORQUE RANGE		THREAD SIZE	DASH SIZE	RECOMMENDED TORQUE (SINGLE)		RECOMMENDED TORQUE (TANDEM SEALING)	
			Nm	ft.lbf			Nm	ft.lbf	Nm	ft.lbf
M12 x 1,5		6	10-20	7-15	M10	-10	53-59	39-43	85-95	63-69
M14 x 1,5	6	8	20-35	15-26	M12	-12	55-60	40-44	88-96	64-71
M16 x 1,5	8	10	25-40	18-30	M14	-14	72-79	53-58	101-111	75-82
M18 x 1,5	10	12	30-45	22-33	M16	-16	80-89	59-65	104-116	77-85
M20 x 1,5	12		35-50	26-37	M18	-18	82-90	60-66	107-117	78-86
M22 x 1,5	14	15	40-70	30-52	M20	-20	99-109	73-80	119-131	88-96
M24 x 1,5	16		40-70	30-52	M22	-22	136-150	100-110	157-173	115-127
M26 x 1,5		18	60-100	44-74	M24	-24	147-162	108-119	170-187	125-137
M30 x 2,0	20	22	80-120	59-89	M26	-26	171-182	126-134	189-201	139-148
M36 x 2,0	25	28	100-150	74-111	M27	-27	220-235	162-173	242-259	179-191
M42 x 2,0	30		150-220	111-163	M30	-30	270-287	199-211	297-316	219-233
M45 x 2,0		35	180-250	133-184	M33	-33	371-392	273-289	409-432	301-318
M52 x 2,0	38	42	200-300	148-221	M36	-36	390-398	287-293	429-438	316-323
					M42	-42	405-413	298-304	446-455	328-335
					M48	-48	501-510	369-376	552-561	406-414

TECHNICAL

TORQUE ASSEMBLY VALUES

JSEAL™

JSEAL™ THREAD SIZE	DASH SIZE	SAE RECOMMENDED NUT TORQUE VALUE	
		Nm	ft.lbf
7/16 - 20	-07	23	17
1/2 - 20	-08	30	22
9/16 - 18	-09	39	29
3/4 - 16	-12	77	57
7/8 - 14	-14	142	105
1.1/16 - 12	-17	198	146
1.3/16 - 12	-19	235	173
1.5/16 - 12	-21	263	194
1.5/8 - 12	-26	309	228
1.7/8 - 12	-30	386	285
2.1/2 - 12	-40	597	440

JIC 37° & SAE 45° (MACHINED OR FLARED)

JIC/SAE THREAD SIZE	DASH SIZE	SAE RECOMMENDED SWIVEL NUT TORQUE RANGE	
		Nm	ft.lbf
5/16 - 24	-05	8-9	6-7
3/8 - 24	-06	11-12	8-9
7/16 - 20	-07	15-16	11-12
1/2 - 20	-08	19-21	14-15
9/16 - 18	-09	24-28	18-20
3/4 - 16	-12	49-53	36-39
7/8 - 14	-14	77-85	57-63
1.1/16 - 12	-17	107-119	79-88
1.3/16 - 12	-19	127-140	94-103
1.5/16 - 12	-21	147-154	108-113
1.5/8 - 12	-26	172-181	127-133
1.7/8 - 12	-30	215-226	158-167
2.1/2 - 12	-40	332-350	245-258

SAE FLANGE CLAMP BOLTS CODE 61 & 62

BOLT DATA UN CLASS 2A (THREAD X LENGTH)	FLANGE DASH SIZE	SAE RECOMMENDED BOLT TORQUE RANGE	
		Nm	ft.lbf
CODE 61			
5/16 - 18 X 1.1/4	-08	20-25	15-18
3/8 - 16 X 1.1/4	-12	28-40	21-29
3/8 - 16 X 1.1/4	-16	37-48	27-35
7/16 - 14 X 1.1/2	-20	48-62	35-46
1/2 - 13 X 1.1/2	-24	62-79	46-58
1/2 - 13 X 1.1/2	-32	73-90	54-66
1/2 - 13 X 1.3/4	-40	107-124	79-91
5/8 - 11 x 1.3/4	-48	186-203	138-150

CODE 62			
5/16 - 18 X 1.1/4	-08	20-25	15-18
3/8 - 16 X 1.1/2	-12	34-45	25-33
7/16 - 14 X 1.3/4	-16	56-68	41-50
1/2 - 13 X 1.3/4	-20	85-102	63-75
5/8 - 11 X 2.1/4	-24	158-181	116-133
3/4 - 10 X 2.3/4	-32	271-294	200-217

UNO (O RING BOSS)

UNO THREAD SIZE	DASH SIZE	SAE RECOMMENDED STRAIGHT FITTING OR LOCK NUT TORQUE RANGE	
		Nm	ft.lbf
3/8 - 24	-06	11-13	8-10
7/16 - 20	-07	20-22	14-16
1/2 - 20	-08	24-27	18-20
9/16 - 18	-09	33-35	24-26
3/4 - 16	-12	68-78	50-60
7/8 - 14	-14	98-110	72-82
1.1/16 - 12	-17	170-183	125-135
1.3/16 - 12	-19	230-260	170-190
1.5/16 - 12	-21	270-300	200-220
1.5/8 - 12	-26	285-380	210-280
1.7/8 - 12	-30	370-490	270-360

ORFS

ORFS THREAD SIZE	DASH SIZE	SAE RECOMMENDED SWIVEL NUT TORQUE RANGE	
		Nm	ft.lbf
9/16 - 18	-09	14-16	10-12
11/16 - 16	-11	24-27	18-20
13/16 - 16	-13	43-47	32-35
1 - 14	-16	60-68	46-50
1.3/16 - 12	-19	90-95	65-70
1.7/16 - 12	-23	125-135	92-100
1.11/16 - 12	-27	170-190	125-140
2-12	-32	200-225	150-165

SAE FLANGE BLOCK BOLTS CODE 61 & 62

BOLT DATA UN CLASS 2B (THREAD X LENGTH)	FLANGE DASH SIZE	RECOMMENDED BOLT TORQUE RANGE	
		Nm	ft.lbf
CODE 61			
5/16 - 18 X 1.1/4	-08	20-25	15-18
3/8 - 16 X 1.1/2	-12	28-40	21-29
3/8 - 16 X 1.1/2	-16	37-48	27-35
7/16 - 14 X 1.3/4	-20	48-62	35-46
1/2 - 13 X 1.3/4	-24	62-79	46-58
1/2 - 13 X 1.3/4	-32	73-90	54-66

CODE 62			
3/8 - 16 X 1.1/2	-12	34-45	25-33
7/16 - 14 X 1.3/4	-16	56-68	41-50
1/2 - 13 X 1.3/4	-20	85-102	63-75
5/8 - 11 X 2	-24	158-187	116-138
3/4 - 10 X 2.1/2	-32	271-294	200-217

AF	Across Flats	EXT	Extended	NB	Nominal Bore
ABS, Abs.	Absolute	F, FEM	Female	NCB	National Coal Board
ABS	American Bureau of Shipping	FF	Female Fixed	NCS	NATA Certification Services
AC	Air Conditioning	FIX	Fixed	NFPA	National Fluid Power Association (USA)
AGA	Australian Gas Association	FLNG	Flange	Nm	Newton Metre
API	American Petroleum Institute	FOS	Factor Of Safety	NOM, Nom.	Nominal
AS	Australian Standard	FS	Female Swivel	NPS	National Pipe Straight Thread
AV	Average	ft	Foot	NPSM	National Pipe Straight Mechanical
BCS	British Coal Standard	ft.lbf	Foot Pound force	NPSMFS	National Pipe Straight Mechanical Female Swivel
BH	Bulkhead	g	Gram	NPT	National Pipe Taper Thread
BP	Burst Pressure	GL	Germanischer Lloyd	NPTF	National Pipe Taper for Fuel
BS	British Standard	GPM	Gallons Per Minute	NPTFF	National Pipe Taper Female Fixed
BSP	British Standard Pipe	HM	Hexagon, Male	NPTM	National Pipe Taper Male
BSPP	British Standard Pipe Parallel Thread	HF	Hexagon, Female	OA, O/A	Overall
BSPPFS	British Standard Pipe Parallel Female Swivel	HP	High Pressure	OD	Outside Diameter
BSPPMBH	British Standard Pipe Parallel Male Bulkhead	hp	Horse Power	ORFS	O Ring Face Seal
BSPO	BSPP O Ring Female Swivel	HTS	High Tensile Steel	ORFSFS	ORFS Female Swivel
BSPPOM	British Standard Pipe Parallel O Ring Male	HW	Heavy Wall	ORFSM	ORFS Male
BSPPOM EXT	British Standard Pipe Parallel O Ring Male Extended	ID	Inside Diameter	PCD	Pitch Circle Diameter
BSPT	British Standard Pipe Taper Thread	inHg	Inches of Mercury	PCV	Positive Crankcase Ventilation
BSPTFF	British Standard Pipe Taper Female Fixed	IMP	Imperial	P/N, P/NO	Part Number
BSPTM	British Standard Pipe Taper Male	INV	Inverted	PREV	Previous
BSW	British Standard Whitworth	ISO	International Organization for Standardization	psi	Pounds per Square Inch
C/W	Complete With	JIC	Joint Industries Council (Thread UN)	PTFE	Polytetrafluoroethylene
CA	Cut-off Allowance	JICFS	JIC Female Swivel	PW	Pressure Washer
CAT	Caterpillar®	JICM	JIC Male	QA	Quality Assurance
CL, C/L	Cut Length	JICMBH	JIC Male Bulkhead	QC	Quality Control
CrVI	Chromium 6	JICMEXT	JIC Male Extended	QRC	Quick Release Coupling
cSt	Centistoke	JIS	Japanese Industrial Standard	RED	Reducing
DIA, DIAM	Diameter	kg	Kilogram	RMA	Rubber Manufacturers Association
DIN	Deutsche Industrie Normen (German Industrial Standard)	kg.m	Kilogram Metres	RPM	Revolutions Per Minute
DKL	Dicht Kegel Leicht (Metric Light Series 24° Cone)	kPa	KiloPascal	RQP	Ryco Quality Product
DKM	Dicht Kegel Metric (Metric 60° Cone)	kW	Kilowatt	SAE	Society of Automotive Engineers (USA)
DKO	Dicht Kegel O Ring (Metric O Ring Seal 24° Cone)	LNG	Long	SAEFS	SAE Female Swivel
DKOL	Dicht Kegel O Ring Leicht (Metric Light O Ring Series 24° Cone)	L	Litre	SAEM	SAE Male
DKOS	Dicht Kegel O Ring Schwer (Metric Heavy O Ring Series 24° Cone)	L	Length (Couplings Section)	SF	Swivel Female (Union)
DKS	Dicht Kegel Schwer (Metric Heavy Series 24° Cone)	lb	Pound	SS	Stainless Steel
DL	Drop Length	LP	Low Pressure	STD	Standard
DN	Diameter Nominal (mm)	LPG	Liquified Petroleum Gas	STPL	Staple
DNV	Det Norske Veritas	LPM	Litres Per Minute	SWIV	Swivel
DoT	Department of Transportation (USA)	LR	Lloyd's Register	T/NESS	Thickness
EEC	Evaporative Emission Control	M	Male	TBA	To Be Advised
ELB	Elbow	m	Metre	THRD	Thread
EPDM	Ethylene Propylene Diene Monomer	MAX	Maximum	TP	Test Pressure
		MBP	Minimum Burst Pressure	TPI	Threads Per Inch
		MED	Marine Equipment Directive	TW	Tube Weld
		MFL	Minimum Free Length	UN	Unified National Thread
		MIC, Mic.	Micron (µm)	UNO	UN O Ring (O Ring Boss)
		MIL	Military Specification (USA)	UNOM	UNO Male (O Ring Boss Male)
		MIN	Minimum	UNOMEXT	UNO Male Extended (O Ring Boss Male Extended)
		mm	Millimetre	USCG	United States Coast Guard
		mmHg	Millimetres of Mercury	WP	Working Pressure
		MPa	MegaPascal	°C	Degrees Celcius
		MSHA	USA Department of Labor, Mine Safety and Health Administration.	°F	Degrees Fahrenheit
		MWP	Maximum Working Pressure	β	Beta (filtration)
		NA, N/A	Not Applicable	mm	Micron
		NAHAD	National Association of Hose and Accessories Distributors (USA)		
		NATA	National Association of Testing Authorities (Aus.)		

T3000D	24	SRF/P	87
T3000D	24	SRX/HT	88
T3000D	24	RTH1	89
T3000S	25	PL1D	90
T3000S	25	PL1PV	91
T3600C	26	MP1	92
T3600D	27	TP7	95
T3600S	28	TP7N	96
T4000D	29	TP7T	97
T4000S	30	TP7TN	98
T5000D	31	TP8	99
T5000S	32	TP8N	100
T6000D	33	TP8T	101
T6000S	34	TP8TN	102
H3000D	35	TP3000	103
H3000S	36	TPGL	104
H4000D	37	R4100N	105
H4000S	38	FS1072	107
H5000C	39	RCS	110
H5000D	40	RH	113
H5000S	41	RSG	114
H6000D	42	RSG	115
H6000S	43	RWA	116
C6000D	44	RWA	117
C6000S	45	RHYS	118
DF1D	46	750/760	119
DF2D	47	RHYT/RHWT	120
DK1D	48	HOSE SIZE SELECTION NOMOGRAPH	123
DK1E	49	HOW TO ORDER HOSE ASSEMBLIES	124
DK1S	50	HOSE SELECTION	126
DK2D	51	SAFETY GUIDE	128
DK2E	52	SAFETY GUIDE – MAXIMUM TEMPERATURE LIMITS	131
DK2S	53	SAFETY GUIDE – MAXIMUM TEMPERATURE LIMITS	132
EC1 & EC2	54	CHARACTERISTICS OF HOSE ELASTOMERS	133
E1 & E2	54	CHEMICAL COMPATIBILITY FOR HOSE	134
EC1	55	FIELD ATTACHABLE NON-SKIVE HOSE ASSEMBLY	135
EC2	56	NON-SKIVE HOSE ASSEMBLY	137
ECP1 PILOT	57	SKIVE HOSE ASSEMBLY	138
E1	58	ASS. INSTRUCTIONS – RTH1 HOSES	139
E2	59	ASS. INSTRUCTIONS – SRX/HT & SRF/P HOSES	140
T1D	60	PUSH-ON HOSE ASSEMBLY	141
T1S	61	ASS. INSTRUCTIONS – TP7T, TP7TN, TP8T AND TP8TN TWIN HOSE	142
T1F	62	TUBE FLARING DIMENSIONS – 37° JIC AND 45° SAE	143
T2D	63	TUBE FLARING DIMENSIONS – 37° JIC AND 45° SAE	144
T2S	64	ASS.Y INSTRUCTIONS – TUBE BITE HOSE COUPLINGS (END STYLE 850)	145
T2C	65	ASS. INSTRUCTIONS – S134 J-LOK FLARELESS TUBE FITTINGS	147
TXA2D	66	ASS. INSTRUCTIONS – S134 J-LOK FLARELESS TUBE FITTINGS	148
H12D	67	HOSE ASS. – INSTALLATION GUIDE	149
H12S	68	FACTOR OF SAFETY - HOSE ASSEMBLIES	152
TJ2D	70	GUIDE TO THREAD AND CONNECTOR WORKING PRESSURES	153
D4000D	72	IMPORTANT NOTE REGARDING THREAD DASH SIZE/TUBE DASH SIZE	158
SURVIVOR/1	73	THREAD AND CONNECTOR IDENTIFICATION	159
SURVIVOR/2	74	TORQUE ASSEMBLY VALUES	172
SURVIVOR/R5	75	ABBREVIATIONS	174
D2B	76		
T5	77		
MS1000	78		
CS1000	79		
BT1	81		
SW	82		
JS4000/G	83		
JS4000BX/GX	84		
JS6000/G	85		
JS6000BX/GX	86		

RYCO[®]

www.ryco-hydraulics.com



SCAN HERE FOR MORE
CONTACT INFORMATION